



**Journey**

# TABLE OF CONTENTS

Warranty and Safety Guidelines.....	Pages 3-10
Leveling the play set, General Information and Definitions.....	Pages 10-13
Site Plan, Tool List and Kit Contents.....	Pages 14-15
Hardware, Lumber and Accessory Checklist.....	Pages 16-24
Adding T-Nuts to Corner Posts and Deck Supports.....	Steps 1-5
Framing Play Set.....	Steps 6-9
Installing Picnic Table Supports and Legs.....	Steps 10-13
Leveling the Side Frame Assemblies.....	Step 13A
Front - Rear Panel Boards and Deck Spacers.....	Step 14
Diagonal Brace.....	Step 15
Attaching Deck Panel Boards and Rock Wall Boards.....	Steps 16-17
Picnic Table/Seat Boards and Deck Boards.....	Steps 18-19
Panel Slats, Tarp Boards and Tarp.....	Steps 20-23
Swing Beam Assembly and <b>Play Set Placement ! IMPORTANT !</b> .....	Steps 24-31
Attaching Wave Slide.....	Step 32
Attaching Telescope.....	Step 33
Attaching Safety Handles.....	Step 34
Attaching Flags.....	Step 35
Installing Ground Stakes.....	Steps 36
Hanging Swings and Installing Rocks.....	Steps 37-38
Attaching PlayNation Logo Plate.....	Step 39
Warranty Registration Card.....	Last Page

**PLEASE READ OWNER'S MANUAL CAREFULLY  
BEFORE STARTING ASSEMBLY!**

## **IMPORTANT – PLEASE READ**

As fresh lumber acclimates to its new environment, the natural tendencies of the tree can show itself in the form of checks, or “cracks” in the lumber. In almost all cases this is normal and it will not affect the structural integrity of your play set.

Cosmetic defects that do not affect the structural integrity of the product, or natural defects of wood such as warping, checking or any other physical properties of wood that do not present a safety hazard, are not covered by this warranty. Defects that develop because the product is exposed to extreme climate conditions are not covered by this warranty. Defects that develop as a result of faulty or improper installation of the product are also not covered by this warranty.

Most cracks are not warrantable, however if you believe that the integrity of your play set is compromised by this natural occurrence, please follow the warranty claim procedure found at

Click on the “Customer Care” tab on the left hand side of the page, then click on “Warranty Claim” and follow the instructions.

We appreciate your purchase and know that you will enjoy your play system for many years to come.

# **Thank you for choosing Gorilla Playsets®**

We've included everything you need, except tools, to build your very own professional looking play set. When complete, your new play set should far exceed the quality of play set kits from other build-your-own companies. Our engineers and design team have over 30 years of playground experience. What we've developed is a play set that doesn't compromise quality for simplicity. Yet you'll appreciate how quick and easy construction really is! Our play set kits are designed for children ages 3 to 11. Y ^ believes every child should have a play set and with our kits they can! You can rest assured your new play set is safe, durable and designed to hold up to the elements. As parents ourselves, we know how important the security and well-being of our children is, and this shows in all of our products.

Each play set features our step-by-step 3D illustrated manual, patented powder coated swing beam bracket, heavy-duty swing belts with chains, slide(s), accessories, plus all the required hardware and pre-milled lumber.

## **Quality Lumber**

Y ^ use only the finest, hand selected lumber available. You can be assured that our lumber is strong, durable, and conforms to the national standards for use in children's play equipment. It's this quality that allows us to offer a 10 year warranty on the lumber used in our play sets.

# Limited Manufacturers Warranty

Y ^Á arrants its play sets to be free from defects in workmanship and materials, under normal use and conditions at its original installation, for 10 years for structural wood components and for one year for all other components (e.g., hardware, plastics, tarps, rope ladder, etc.)

Cosmetic defects or natural defects of wood (e.g., warping, seasonal checking or cracking, knots, or knot holes, etc.) that do not affect the structural integrity of the product are not covered by this warranty. Defects that develop because the product is exposed to extreme climate conditions, or that develop as a result of faulty or improper installation of the product, are not covered by this warranty. Fading or discoloration of any part or accessory, cracks in plastic components, surface rust on hardware, and chips on powder coated materials are not considered defects in material as long as they do not affect the functionality or structural integrity of the part or component.

It is the owner's responsibility to properly maintain the play set. Instructions for proper maintenance can be found on @ website. Imperfections or defects that develop because of a failure to properly maintain the play set are not covered by this warranty.

Gorilla will repair or, at its discretion, replace any part within the stated warranty period that is defective in workmanship or materials. This decision is subject to verification of the defect, which, at Gorilla's discretion, may be accomplished by submitting photographs or by delivery of the defective part to Gorilla. Any warranty claim must include proof of purchase, including the date of purchase.

This warranty is valid only if the product is used for the purpose for which it was d signed and installed at a residential, single-family dwelling. This warranty is void if the product is put to commercial or institutional use. This warranty does not cover (a) products that have been damaged by acts of God, negligence, misuse, or accident, or that have been modified or repaired by unauthorized persons; (b) the cost of labor; or (c) the cost of shipping the product, any part, or any replacement product or part.

GORILLA DISCLAIMS ALL OTHER REPRESENTATIONS AND WARRANTIES OF ANY KIND, EXPRESSED, IMPLIED, STATUTORY, OR OTHERWISE, INCLUDING THE IMPLIED WARRANTIES OF MERCHANTABILITY AND FITNESS FOR A PARTICULAR PURPOSE. GORILLA WILL NOT BE LIABLE FOR ANY INCIDENTAL OR CONSEQUENTIAL DAMAGES. This warranty is valid only in the United States of America, is nontransferable and does not extend to the owners of the product subsequent to the original purchaser, and only applies to the product as originally installed (in other words, installing the product and then later disassembling and reinstalling the product at the same or another location voids the warranty). Some states do not allow limitations on implied warranties or exclusion of incidental or consequential damages, so these restrictions may not be applicable to you. This warranty gives you specific legal rights. You may also have other rights which vary from state to state.

# IMPORTANT SAFETY GUIDELINES

This product is intended for residential use only and not intended for use in any public setting. A safety surface such as mulch or recycled tire should be used under the play set to prevent injury from falls. Also a 6 foot safety zone should be used around the entire play set.

As with any home project, good judgment and respect for power tools will greatly reduce the risk of injury. Gorilla recommends you follow all tool manufacturers' safety guidelines. Always wear eye protection and safety gloves to prevent injury. In several phases of construction two people may be required for lifting and securing of lumber. While play set is being constructed, please keep children off the equipment until the project is complete. Bolts and screw heads should be checked regularly for tightness. The ground ladder, rope ladder, slide, swings and other areas where children spend a majority of their playtime should be checked more frequently.

Gorilla shall not be liable for incidental, indirect or consequential damages or injuries that result from the building and/or playing on our play sets. Adult supervision is recommended anytime a play set is being used.

## WEIGHT LIMITS FOR PLAYSETS

- FORT PLATFORM: 250 LBS. TOTAL WEIGHT
- SWING BELTS: 275 LBS.
- GLIDER SWINGS: 70 LBS. PER CHILD
- TRAPEZE: 125 LBS.
- FULL BUCKET SWING: 85 LBS.
- TODDLER HALF BUCKET SWING: 85 LBS.
- INFANT SWING: 35 LBS.
- TIRE SWING: 125 LBS. TOTAL WEIGHT
- ROPE LADDER: 75 LBS.
- ROCK WALL: 150 LBS.
- ALL SLIDES: 125 LBS.

Gorilla recommends that the weight limits for all components must not be exceeded. Failure to adhere to these and other safety guidelines could result in damage to the play set and injury to the users.

# **Safety and Maintenance Tips for Your New Play Set:**

**NOTE: Your children's safety is our #1 concern. Observing the following statements and warnings reduces the likelihood of serious or fatal injury. Please review these safety rules regularly with your children.**

- This play set is designed for the use of 2 occupants who have a combined weight not exceeding 250 pounds on the elevated floor, 3 occupants who have a combined weight of 400 pounds on the swing area, for a total Unit capacity of 5 occupants who have a combined weight of 650 pounds. (this weight is not including the picnic table area)
- On-site adult supervision is required.
- Teach children not to walk close to, in front of, behind, or between moving swings or other moving playground equipment.
- Teach children to sit in and never stand on swings
- Teach children not to twist the chains and ropes and not to loop them over the swing beam, since this may reduce the strength of the chain or rope.
- Teach children not to jump from swings or other playground equipment in motion.
- Teach children not to push empty seats. The seat may hit them and cause serious injury.
- Teach children to sit in the center of the swings with their full weight on the seats.
- Teach children not to use the equipment in a manner other than intended.
- Teach children to always go down slides feet first. Never slide headfirst.
- Teach children to look before they slide to make sure no one is at the bottom.
- Teach children to never run up a slide, as this increases their chances of falling.
- The parents should have the children dress appropriately with well-fitting shoes. Loose clothing such as scarves and ponchos should not be worn. Always take off, tie up or tuck in cords and drawstrings on children's clothing. These things can get caught on playground equipment and strangle a child.
- Teach children not to climb when the equipment is wet.
- Teach children to never jump from a fort deck. They should always use the ladder, ramp or slide.
- Teach children to never crawl or walk across the top of monkey bars.
- Teach children to never crawl on top of a fort roof.
- Verify that any suspended climbing ropes, chains, or cables are secured at both ends and that they cannot be looped around an adult hand.
- Teach children not to attach items to the playground equipment that are not specifically designed for use with the equipment, such as, but not limited to, jump ropes, clothesline, pet leashes, cables and chain as they may cause a strangulation hazard.
- Teach children to never wrap their legs around swing chain.
- Teach children to never slide down the swing chain.

**WARNING: Children must NOT use this play set until unit has been completely assembled and inspected by an adult to insure set has been properly installed and anchored.**

# **Safety and Maintenance Tips for Your New Play Set: (continued)**

Playgrounds should be inspected on a regular basis. If any of the following conditions are noted, they should be removed, corrected, or repaired immediately to prevent injuries.

- Hardware that is loose, worn or that has protrusions or projections
  - Exposed equipment footings
  - Scattered debris, litter, rocks, or tree roots
  - Splinters, large cracks, and decayed wood components.
  - Deterioration and corrosion on structural components, which connect to the ground
  - Missing or damaged equipment components, such as handholds, guardrails, swing seats.
  - Check all nuts and bolts frequently during the usage season and tighten as required. (But not so tight that you crack the wood) We recommend you check the swing beam and hardware often due to wood expansion and contraction. It is particularly important that this procedure be followed at the beginning of each season.
  - Remove plastic swing seats and take indoors or do not use when the temperature drops below 32°F.
  - Oil all metallic moving parts monthly during the usage period.
  - Check all coverings for bolts and sharp edges twice monthly during usage season to be certain they are in place. Replace when necessary. It is especially important to do this at the beginning of each new season.
  - Check swing seats, ropes, cables and chains monthly during usage season for evidence of deterioration. Replacement should be made of any swing seat that has developed cracks in the plastic seats. Ropes, cables and chains should be removed and replaced if excessive wear is found. Contact Gorilla for warranted replacement parts.
  - For rusted areas on metallic members such as monkey bars, hand supports brackets, etc.; sand and repaint, using a non lead-based paint meeting the requirements of Title 16 CRF Part 1303.
  - Inspect wood parts monthly. The grain of the wood sometimes will lift in the dry season causing splinters to appear. Light sanding may be necessary to maintain a safe playing environment. If you are treating your play set with stain regularly, it will help prevent severe checking/splitting and other weather damage.
  - Once or twice a year, depending on your climate conditions, you must apply some type of protection (sealant) to the wood of your unit. Prior to the application of sealant, lightly sand any “rough” spots on your set. Please note this is a requirement of your warranty.
  - Creating and maintaining the play set on a level location is very important. As your children play, your play set will slowly dig its way into the soil, and it is very important that it settles evenly. Make sure the play set is level and true once each year or at the beginning of each play season.
  - Rake the surface periodically to prevent compaction and maintain appropriate depths.
- Disposal Instructions: When the play set is no longer desired, it should be disassembled and disposed of in such away that no unreasonable hazards will exist at the time the unit is discarded.

# Play Set Surfacing Recommendations:

Below are some of the recommendations that the U.S. Consumer Product Safety Commission (CPSC) offers from its Handbook for Public Playground Safety. The guide can be downloaded in full at [www.cpsc.gov/cpscpub/pubs/325.pdf](http://www.cpsc.gov/cpscpub/pubs/325.pdf)

**1. Protective Surfacing** - Since almost 60% of all injuries are caused by falls to the ground, protective surfacing under and around all playground equipment is the most critical safety factor on playgrounds.

Certain manufactured synthetic surfaces also are acceptable; however, test data on shock absorbing performance should be requested from the manufacturer.

Asphalt and concrete are unacceptable. They do not have any shock absorbing properties. Similarly, grass and turf should not be used. Their ability to absorb shock during a fall can be reduced considerably through wear and environmental conditions.

Certain loose-fill surfacing materials are acceptable. Surfacing materials are acceptable, such as the types and depths shown in the table.

## Fall Heights and Materials

Type Of Material	6 in. depth	9 in. depth	12 in. depth
Double-Shredded bark mulch	6' Fall Height	10' Fall Height	11' Fall Height
Wood Chips	6' Fall Height	7' Fall Height	12' Fall Height
Fine Sand	5' Fall Height	5' Fall Height	9' Fall Height
Shredded Tires*	10-12' Fall Height	N/A	N/A
Fine Gravel	6' Fall Height	7' Fall Height	10' Fall Height

\*This data is from tests conducted by independent testing laboratories on a 6-inch depth of uncompressed shredded tire samples produced by four manufacturers. The tests reported critical heights, which varied from 10 feet to greater than 12 feet. It is recommended that persons seeking to install shredded tires as a protective surface request test data from the supplier showing the critical height of the material when it was tested in accordance with ASTM F1292.

*It should be recognized that all injuries due to falls cannot be prevented no matter what surfacing material is used.*

**2. Fall Zones** - A fall zone, covered with a protective surfacing material, is essential under and around equipment where a child might fall. This area should be free of other equipment and obstacles onto which a child might fall. Stationary climbing equipment and slides should have a fall zone extending a Minimum of 6' in all directions from the perimeter of the equipment.

Swings should have a fall zone extending a minimum of 6' from the outer edge of the support structure on each side. The fall zone in front and back of the swing should extend out a minimum distance of twice the height of the swing as measured from the ground to the top of the swing support structure.

## LEVELING YOUR FORT DURING ASSEMBLY

- Complete the steps which will be the basic frame of the fort {i.e. four corner posts with base (sand box boards) and deck supports}
- Position in the most level area chosen for the play set, keeping in mind the location and size of the swing beam, ladder, slides, etc. that extend off the fort.
- Once the frame is in the final position, check for vertical and horizontal levelness to determine which side(s) will need to be dug into the ground to level the play set.
- With a shovel, score the ground around the outside edges of the sandbox boards on the 'high' side of the fort. This is the area that will be dug in. Make sure to score deep enough; the scored lines will be your digging template.
- Push the frame off and away from the scored area, far enough to dig and remove dirt to reach the appropriate depth.
- Dig a channel along the scored line(s) for the base of the fort (corner post and sandbox boards) to rest into. Dig the channel(s) to the same level depth. The bottom of the channel(s) should be level to each other so your frame doesn't teeter or rock because the channel(s) are uneven.
- Once you have removed enough grass and dirt, slide/push the frame into the channel(s). Place a level on the vertical and horizontal boards of the frame to determine if enough soil, or too much, was removed.
- Repeat this process until the basic frame is plumb and level and in its final position before completing the rest of the assembly.
- Measure to make sure fort is square.

**Important: if you require a channel depth of more than 6", then we recommend you have your play set area professionally graded before completing assembly.**

*Example Play area:*

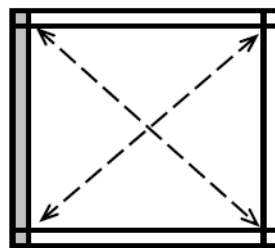
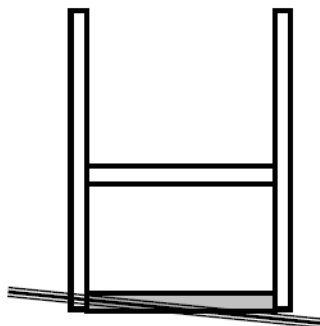

The diagonal measurements should be the same from corner post to corner post. If not, adjust corner posts so that the distance is equal.

■ = Area to be scored and channeled for levelness

# General Info to Review Before Installation

- Depending on your experience, assembly of Gorilla Playsets can take as little as 6 hours up to 24 hours, depending on size, after inventory of parts; therefore, we recommend you set aside a full two days for assembly.
- Identify all of the parts for your play set. Empty each box and lay out boards so you can see each part. Your instruction book will have detailed drawings that will make it easy for you to recognize individual parts. Keep all hardware and metal parts separate from wooden pieces.
- After everything is laid out, check carefully to ensure all parts are present. Make sure there are no broken boards.
- Find an area to sort your hardware. It is best to open the hardware on a solid surface so that you do not lose any pieces in the grass. This will save time and familiarize you with all the different pieces in the hardware bag.
- Important note: Wood has some natural defects such as knots, surface cracks, etc... We reject parts that are structurally defective. We use a high quality lumber in our structures; however, you should inspect each part for splinters or rough spots and sand them smooth to prevent injury.
- After familiarizing yourself with all of the components, read all instructions thoroughly. Reading instructions after you have studied the parts will help you understand more clearly the installation process, and help to eliminate unnecessary mistakes.
- Pay close attention to the diameter and length of each bolt and screw.
- Never tighten hardware completely at first. It helps to have some adjustment for bolt alignment while you are attaching parts together. After everything is square, tighten each joint.
- After the main unit is assembled it is critical that the floor is level and square. If the main frame is not level, the walls and floor will be out of square.
- After you complete installation, make sure every bolt, screw, and nut is tight, and every board is secure. Wood will expand and contract with the seasons.
- Check all bolt connections and swing hangers every two weeks.
- Place the set on level ground, not less than 6ft from any structure or obstruction such as a fence, garage, house, overhanging branches, laundry lines, or electrical wires.

**This page is a list of definitions and explanations used throughout our instructions to aid you in the assembly of your play set.**

**Offset Holes-** Throughout the installation procedures we will refer to parts with offset holes. This refers to the orientation of the holes on the board. An offset hole is one that is closer to one side than it is the other or in other words, it is not centered on the board. In the procedures you will be instructed to attach the boards with the holes offset up or with the holes offset down. This refers to which side of the board the hole/holes should be closer to. Offset holes up= hole/holes will be closer to the top of the board. Offset holes down= hole/holes will be closer to the bottom of the board. Note: some parts do not have offset holes, but instead the holes are on center. Therefore there will not be any reference to how to offset these parts.

**EXAMPLE OF OFFSET HOLES UP**



**EXAMPLE OF OFFSET HOLES DOWN**



**Counter-sunk holes-** Many of the parts that will be used have counter-sunk holes. A counter-sunk hole is one that surrounds one side of a thru hole, but does not extend through the wood it's self. When using a counter-sunk hole the bolt will be inserted through the thru hole and either the head of the bolt and washer or nut and washer will occupy the counter sunk hole.

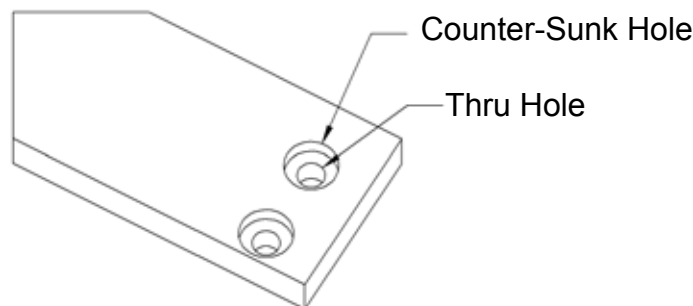

**Lag Screws-** Lag screws are used in the construction of our play sets to enhance the structural integrity of the unit. There will not be predrilled holes in the post for lag screw installation. Lag screws are self-tapping, though if you are using a manual socket wrench it may be necessary to tap the head of the lag screw with a hammer. You should also be sure to tighten the lags completely. Power tools such as an impact wrench or power drill should have enough torque to drive the lag screws without using a hammer, but make sure not to over tighten as this can cause the threads to “strip out” in the post.

# Common Installation Practice Installing T-nuts

When installing T-nuts into the wood, use a smooth faced hammer to set the face of the T-nut flush into the wood

Corner Post

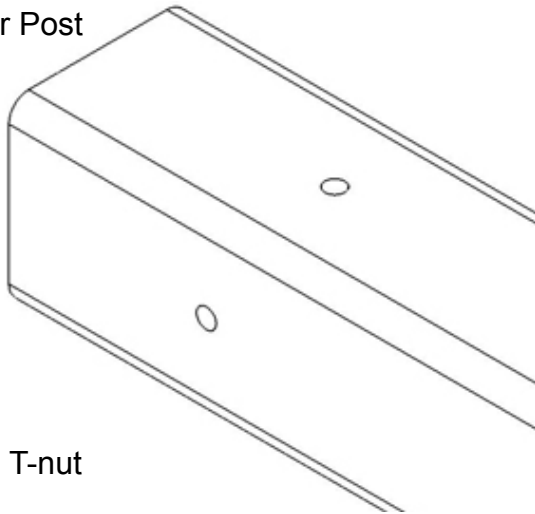

T-nut

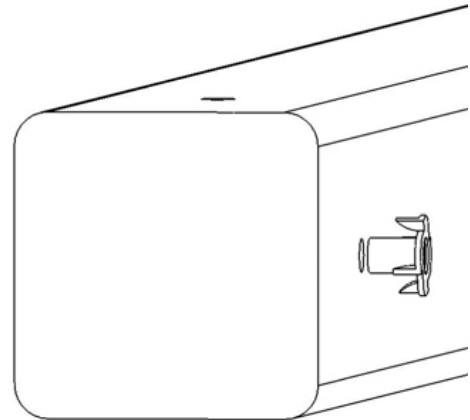

Insert the barrel of the T-nut into the predrilled hole. Using a smooth faced hammer, drive the T-nut until the face of the T-nut is flush to the wood.

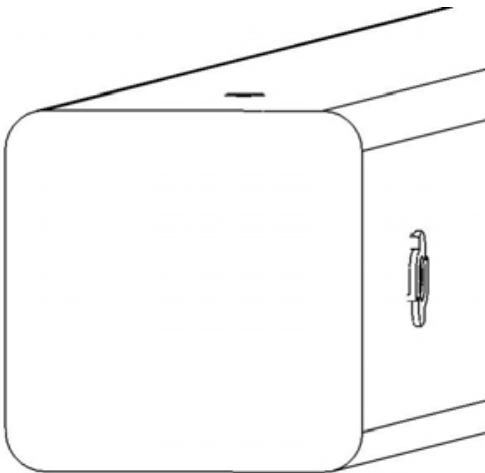

This picture shows the T-nut insert and installed flush to the wood.

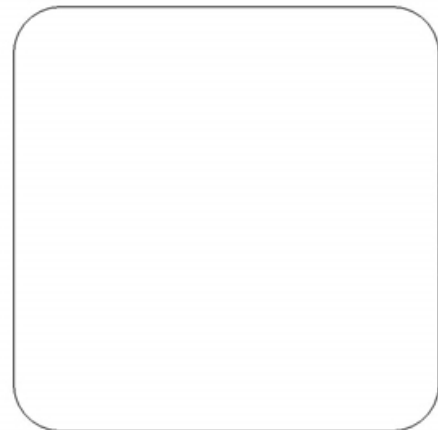

This picture shows an end view of the T-nut insert and installed flush to the wood.

**WARNING: DO NOT EMBED THE TOP OF THE T-NUT INTO THE FACE OF THE WOOD**

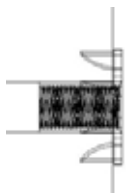

Cross Section end views, you are looking at an Xray view of the post and T-nut. The barrel of the T-nut is in the corner post the line is the face of the wood.

**Please familiarize yourself with the manual, parts/components and general construction process of your new playset before getting started.**

**SITE PLAN:**

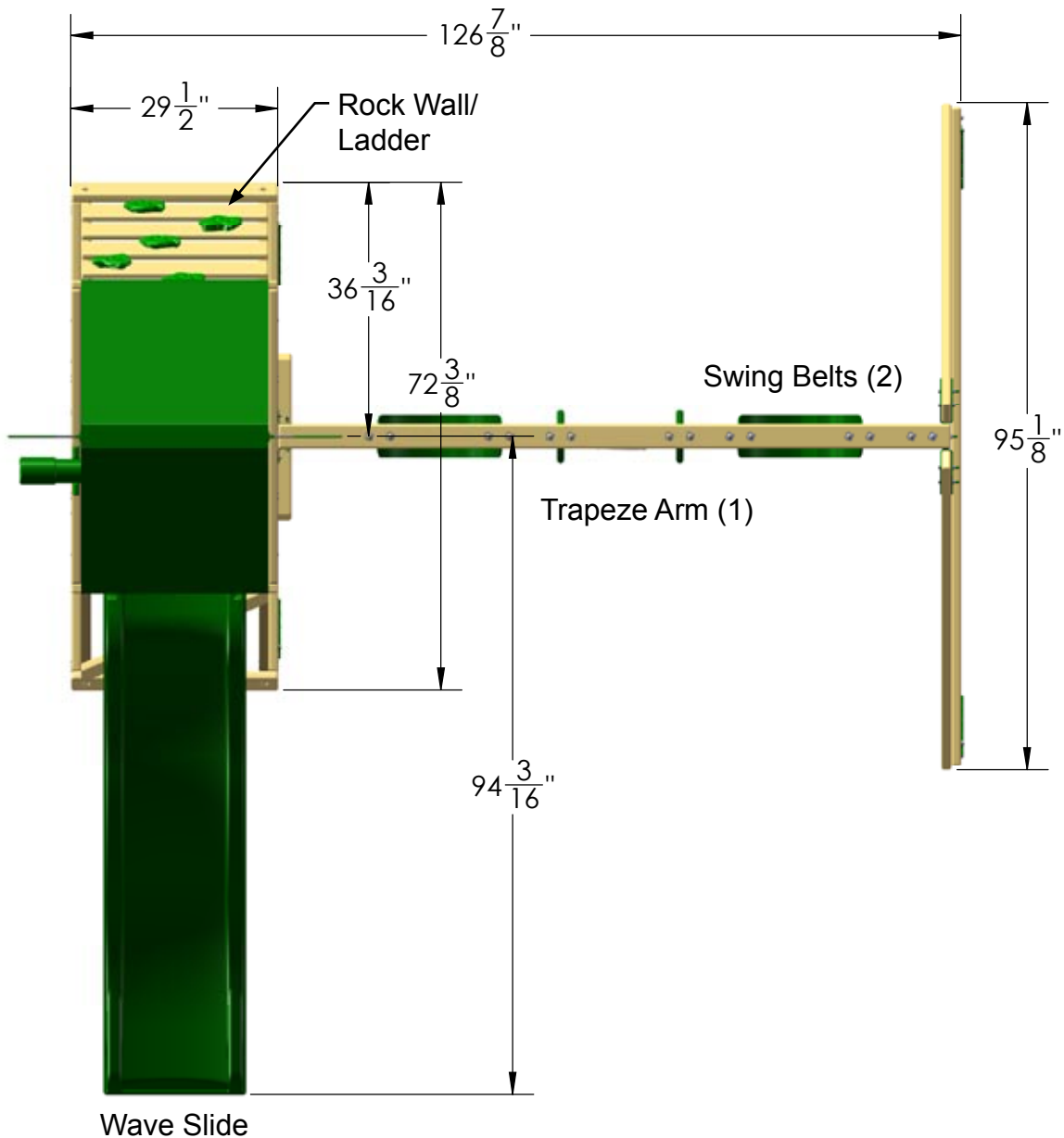

Playset height: 8 feet - 4 inches

Swing Beam height: 79-1/2 inches

Approximate assembly time: 4 to 6 hours

**(6) foot unobstructed safety perimeter around playset recommended.**

## **REQUIRED TOOL LIST:**

- \_\_\_ Standard or Cordless Drill w/ Phillips Bit (#2 square bit provided)
- \_\_\_ 1/8" Drill Bit
- \_\_\_ 3/8" Drill Bit
- \_\_\_ 1/2" Wrench and Socket
- \_\_\_ 1/2" Deep Well Socket
- \_\_\_ 9/16" Deep Well Socket
- \_\_\_ 9/16" Wrench and Socket
- \_\_\_ Level
- \_\_\_ Tape Measure
- \_\_\_ Extension Cord (if using standard drill)
- \_\_\_ Hammer
- \_\_\_ Pencil
- \_\_\_ Locking Pliers (Vise Grips)
- \_\_\_ Shovel

## **KIT CONTENTS**

### **Swings, Slides, Accessories:**

- \_\_\_ (Qty ) Description
- \_\_\_ (2) Swingbelts w/ Chains
- \_\_\_ (1) 8ft. Wave Slide
- \_\_\_ (1) Journey Assembly Manual
- \_\_\_ (5) Rock Wall Grips (assorted colors)
- \_\_\_ (1) Trapeze Swing
- \_\_\_ (1) Telescope
- \_\_\_ (2) Plastic Safety Handles
- \_\_\_ (2) Flags
- \_\_\_ (4) Ground Stakes

### **Fort and Swing Beam Hardware:**

*see following pages*

### **Wood Components:**

*see following pages*

**Use the ruler to the right to measure your bolts and screws. Picture views shown below are 1:1 scale and can be used to match bolt and screw sizes.**

3/8" Lock Nut  
Qty: 14



5/16" Lock Nut  
Qty: 7



#8 x 1-1/4"  
Wood Screw  
Qty: 2



#8 x 2"  
Wood Screw  
Qty: 66



#8 x 2-1/2"  
Wood Screw  
Qty: 48



#8 x 3"  
Wood Screw  
Qty: 6



5/16" x 4-1/2"  
Hex Bolt  
Qty: 6



5/16" x 3-1/2"  
Hex Bolt  
Qty: 2



5/16" x 2-3/4"  
Hex Bolt  
Qty: 2



5/16" x 2-1/2"  
Hex Bolt  
Qty: 52



5/16" x 1-1/2"  
Hex Bolt  
Qty: 4



5/16" x 1"  
Hex Bolt  
Qty: 1



1/4" Washer  
Qty: 8



5/16" Washer  
Qty: 80



3/8" Washer  
Qty: 14

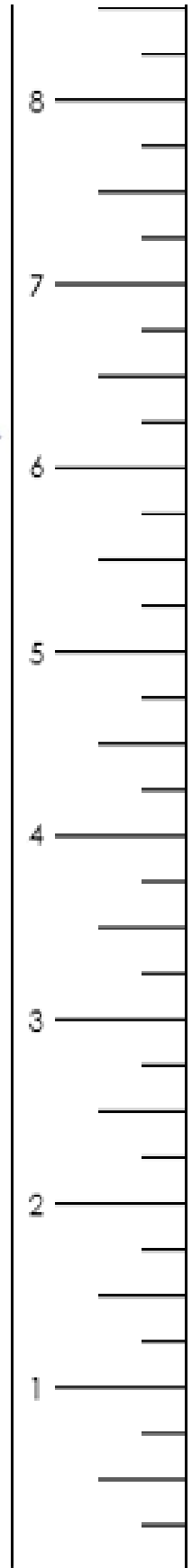

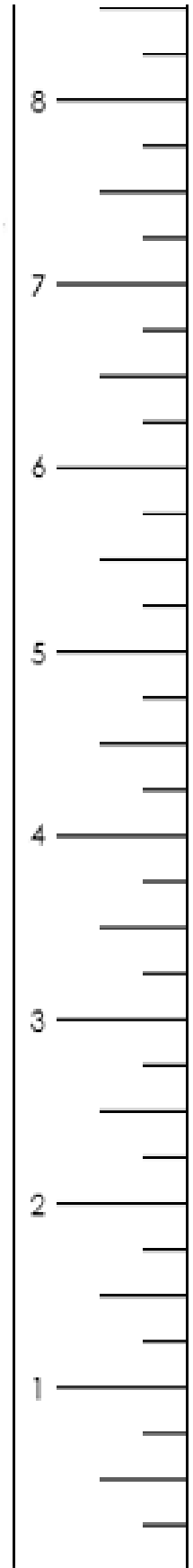
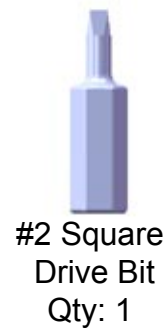
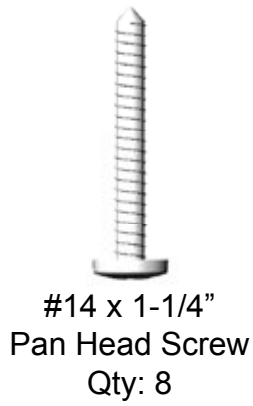
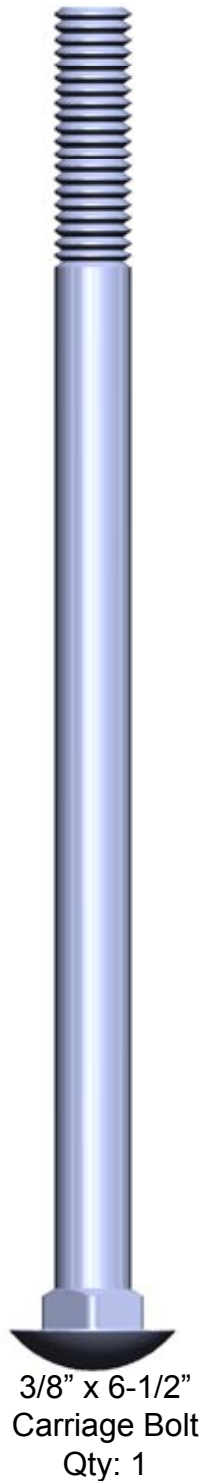

Use the ruler to the right to measure your bolts and screws. Picture views shown below are 1:1 scale and can be used to match bolt and screw sizes.

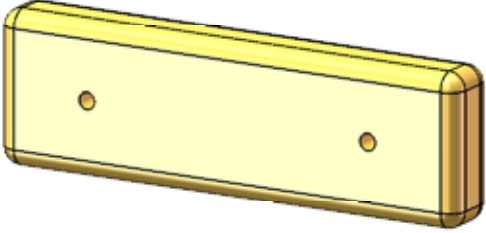
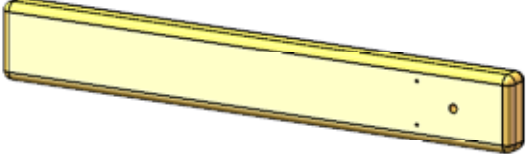
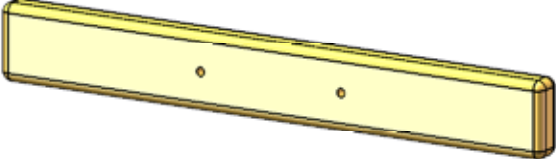
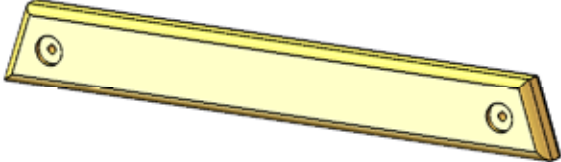
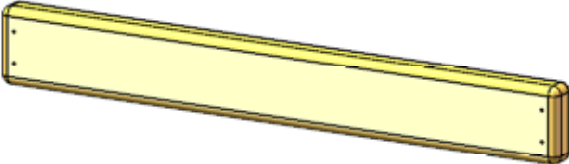
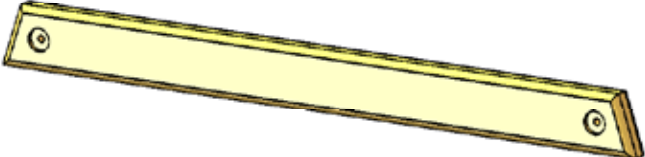

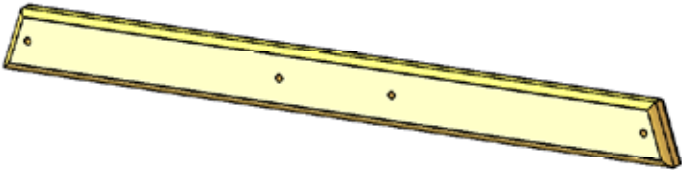
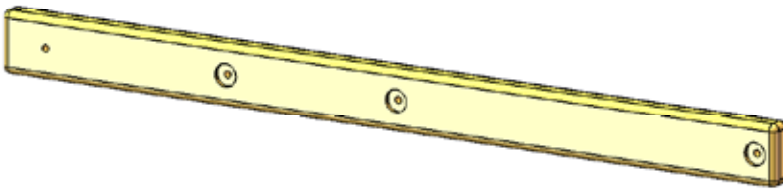
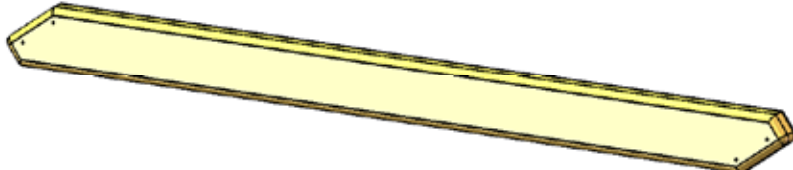
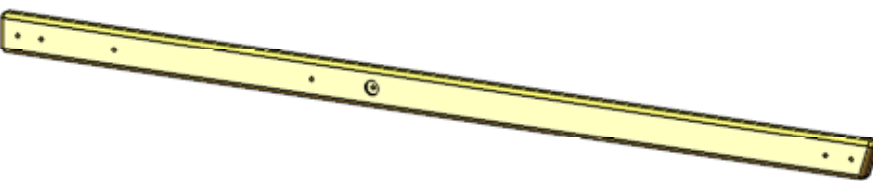
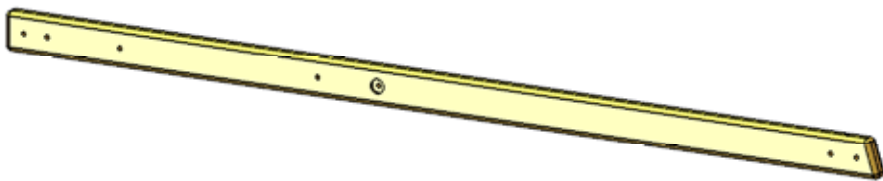
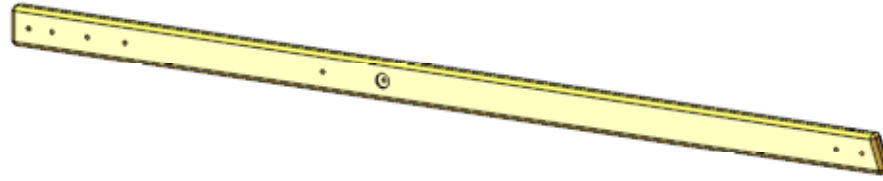

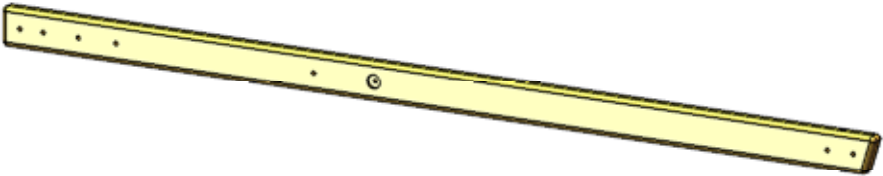
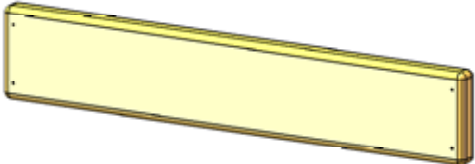
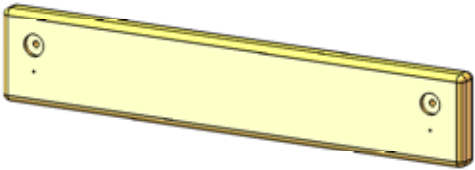
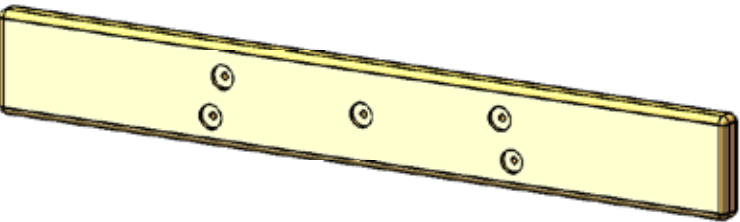
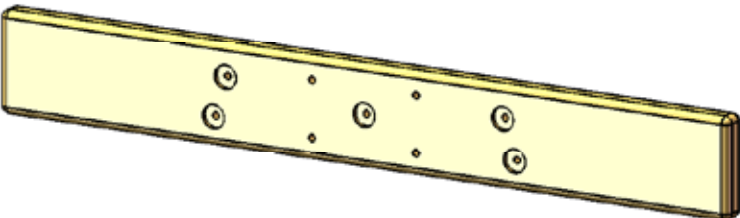
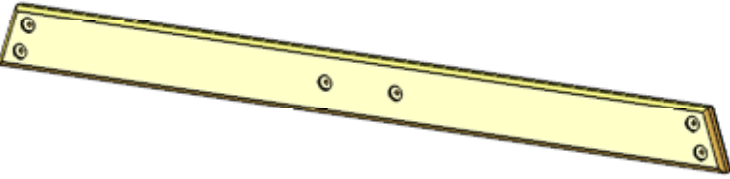

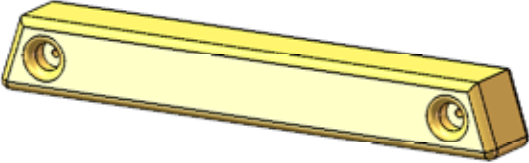

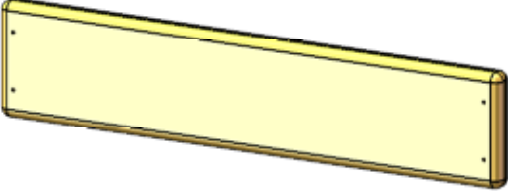
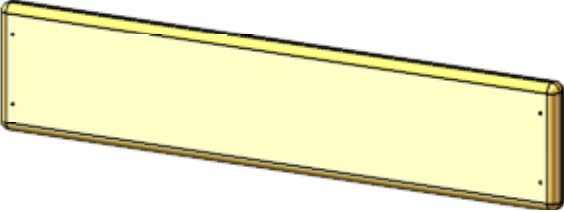
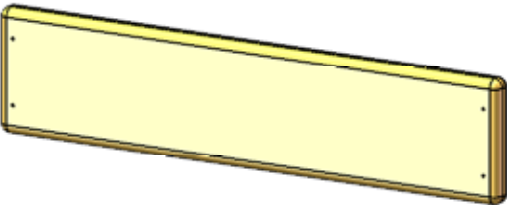
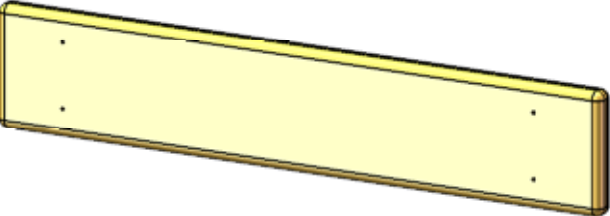

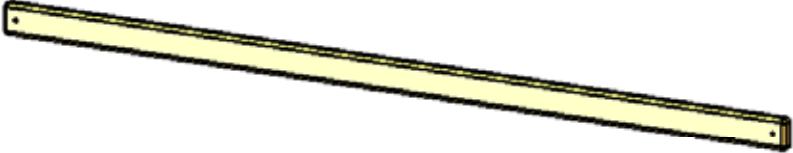

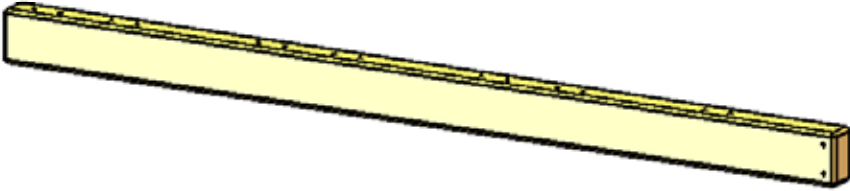
Picture	Description	Qty.
	2 x 4 x 11" Table Support	<b>2</b>
	2 x 4 x 24-1/2" Center Tarp Support	<b>2</b>
	2 x 4 x 26" Seat Support	<b>2</b>
	2 x 4 x 26-1/4" Upper Slat Board	<b>2</b>
	2 x 4 x 26-3/4" Center Tarp Board	<b>1</b>
	2 x 4 x 38-1/16" Lower Slat Board	<b>2</b>

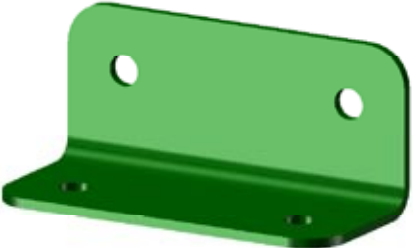
Picture	Description	Qty.
	2 x 4 x 40-1/4" Deck Support	<b>2</b>
	2 x 4 x 46-1/2" Table Leg	<b>4</b>
	2 x 4 x 47-3/16" Diagonal Brace	<b>1</b>
	2 x 4 x 84" Corner Post Left - Front	<b>1</b>
	2 x 4 x 84" Corner Post Left - Rear	<b>1</b>
	2 x 4 x 84" Corner Post Right - Front	<b>1</b>

Picture	Description	Qty.
	2 x 4 x 84" Corner Post Right - Rear	<b>1</b>
	2 x 6 x 29-1/2" End Tarp Board	<b>2</b>
	2 x 6 x 29-1/2" Front - Rear Panel Board	<b>2</b>
	2 x 6 x 42" Side Tarp Support - Left	<b>1</b>
	2 x 6 x 42" Side Tarp Support - Right	<b>1</b>
	2 x 6 x 70" Bottom Panel Board	<b>2</b>

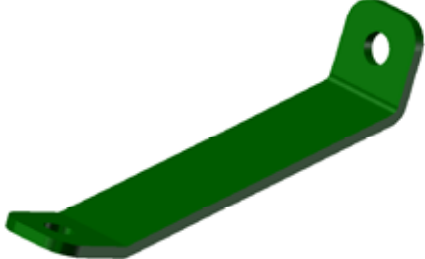
Picture	Description	Qty.
	<p>4 x 4 x 24" Swing Beam Support</p>	<p><b>1</b></p>
	<p>5/4 x 2-5/8 x 20-1/4" Panel Slat</p>	<p><b>10</b></p>
	<p>5/4 x 5 x 24" Deck Spacer</p>	<p><b>2</b></p>
	<p>5/4 x 5-1/2 x 26-3/4" Rock Wall - Deck Panel Board</p>	<p><b>6</b></p>
	<p>5/4 x 5-3/8 x 24" Seat - Table Board</p>	<p><b>4</b></p>
	<p>5/4 x 5-3/8 x 29" Deck Board</p>	<p><b>5</b></p>

Picture	Description	Qty.
	<p>2 x 4 x 94" Swing Leg Cross Member</p>	<p><b>1</b></p>
	<p>2 x 4 x 86" Swing Leg</p>	<p><b>2</b></p>
	<p>4 x 6 x 96" Swing Beam</p>	<p><b>1</b></p>
<p>(Not Shown)</p>	<p>Hardware Box</p>	<p><b>1</b></p>
	<p>90° Green Bracket</p>	<p><b>1</b></p>
	<p>2" x 2" x 4-1/2" Bracket</p>	<p><b>2</b></p>

Picture	Description	Qty.
	Swing Leg Bracket	1
	Swing Leg Angle Bracket	1
	Tarp 26-3/4" x 65-3/4"	1
	Flag Kit	2
	Telescope	1
	Climbing Rocks	5

Picture	Description	Qty.
	8' Wave Slide	<b>1</b>
	Swing w/Chains Trapeze Bar w/Chains	<b>2</b> <b>1</b>
	Safety Handle	<b>2</b>
	Ground Stake	<b>4</b>
	Mini Iron Ductile Swing Hanger	<b>6</b>

## Step 1: Installing T-Nuts (Right Front Corner Post)

1: Locate one 2 x 4 x 84" Corner Post (Right - Front) The top will have four holes. The countersunk hole is on the BACK side that you cannot see in the picture.

2: Use a hammer to set t-nuts after inserting them into the holes shown in the diagram.

3: The barrel of the t-nut should go in the hole first. Hammer the t-nut until it is flush/almost flush to the corner post.

Four holes in top of the Corner Post on this face.

T-Nut

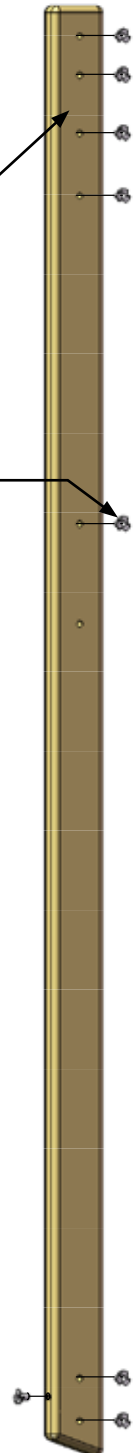

## Step 2: Installing T-Nuts (Right Rear Corner Post)

1: Locate one 2 x 4 x 84" Corner Post (Right - Rear). The top will have four holes. The countersunk hole is on the BACK side that you cannot see in the picture.

2: Use a hammer to set t-nuts after inserting them into the holes shown in the diagram.

3: The barrel of the t-nut should go in the hole first. Hammer the t-nut until it is flush/almost flush to the corner post.

Four holes in top of the Corner Post on this face.

T-Nut

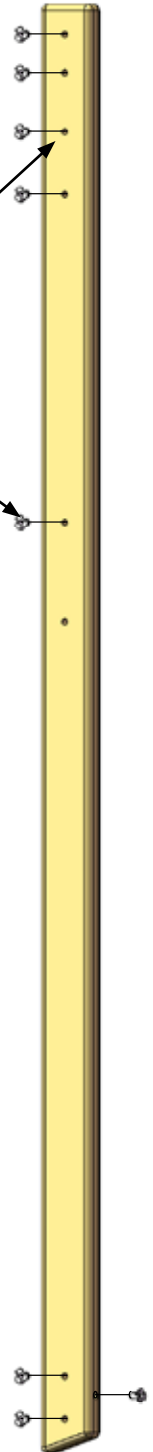

### Step 3: Installing T-Nuts (Left Front Corner Post)

1: Locate one 2 x 4 x 84" Corner Post (Left Front). The top will have three holes. The countersunk hole is on the BACK side that you cannot see in the picture.

2: Use a hammer to set t-nuts after inserting them into the holes shown in the diagram.

3: The barrel of the t-nut should go in the hole first. Hammer the t-nut until it is flush/almost flush to the corner post.

Three holes in top of the Corner Post on this face.

T-Nut

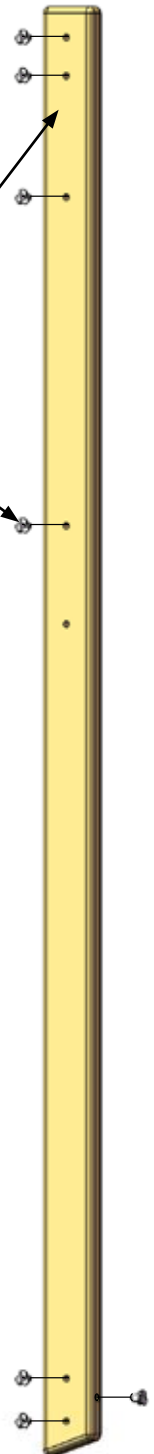

## Step 4: Installing T-Nuts (Left Rear Corner Post)

1: Locate one 2 x 4 x 84" Corner Post (Left - Rear). The top will have three holes. The countersunk hole is on the BACK side that you cannot see in the picture.

2: Use a hammer to set t-nuts after inserting them into the holes shown in the diagram.

3: The barrel of the t-nut should go in the hole first. Hammer the t-nut until it is flush/almost flush to the corner post.

Three holes in top of the Corner Post on this face.

T-Nut

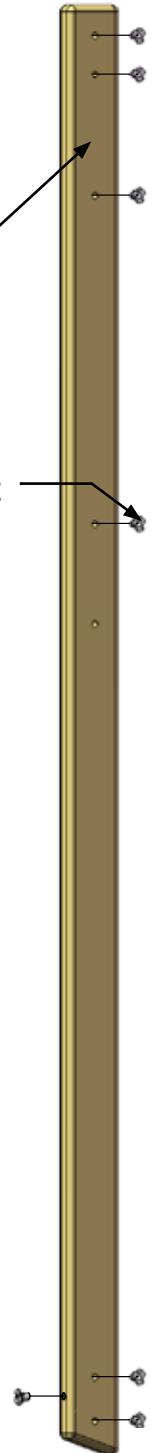

## Step 5: Installing T-Nuts (Deck Supports)

- 1: Locate two 2 x 4 x 40-1/4" Deck Supports.
- 2: Use a hammer to set t-nuts after inserting them into the holes shown in the diagram.
- 3: The barrel of the t-nut should go in the hole first. Hammer the t-nut until it is flush/al-most flush to the Deck Support.
- 4: Repeat substeps 2 and 3 for the other Deck Support.

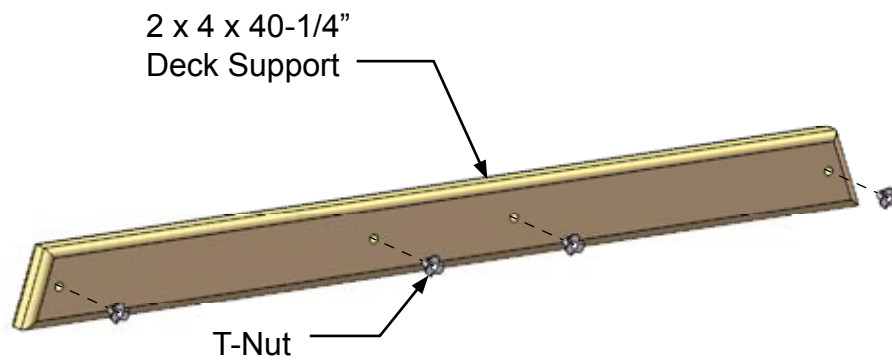

## Step 6: Right Side Frame Assembly (Outside Face)

- 1: Place the Right Front and Right Rear corner posts as shown below. The flange of the T-nuts should be on the INSIDE of the corner posts facing each other at the bottom.
- 2: The flange of the T-nuts should be on the BACK side of the corner posts where a board is attached.
- 3: Attach each board to the corner posts with 5/16" x 2-1/2" hex bolts and 5/16" washers.
- 4: Turn the assembly over and hammer four T-Nuts into the back of the 2 x 6 x 42" Side Tarp Support - Right.

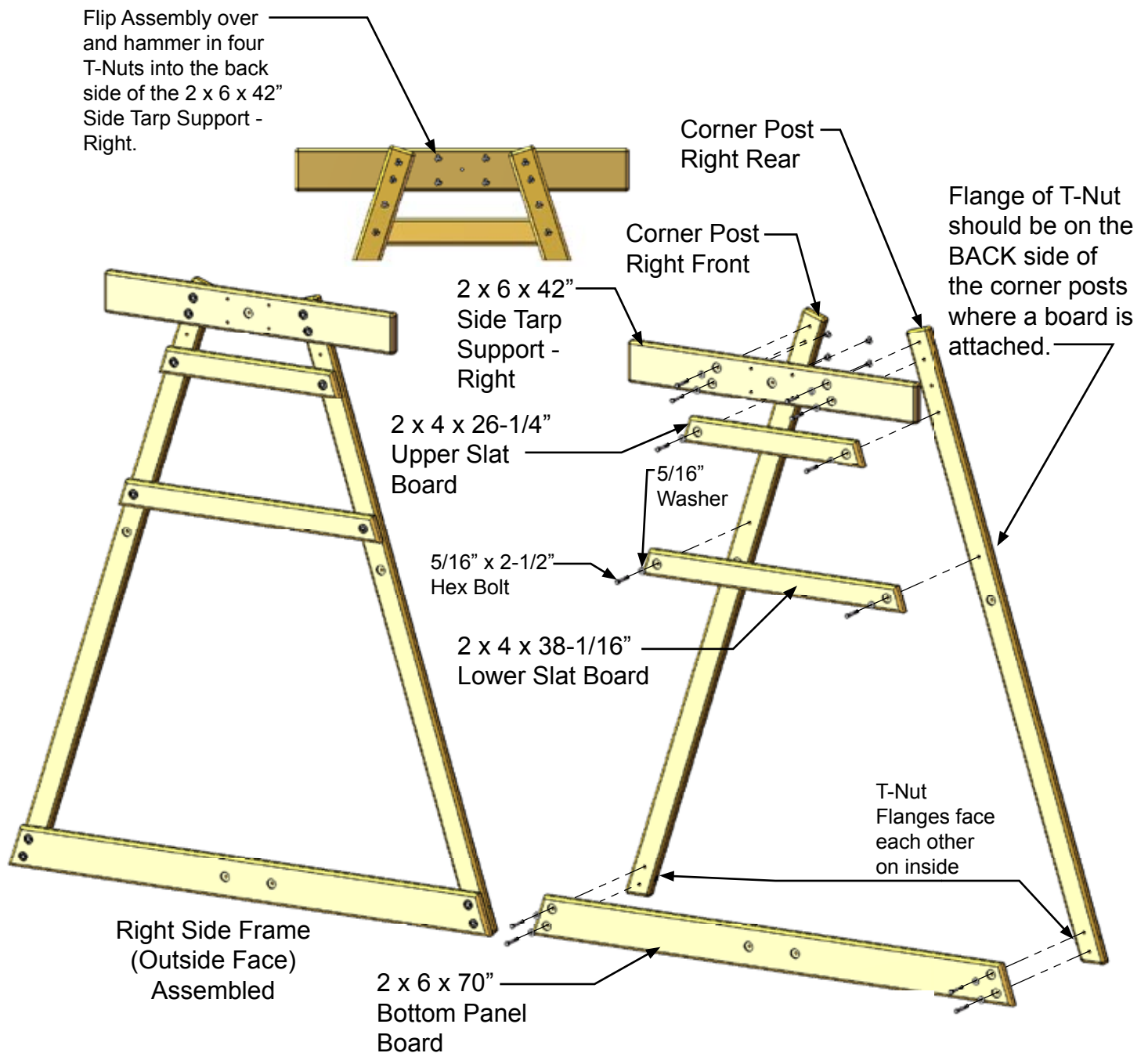

## Step 7: Right Side Frame Assembly (Inside Face)

- 1: The Right Side Frame Assembly should still be turned over from putting in four T-Nuts in the previous step. If the frame is not turned over then turn it over now.
- 2: The flange of the T-nuts should be on the side of the Deck Support shown below.
- 3: Attach the 2 x 4 x 40-1/4" Deck Support to the corner posts with 5/16" x 2-1/2" hex bolts and 5/16" washers.
- 4: Set the completed Right Side Frame Assembly aside and proceed to the next step to build the Left Side Frame.

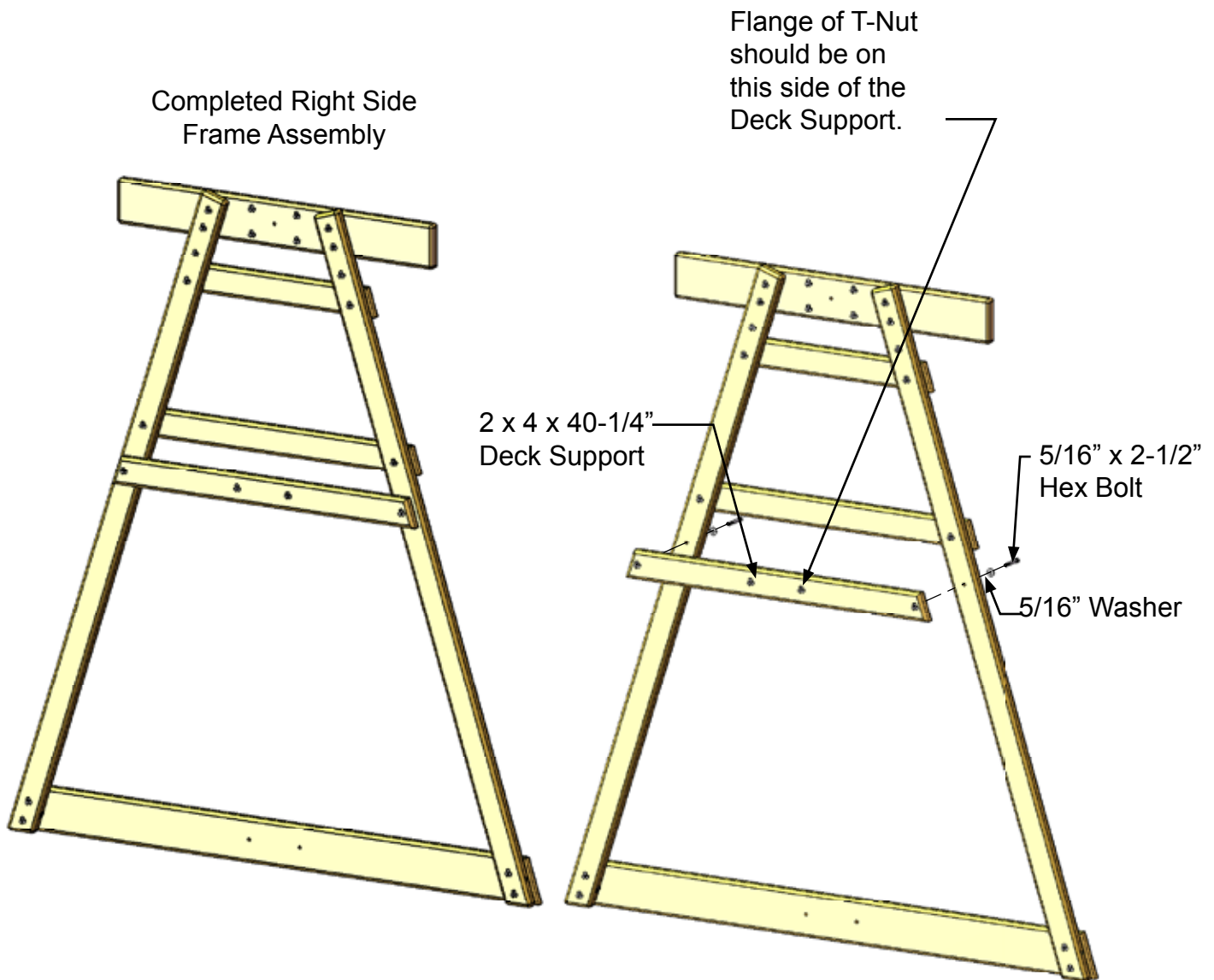

## Step 8: Left Side Frame Assembly (Outside Face)

- 1: Place the Left Front and Left Rear corner posts as shown below. The flange of the T-nuts should be on the INSIDE of the corner posts facing each other at the bottom.
- 2: The flange of the T-nuts should be on the BACK side of the corner posts where a board is attached.
- 3: Attach each board to the corner posts with 5/16" x 2-1/2" hex bolts and 5/16" washers.

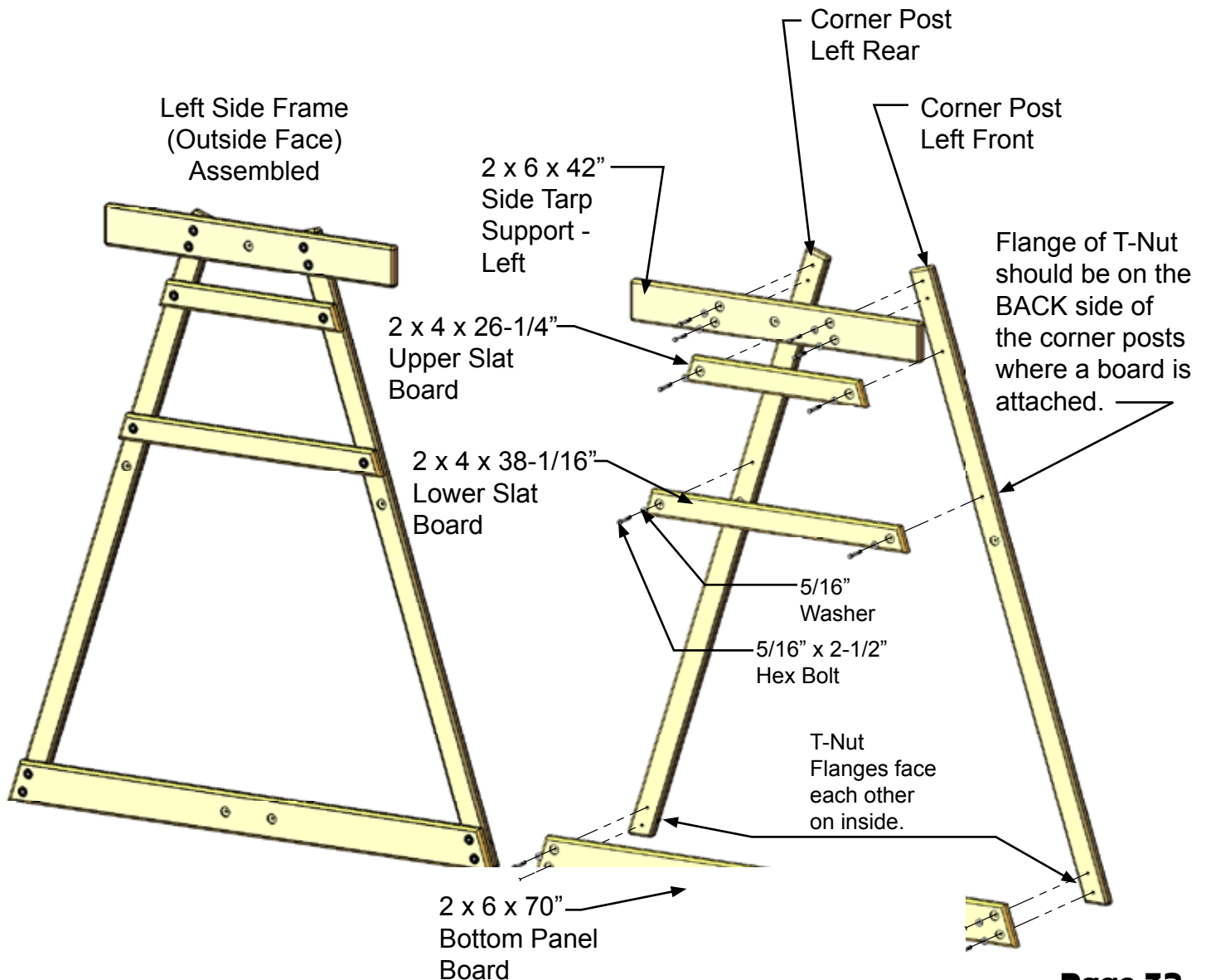

## Step 9: Left Side Frame Assembly (Inside Face)

- 1: Flip the Left Side Frame Assembly over.
- 2: The flange of the T-nuts should be on the side of the Deck Support shown below.
- 3: Attach the 2 x 4 x 40-1/4" Deck Support to the corner posts with 5/16" x 2-1/2" hex bolts and 5/16" washers.
- 4: Set the completed Left Side Frame Assembly aside and proceed to the next step.

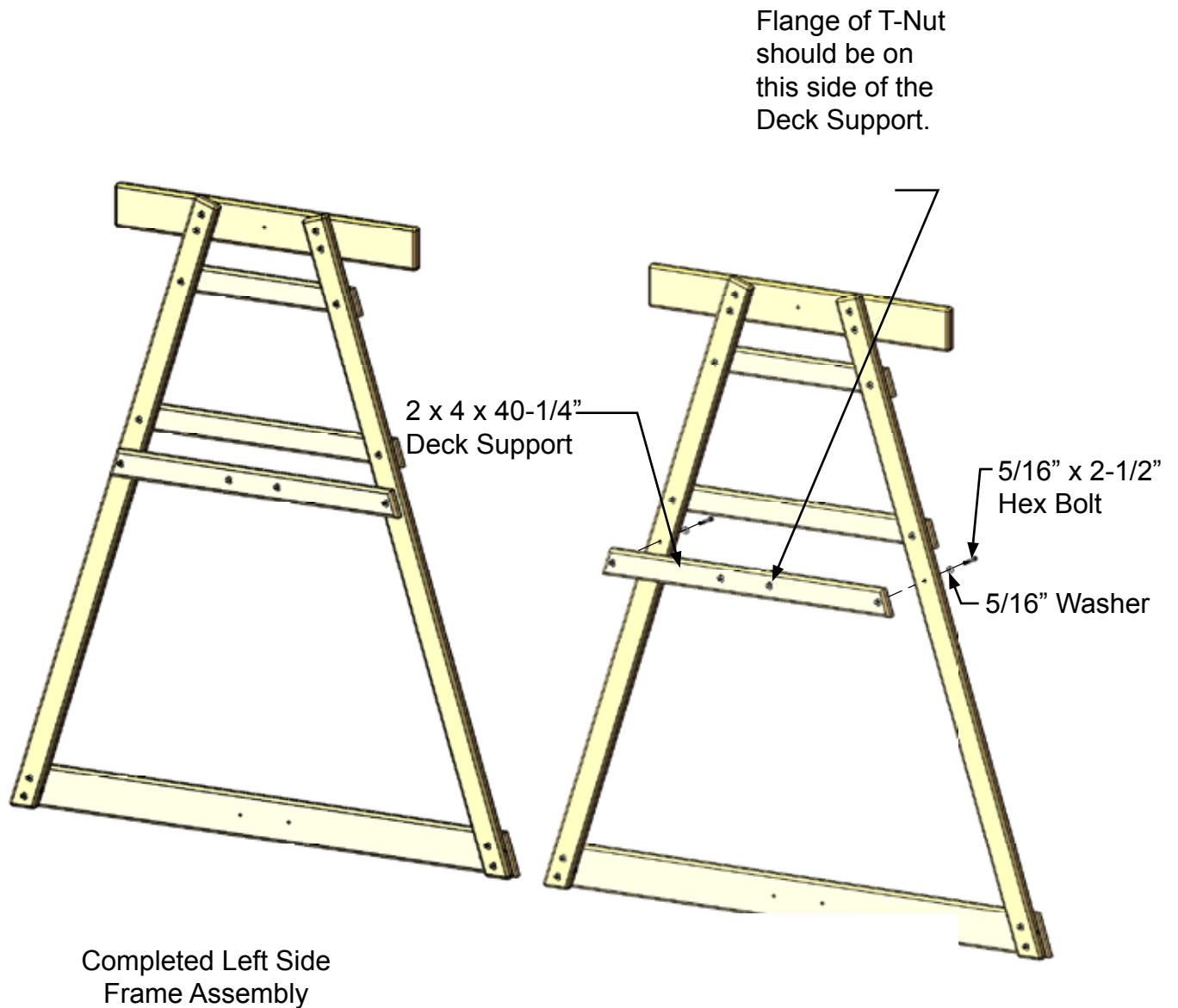

## Step 10: Picnic Table parts (T-Nuts)

1: Hammer a t-nut into the side opposite the countersunk holes in the 2 x 4 x 46-1/2" Table Leg as shown below. Repeat this three more times for the other three Table Legs.

2: Hammer two t-nuts into the 2 x 4 x 11" Table Support as shown below. Repeat one more time for the other Table Support..

3: Hammer two t-nuts into the 2 x 4 x 26" Seat Support as shown below. Repeat one more time for the other Seat Support.

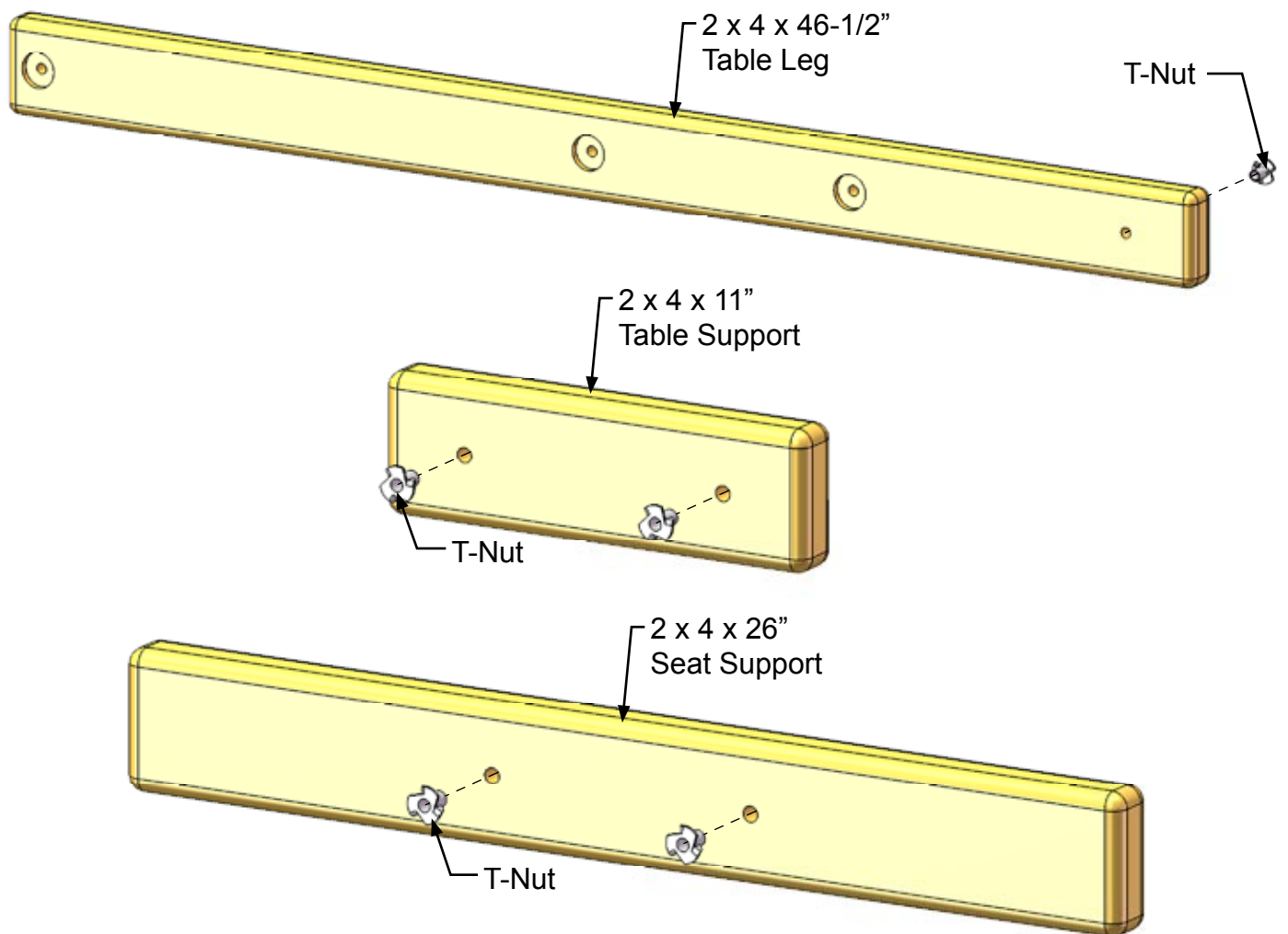

## Step 11: Picnic Table Legs

- 1: Locate the Right Side Frame Assembly.
- 2: Place the 2 x 4 x 46-1/2" Table Legs against the Deck Support at the top and BEHIND the 2 x 6 x 70 Bottom Panel Board at the bottom.
- 3: Line up the holes at the top and LOOSELY attach the Table Legs to the Deck Support with 5/16" x 2-1/2" hex bolts and 5/16" washers.
- 4: Line up the holes at the bottom and LOOSELY attach the Table Legs to the Deck Support with 5/16" x 2-1/2" hex bolts and 5/16" washers.
- 5: Tighten all the bolts.
- 6: Locate the Left Side Frame Assembly and repeat substeps 2 to 5.

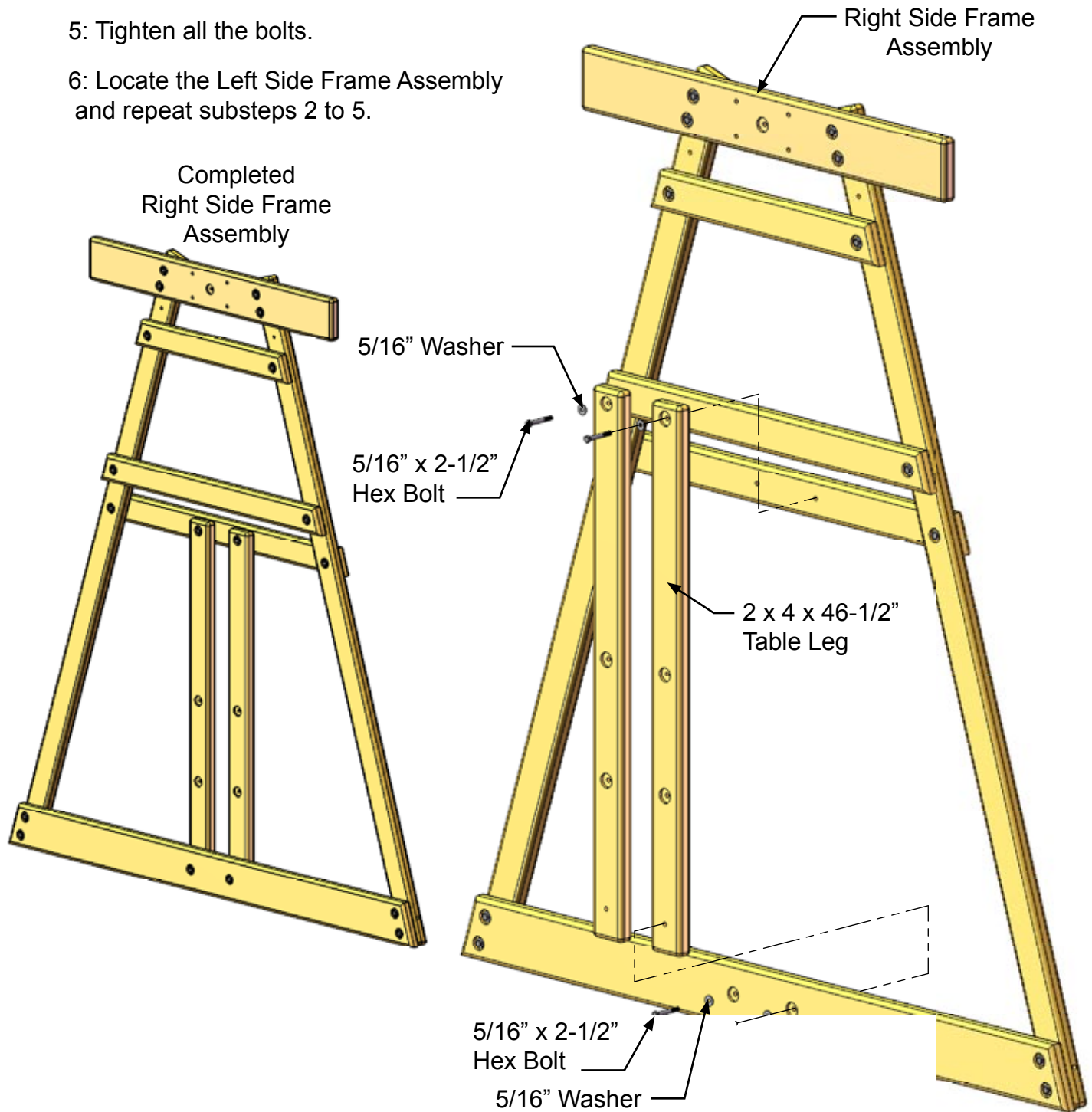

## Step 12: Picnic Table Supports

- 1: Locate the Right Side Frame Assembly.
- 2: Place the 2 x 4 x 11" Table Support behind the Table Legs as shown below. The flange of the t-nuts in the Table Support should be on the BACK side.
- 3: Line up the top most holes in the Table Legs to the holes in the Table Support and attach with 5/16" x 2-1/2" hex bolts and 5/16" washers.
- 4: Locate the Left Side Frame Assembly and repeat substeps 2 to 3.

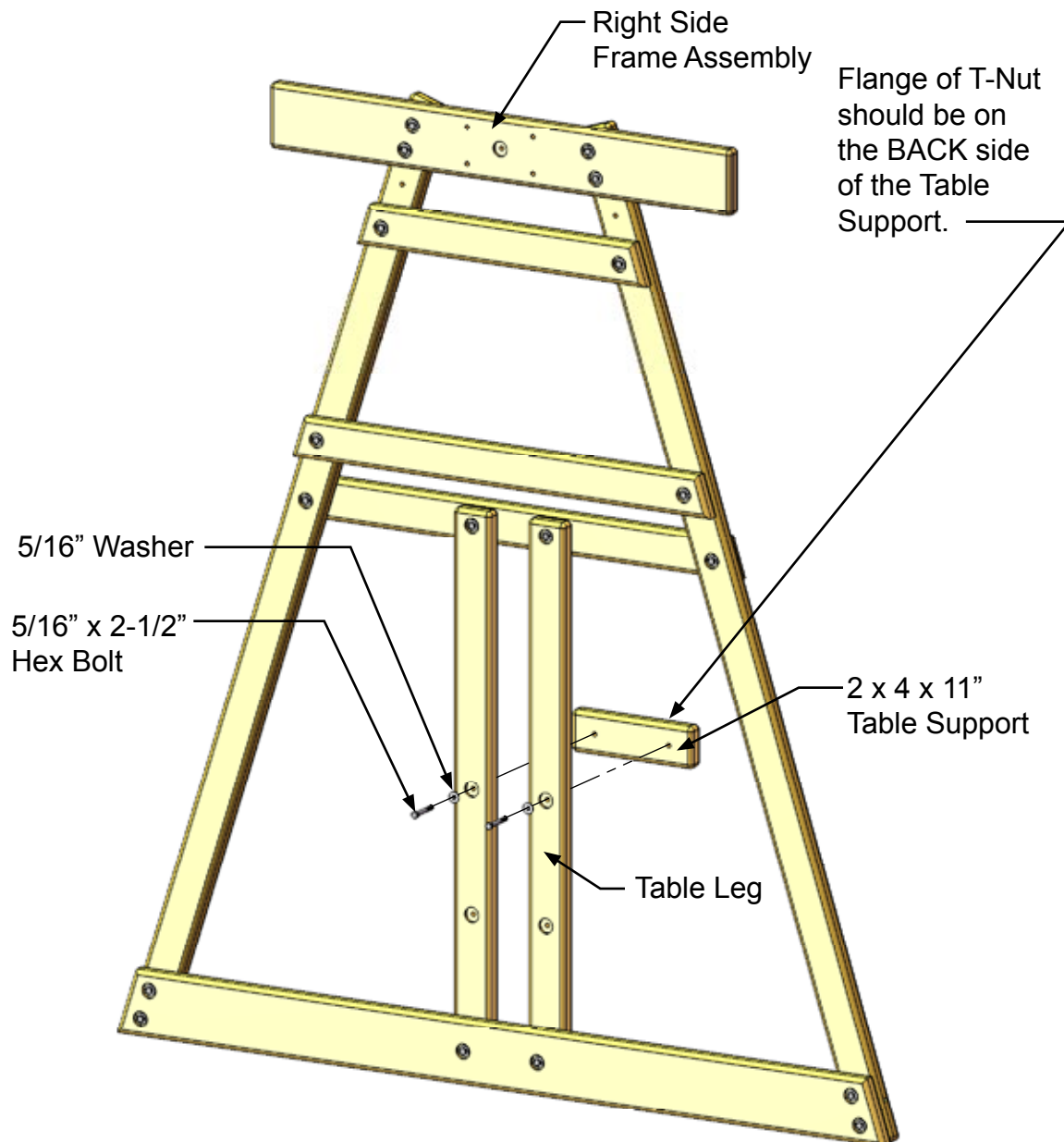

### Step 13: Picnic Table Seat Supports

- 1: Locate the Right Side Frame Assembly.
- 2: Place the 2 x 4 x 26" Seat Support behind the Table Legs as shown below. The flange of the t-nuts in the Seat Support should be on the BACK side.
- 3: Line up the bottom most holes in the Table Legs to the holes in the Seat Support and attach with 5/16" x 2-1/2" hex bolts and 5/16" washers.
- 4: Locate the Left Side Frame Assembly and repeat substeps 2 to 3.

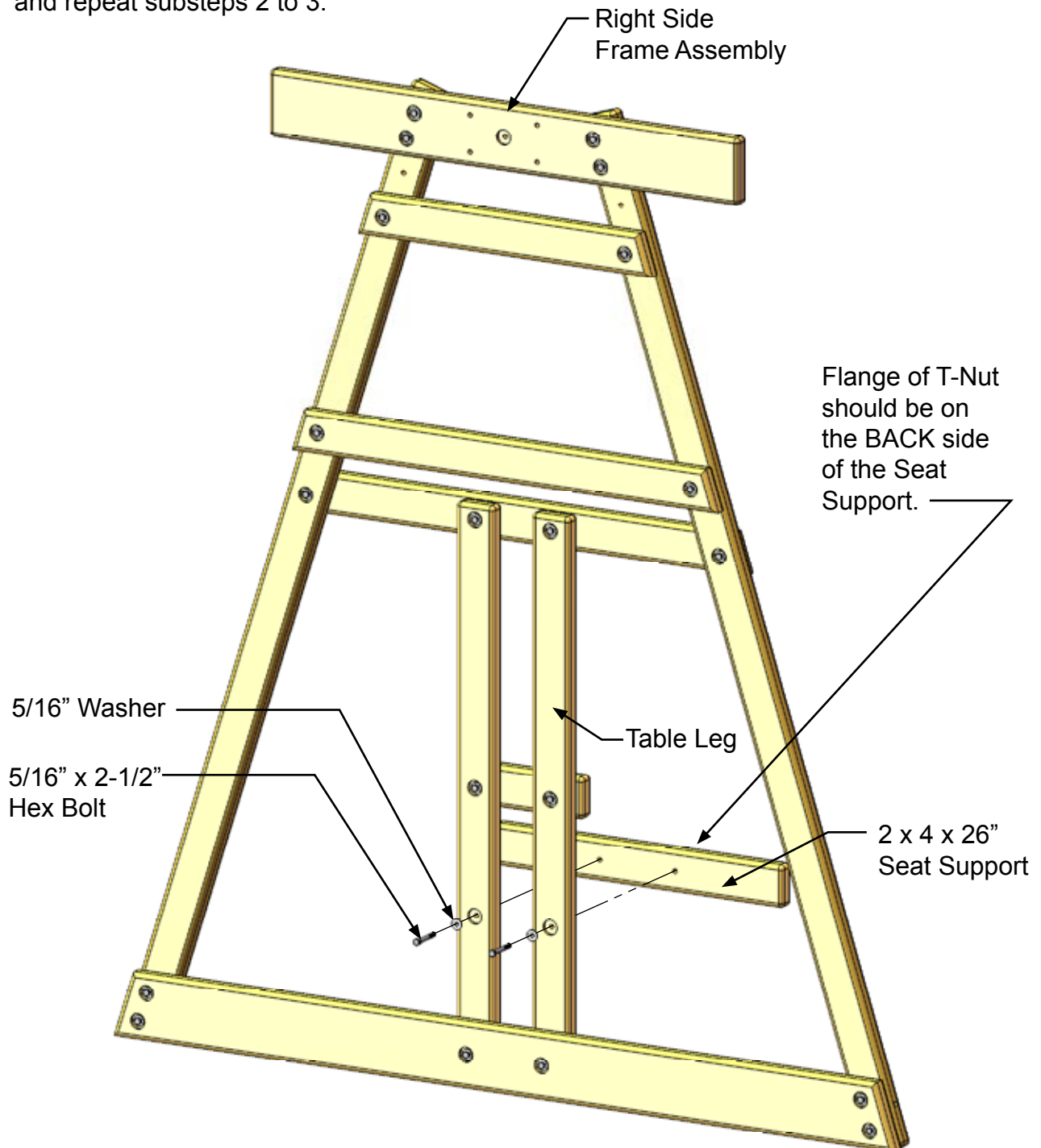

## Step 13A: Leveling the Side Frame Assemblies

- 1: At this point you may have noticed that the 2 x 6 x 42" Side Tarp Support at the top appears crooked. This step will fix that. Have an assistant help hold the frame assembly while you level and tighten the bolts in the substeps that follow.
- 2: First, place a level on top of the 2 x 6 x 70 Bottom Panel Board. This board must be level before proceeding.
- 3: Second, "loosen" but do not remove all the bolts which attach the horizontal boards to the corner posts. Also loosen but do not remove all the bolts in the Table Legs.
- 4: Third, place a level on top of the 2 x 6 x 42 Side Tarp Support and make this board level. You may have to shift the Side Tarp Support left or right as well as up or down to level it. Once the board is level tighten the bolts which secure it to the corner posts.
- 5: Now go to the 2 x 6 x 70 Bottom Panel Board and tighten the bolts that secure it to the corner posts.
- 6: For each remaining horizontal board place a level on top, level the board and finally tighten the bolts that connect the board to the corner posts.
- 7: Level the Seat/Table Supports and tighten the bolts in the Table Legs.
- 8: Repeat this process for the other side frame assembly.

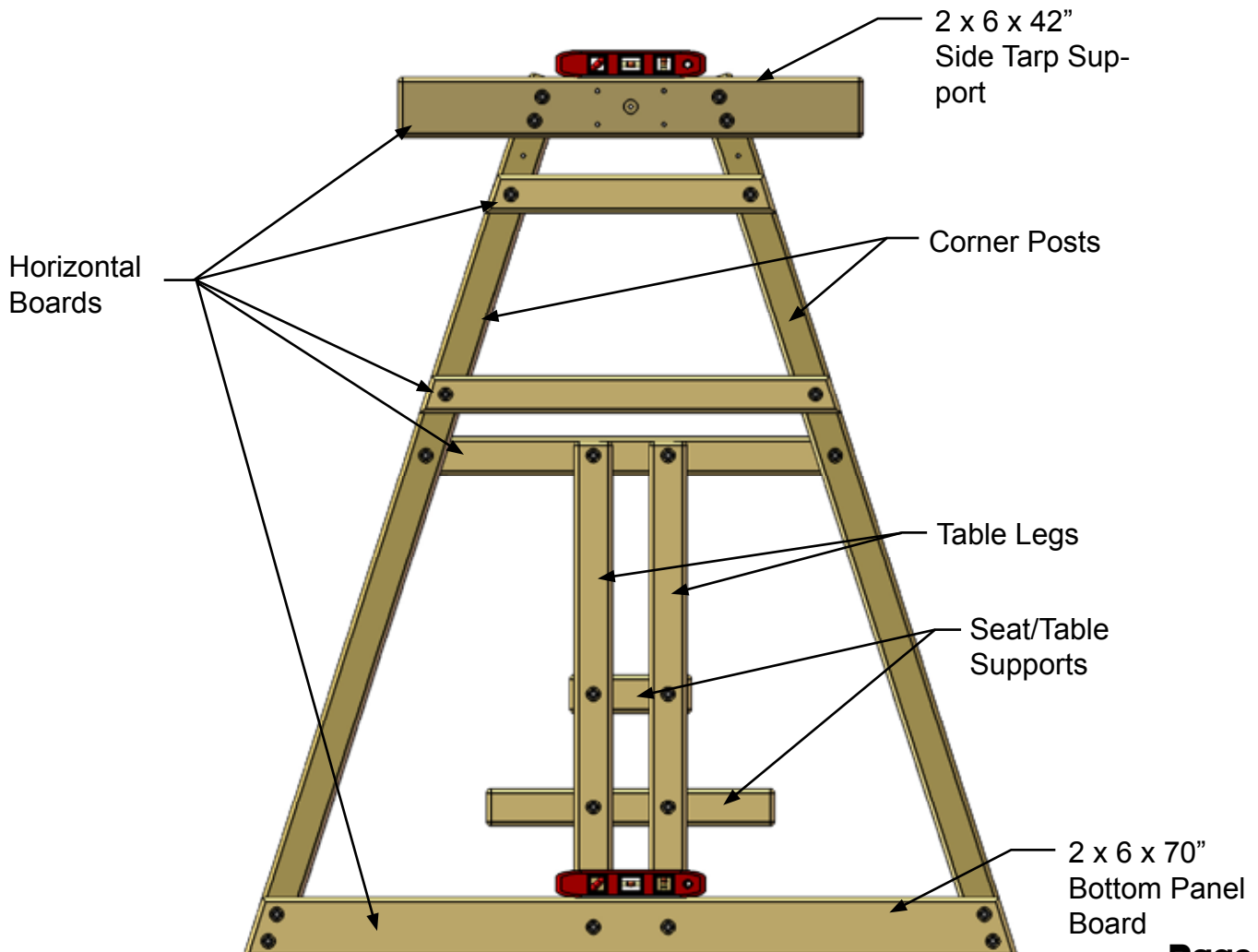

## Step 14: Front - Rear Panel Boards and Deck Spacers

- 1: Have an assistant hold up the Right Side Frame and Left Side Frame assemblies.
- 2: The flange of the T-nuts should be on the BACK side of the corner posts where the bottom boards are attached. (See Detail B)
- 3: Attach two 2 x 6 x 29-1/2" Front - Rear Panel Board to the corner posts with 5/16" x 4-1/2" hex bolts and 5/16" washers. Square the Front - Rear Panel Board to the corner posts and install the #8 x 2-1/2" Wood Screws into the predrilled holes.
- 4: Attach two 5/4 x 5 x 24" Deck Spacers to the Deck Supports with four #8 x 2" wood screws each. The *end* of the Deck Spacer should be flush to the inside surface of the corner post and the *side* of the Deck Spacer should be flush to the outside of the corner post. (See Detail A)

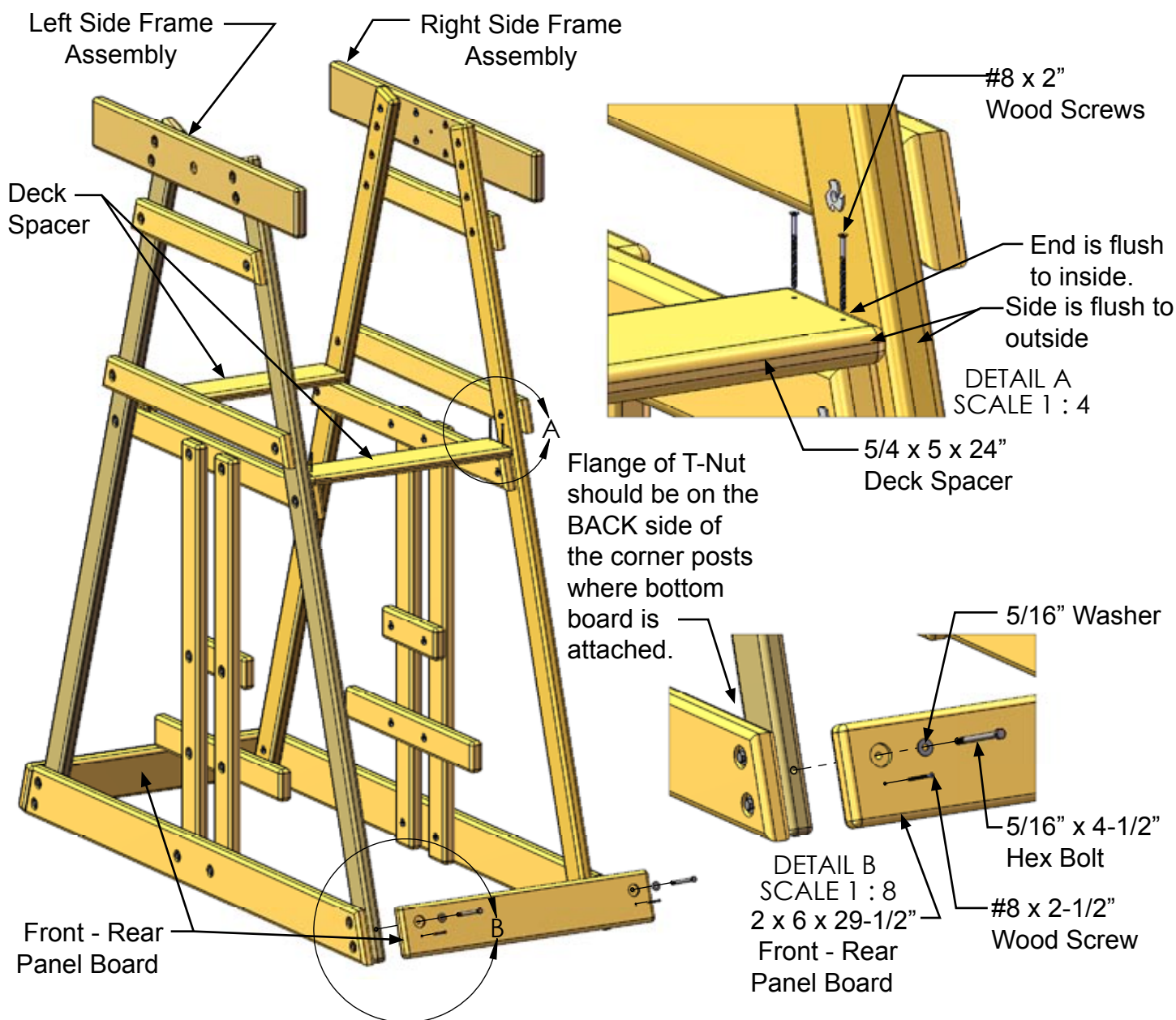

## Step 15: Diagonal Brace

- 1: Now is the time to level and square up your play set. Refer to the directions at the beginning of the manual for this process. Also see Step 29 for placement instructions.
- 2: Once you have the play set level and square proceed to substep 3.
- 3: Place the *bottom surface* of the 2 x 4 x 47-3/16" Diagonal Brace flush against the top of the Front - Rear Panel Board. Each *end surface* should be flush to the side of the corner posts.
- 4: Attach the Diagonal Brace to the Corner Posts with four #8 x 3" wood screws.

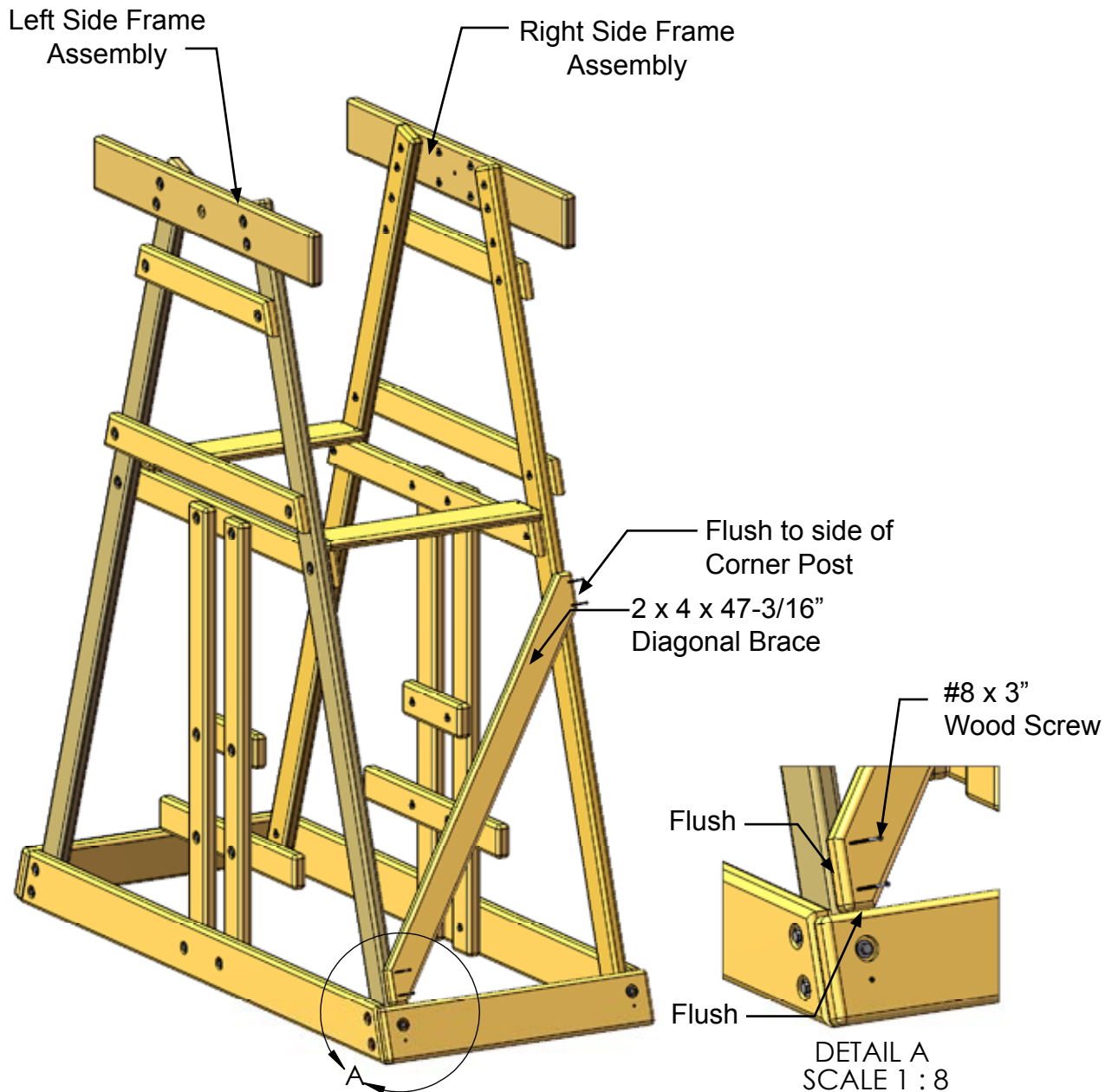

## Step 16: Deck Panel Board

1: Place the 5/4 x 5-1/2 x 26-3/4" Deck Panel Board on top of the Diagonal Brace. The ends of the Deck Panel Board should be flush to the corner posts. The Deck Panel Board should be square to the corner posts.

2: Attach the Deck Panel Board to the corner posts with #8 x 2-1/2" wood screws.

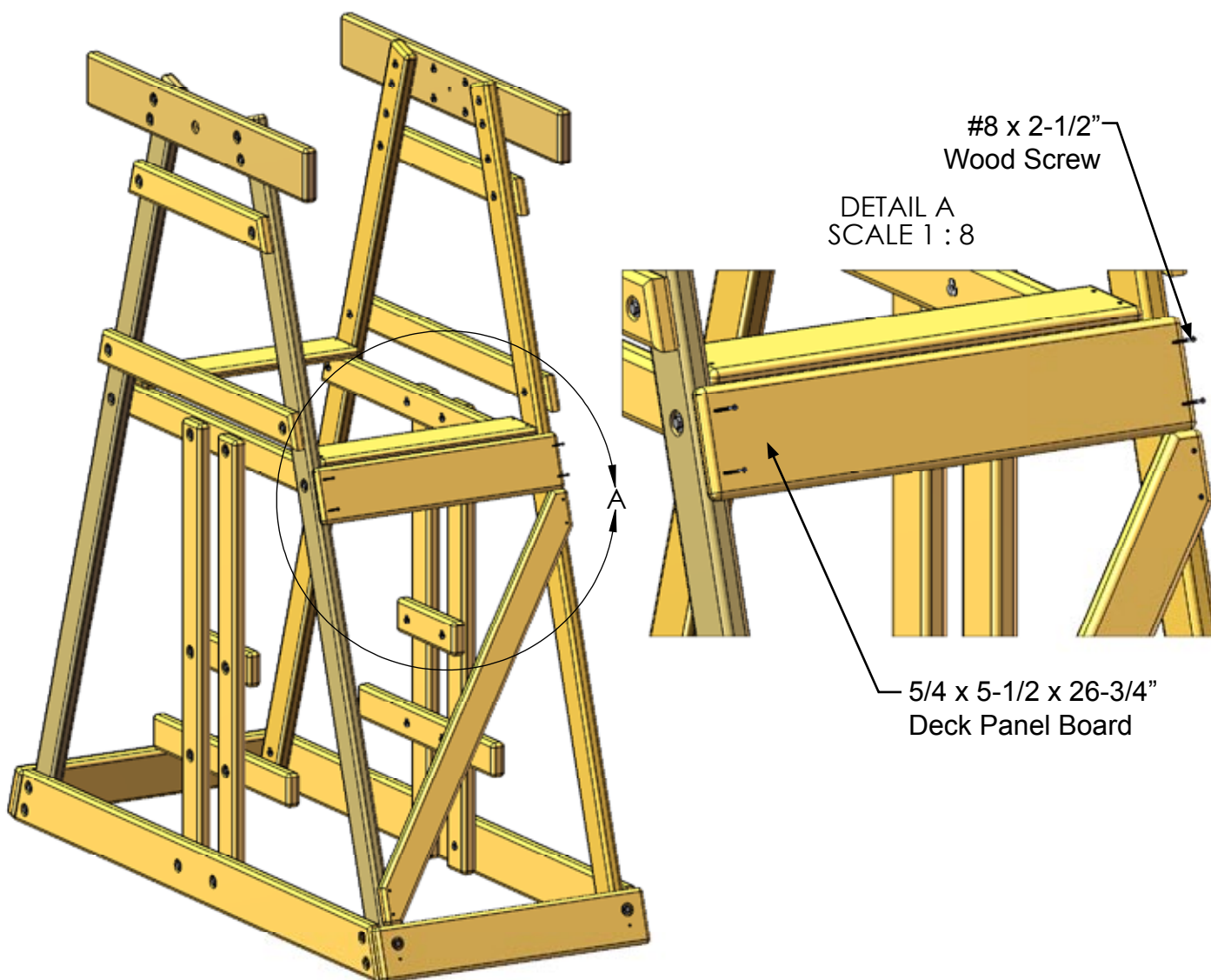

## Step 17: Rock Wall Boards

- 1: Space the bottom  $5/4 \times 5-1/2 \times 26-3/4$ " Rock Wall Board  $3-5/16$ " off the Front - Rear Panel Board as shown.
- 2: Attach the Rock Wall Board to the corner posts with four #8 x 2" Wood Screws.
- 3: Place another Rock Wall Board above the bottom Rock Wall Board leaving a  $3-1/4$ " gap. Attach the Rock Wall Board to the corner posts with four #8 x 2" Wood Screws.
- 4: Repeat this process for the remaining three Rock Wall Boards leaving a  $3-1/4$ " space between them.

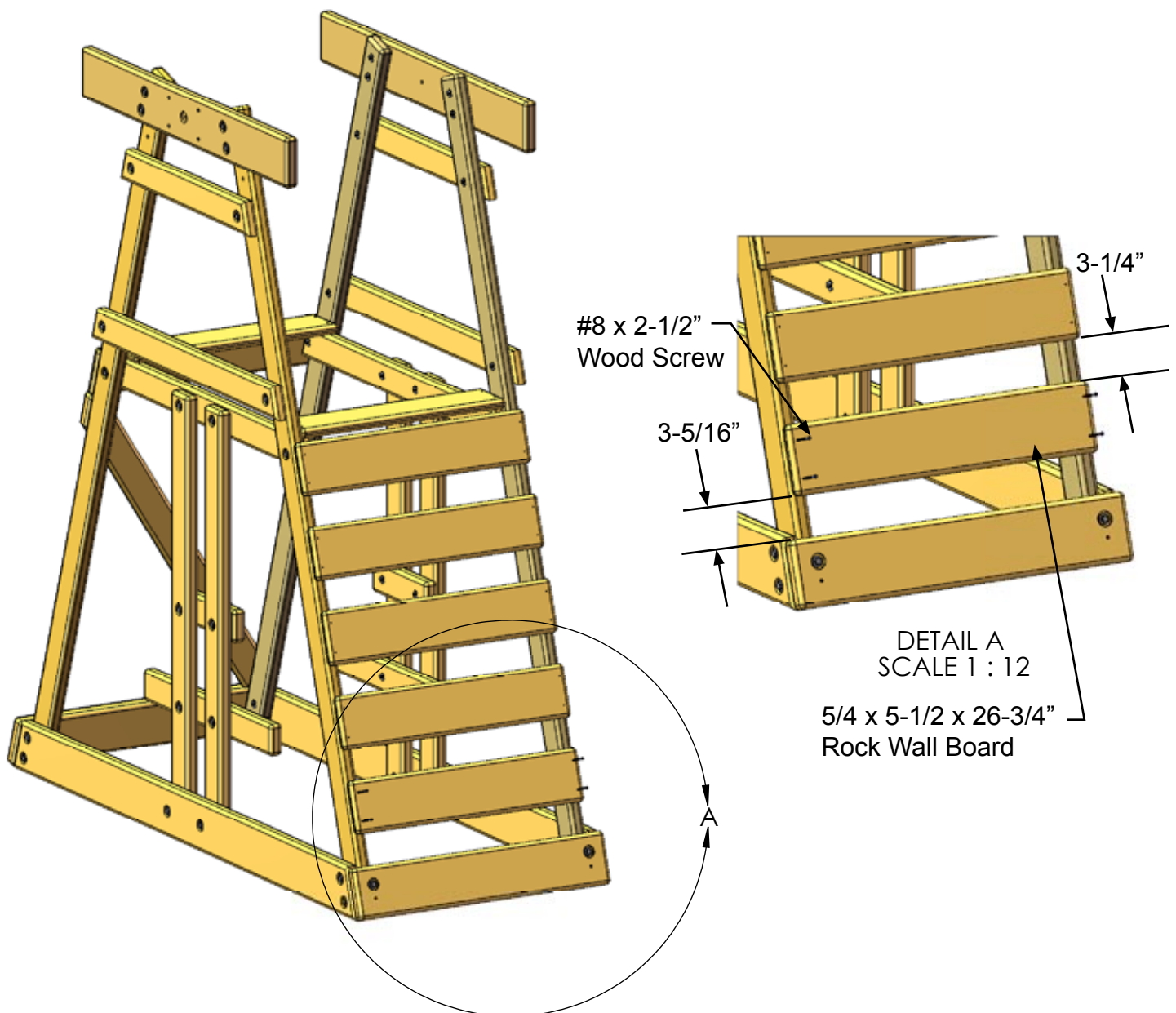

## Step 18: Seat and Table Boards

1: Place two  $5/4 \times 5-3/8 \times 24$ " Table Boards on top of the Table Supports. Attach each Table Board to the Table Support with #8 x 2" wood screws.

2: Place one  $5/4 \times 5-3/8 \times 24$ " Seat Board on top of the Seat Supports at each end. Attach each Seat Board to the Seat Supports with #8 x 2" wood screws.

Note: Some boards have been removed from the pictures for clarity

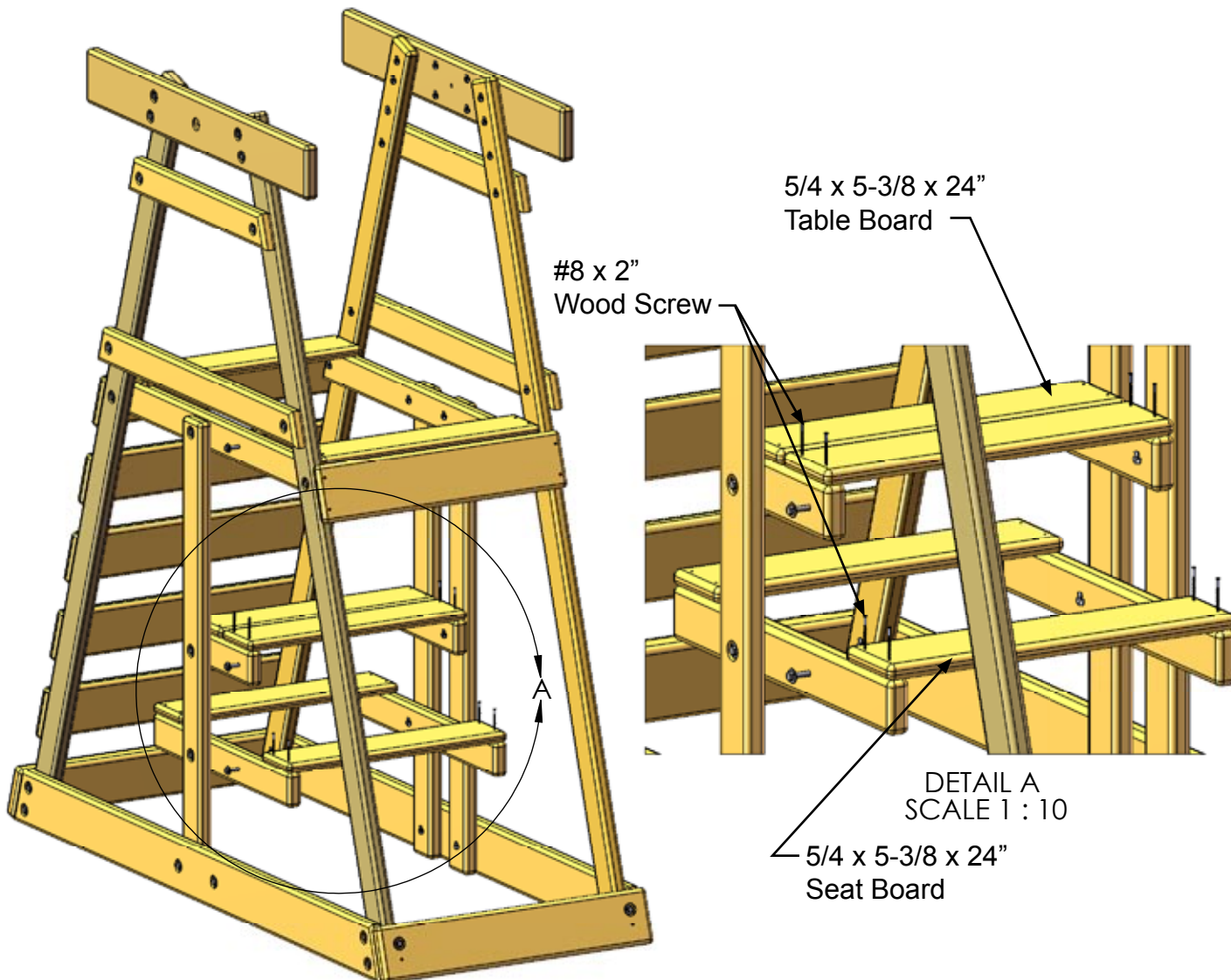

## Step 19: Deck Boards

1: Place five 5/4 x 5-3/8 x 29" Deck Boards on top of the Deck Supports as shown below. Leave an equal space between all the Deck Boards and Deck Spacers. Line up the holes in the Deck Boards along the center of the Deck Supports. Each Deck Board will overlap the side of the Deck Supports by about 2-1/2" on each side.

2: Attach each Deck Board to the Deck Supports with #8 x 2" wood screws.

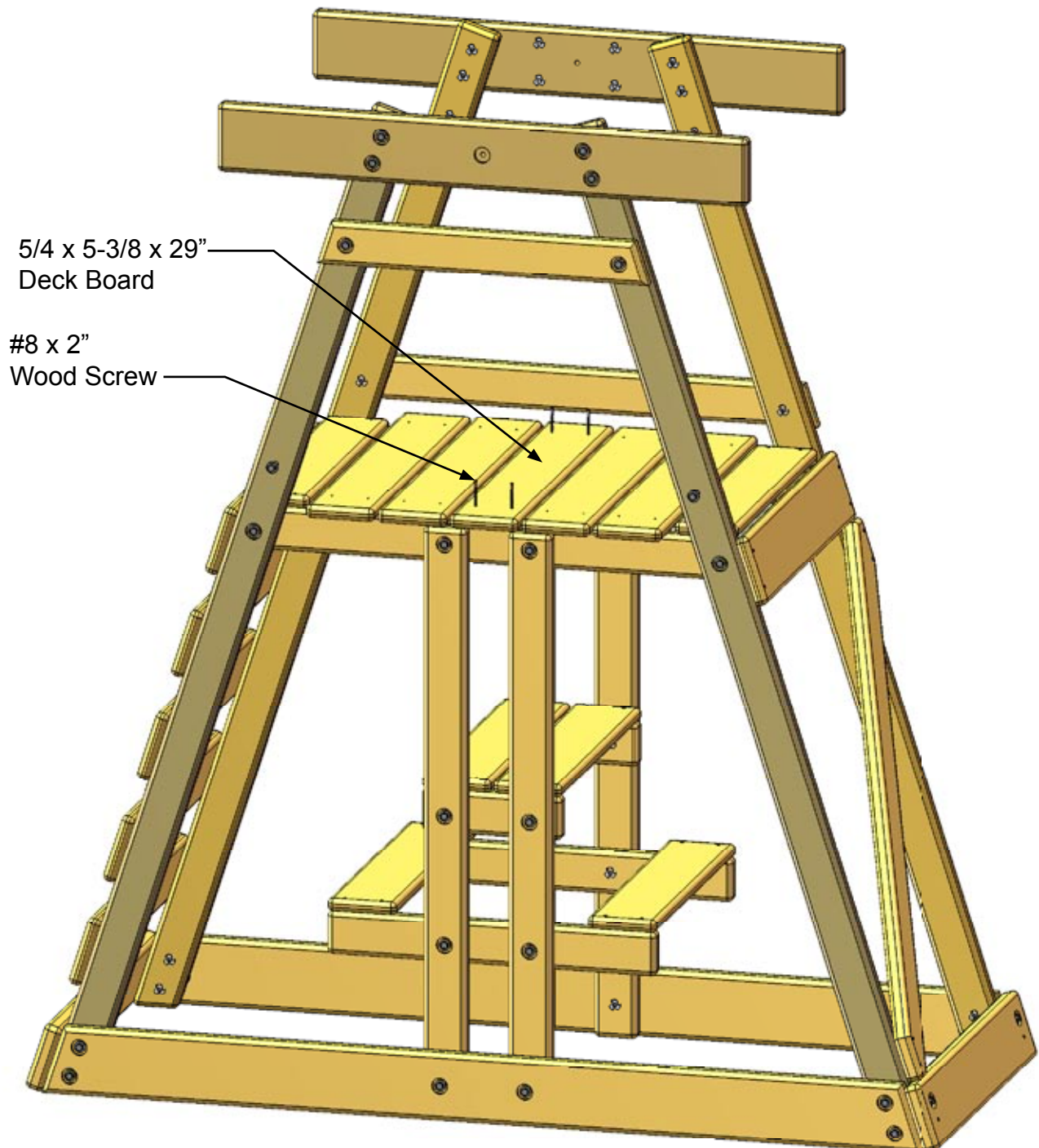

## Step 20: Panel Slats

- 1: Attach one  $5/4 \times 2-5/8 \times 20-1/4$ " Panel Slat to the inside of the Upper and Lower Slat Boards in the center. Attach it with two #8 x 2" wood screws.
- 2: Arrange two Panel Slats on either side of the center Panel Slat as shown in the top picture below. Attach each Panel Slat with #8 x 2" wood screws.
- 3: Repeat substeps 1 and 2 for the right side.

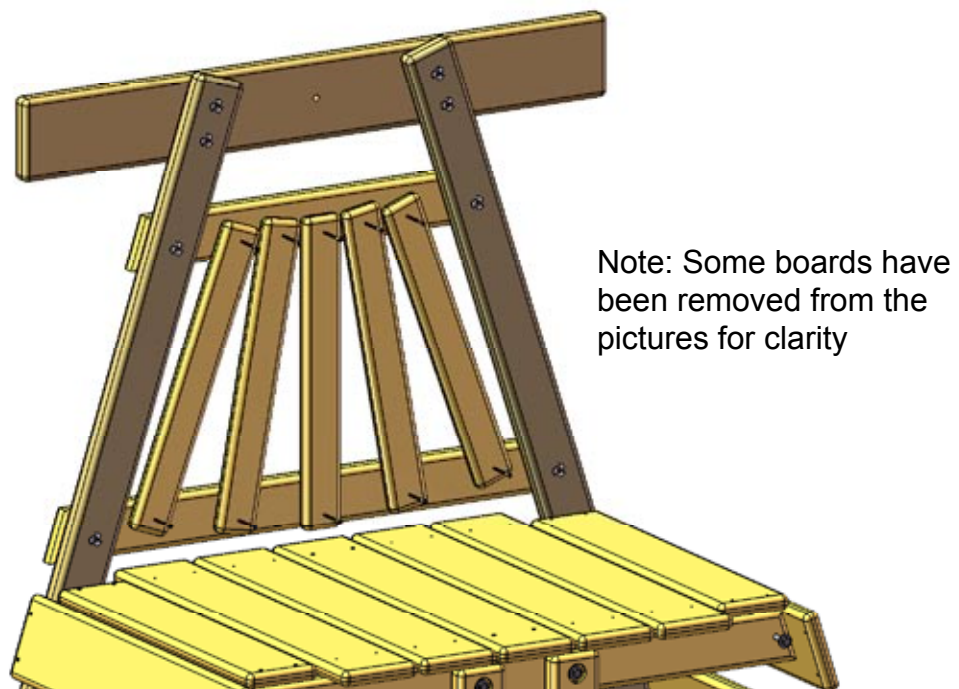
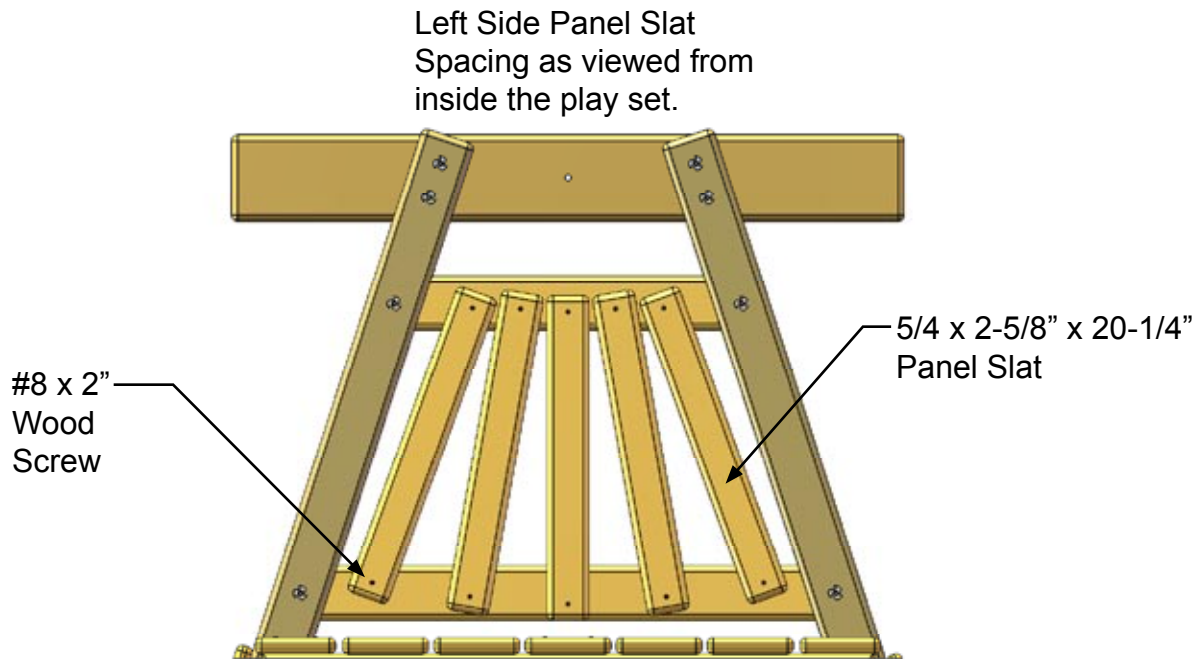

### Step 21: Center Tarp Supports

1: Hammer a T-Nut into the 2 x 4 x 24-1/2" Center Tarp Support. (See Detail A) Attach the Center Tarp Support to the Side Tarp Support with a 5/16" x 2-1/2" hex bolt and a 5/16" washer. Square the Center Tarp Support to the Side Tarp Support and attach it with two #8 x 2-1/2" wood screws.

2: Repeat substep 1 for the other side.

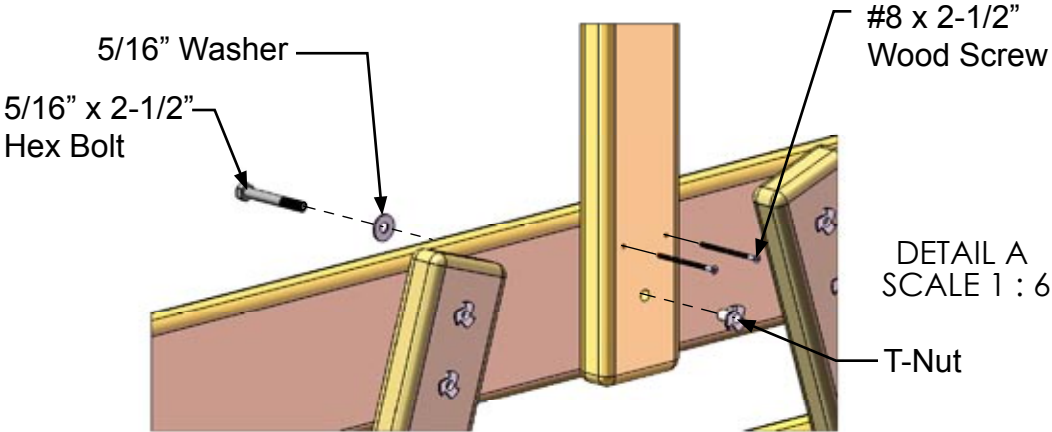
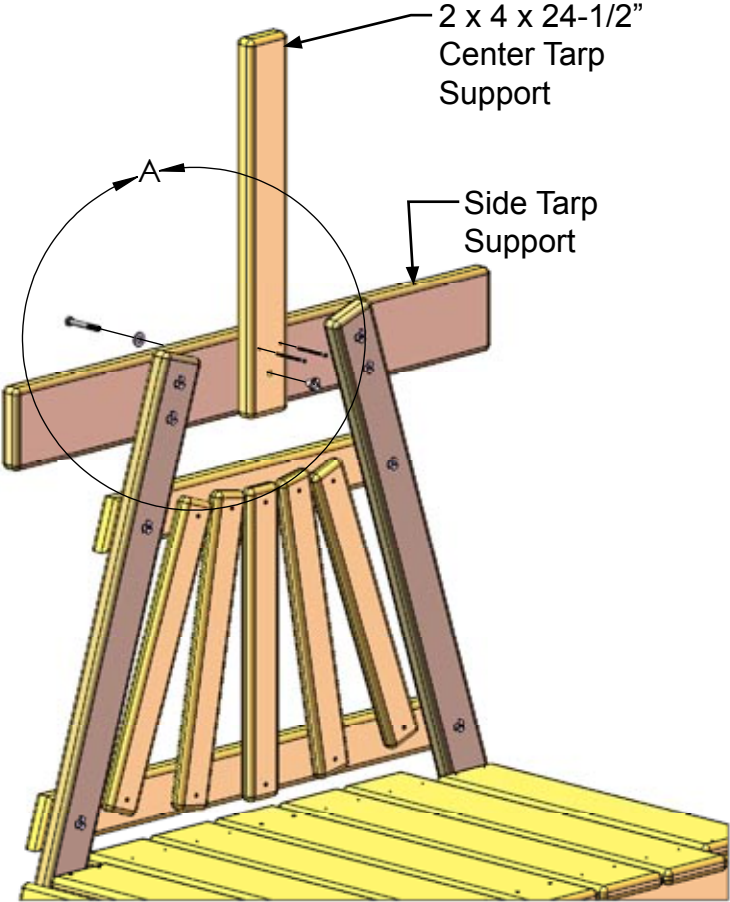

## Step 22: Top Tarp Board and End Tarp Boards

1: Place the 2 x 4 x 26-3/4" Center Tarp Board on the top of the Center Tarp Supports boards that were just installed. Attach the Center Tarp Board to the Center Tarp supports with four #8 x 2-1/2" wood screws.

2: Place the 2 x 6 x 29-1/2" End Tarp Boards on the end of the Side Tarp Supports. Attach each End Tarp Board to the Side Tarp Supports with four #8 x 2-1/2" wood screws.

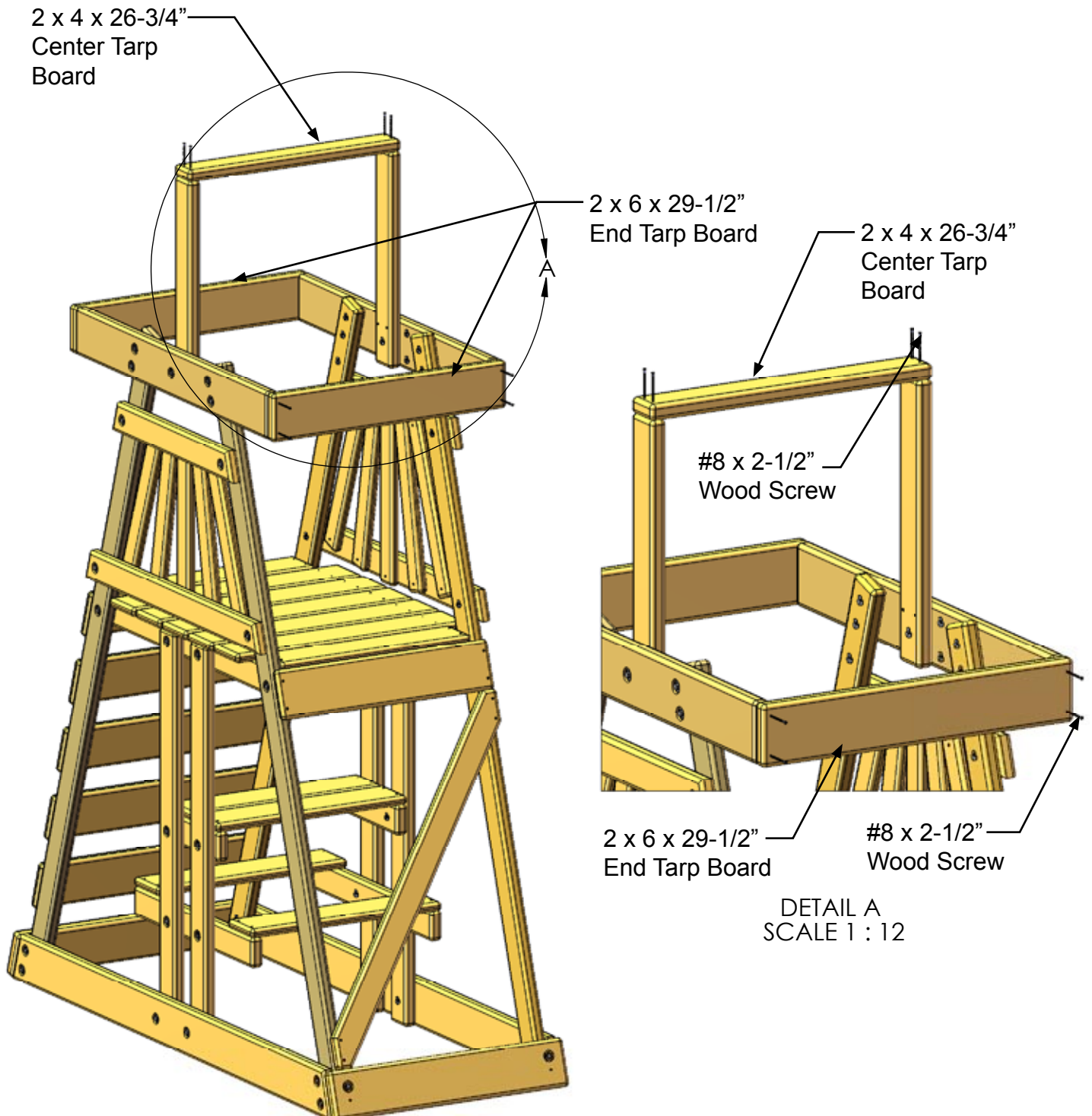

## Step 23: Tarp

- 1: Place the 26-3/4" x 65-3/4" Tarp over the top of the Center Tarp Board.
- 2: The ends of the Tarp should overlap the End Tarp Boards equally on the front and rear.
- 3: Attach the Tarp to the End Tarp Boards through the grommets with six #14 x 1-1/4" Pan Head Screws and six 1/4" flat washers.



## Step 24: Swing Beam Support

1: Place the 4 x 4 x 24" Swing Beam Support against the outside of the right corner posts.

2: Attach the Swing Beam Support to the corner posts with 5/16" x 3-1/2" hex bolts and 5/16" washers into the t-nuts that were previously installed.

Note the flange of the T-nuts should be on the BACK side of the corner posts where the support is attached.

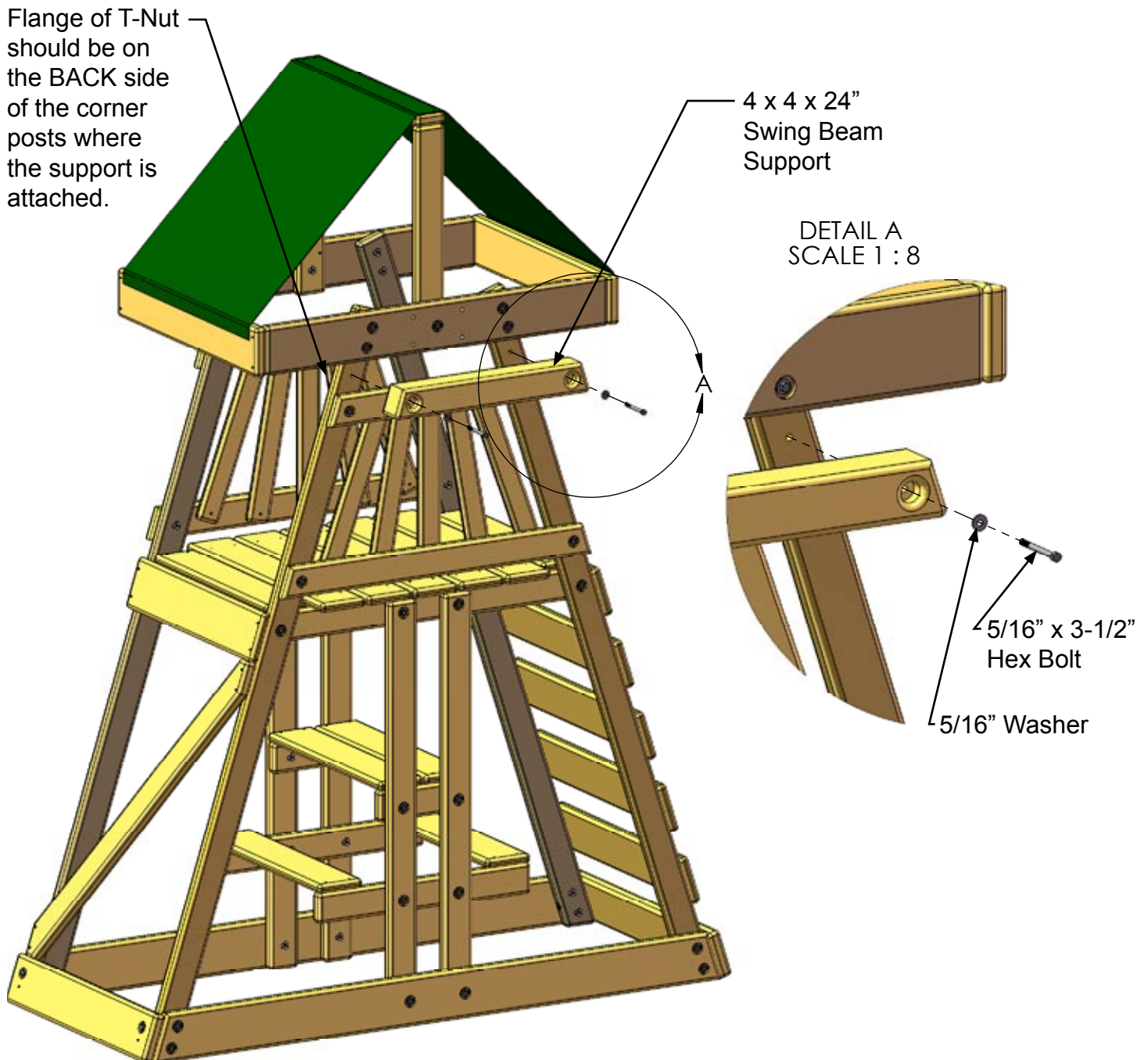

## Step 25: Mini Iron Ductile Swing Hangers

1: Attach each Mini Iron Ductile Swing Hanger to the 4 x 6 x 96" Swing Beam with 3/8" x 7" carriage bolts and torque washers on top and 3/8" washers with 3/8" lock nuts on the bottom.

2: Cover the exposed threads on the end of the carriage bolts with the 3/8" vinyl bolt caps.

Note you will have two sizes of vinyl bolt caps in your hardware; the smaller diameter ones are for 5/16" bolts and the larger diameter ones are for 3/8" bolts.

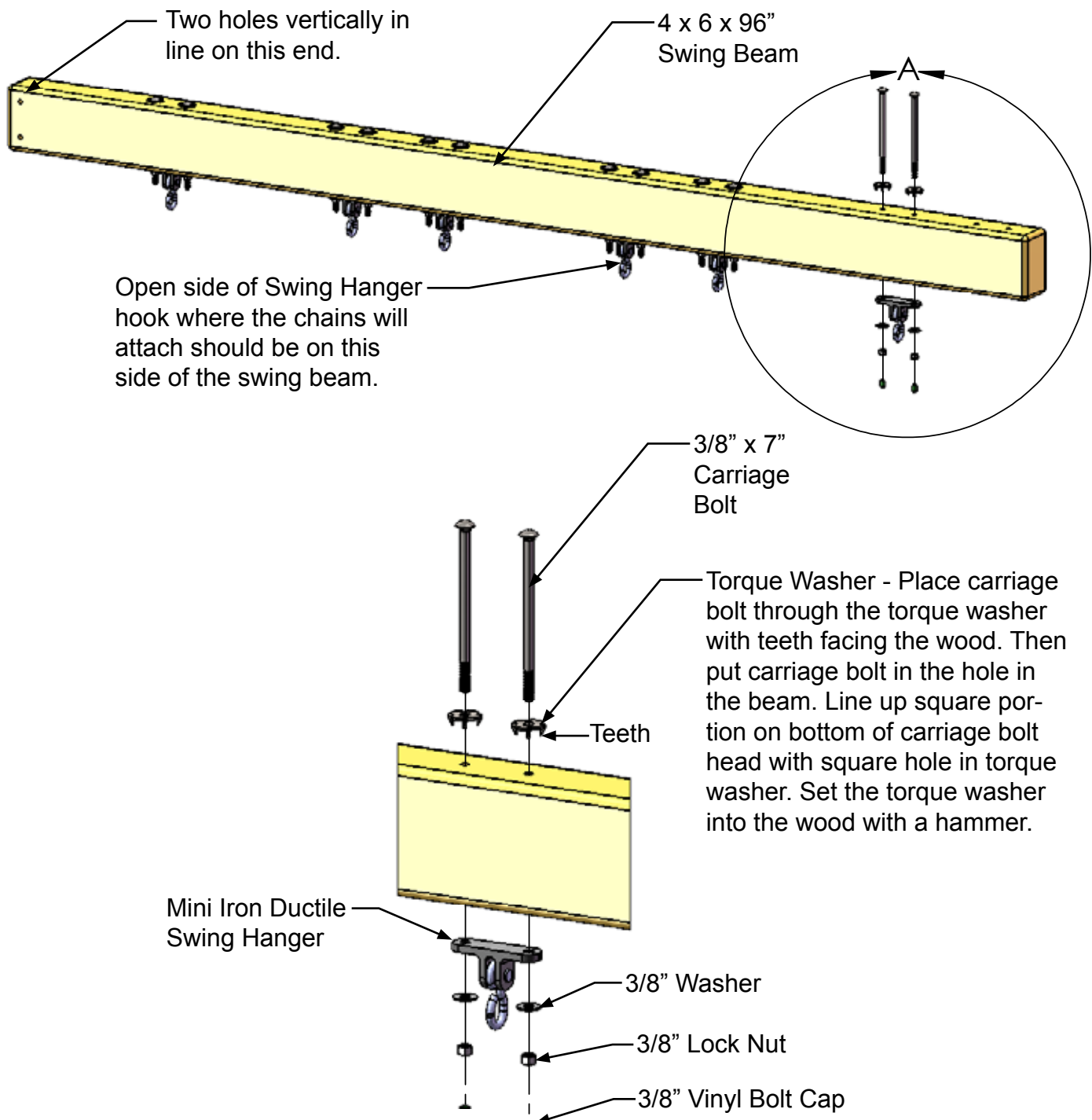

## Step 26: Swing Leg Bracket and Swing Leg Angle Bracket

1: First, attach the Swing Leg Bracket to the swing beam with the 3/8" x 6-1/2" carriage bolt and torque washer on top and a 3/8" washer, 3/8" lock nut and 3/8" bolt cap on bottom.

2: Second, attach the Swing Leg Angle Bracket to the Swing Leg Bracket with a 3/8" x 7" carriage bolt and torque washer on top and a 3/8" washer, 3/8" lock nut and 3/8" bolt cap on bottom.

3: Third, attach the Swing Leg Angle Bracket to the Swing leg Bracket with a 5/16" x 1" hex bolt, two 5/16" washers, 5/16" lock nut and 5/16" bolt cap.

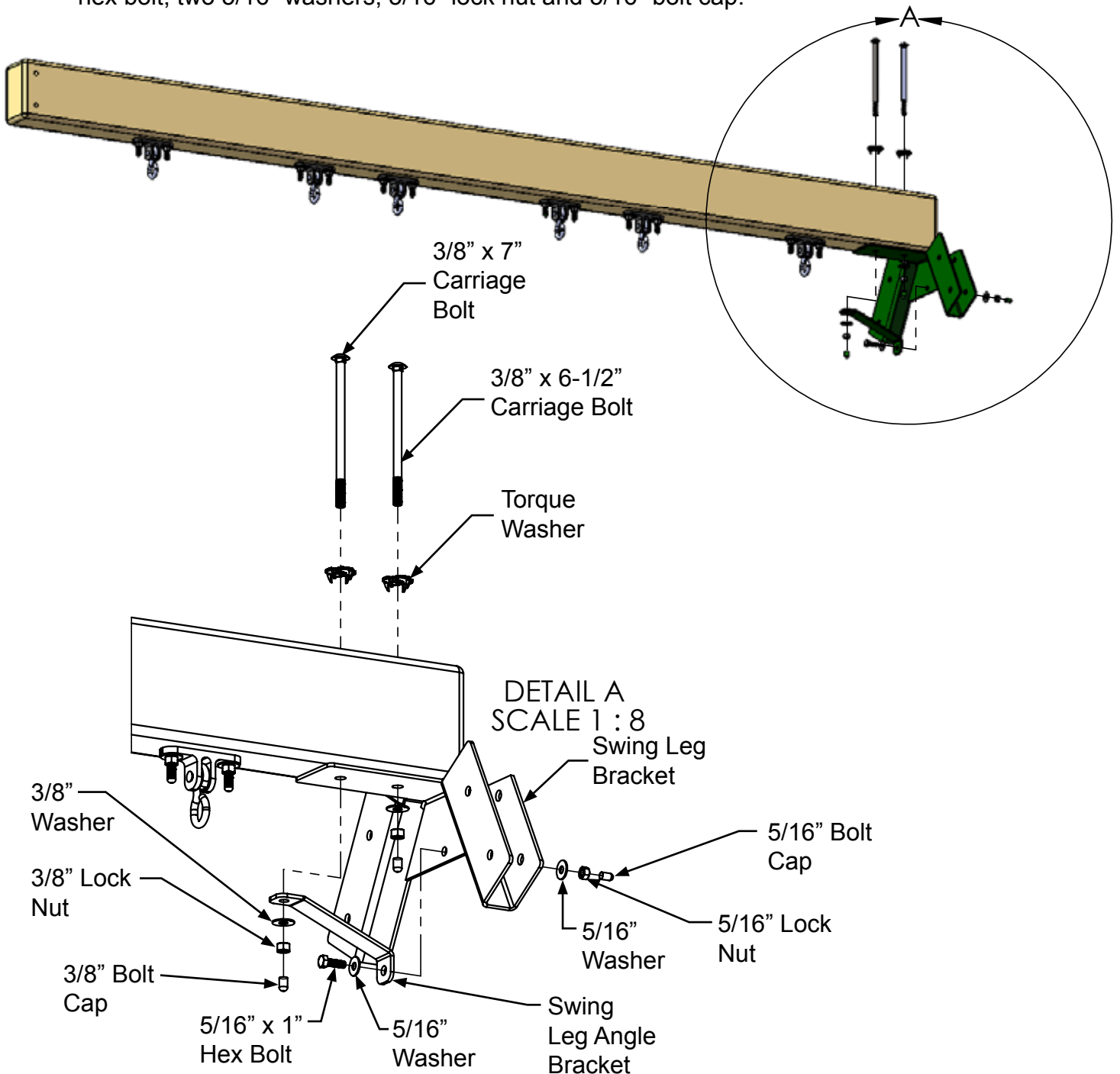

## Step 27: Swing Legs

- 1: Place the end of the 2 x 4 x 86" Swing Leg with two holes in it inside the "u" shaped channel in the Swing Leg Bracket. Line up the holes in the leg with the holes in the bracket.
- 2: Attach the Swing Leg to the Swing Leg Bracket with two 5/16" x 2-1/2" hex bolts, four 5/16" washers, two 5/16" lock nuts and two 5/16" bolt caps. Leave the lock nuts a little loose until the next step.
- 3: Attach the other Swing Leg to the Swing Leg Bracket on the other side in the same manner. Leave the lock nuts a little loose until the next step.

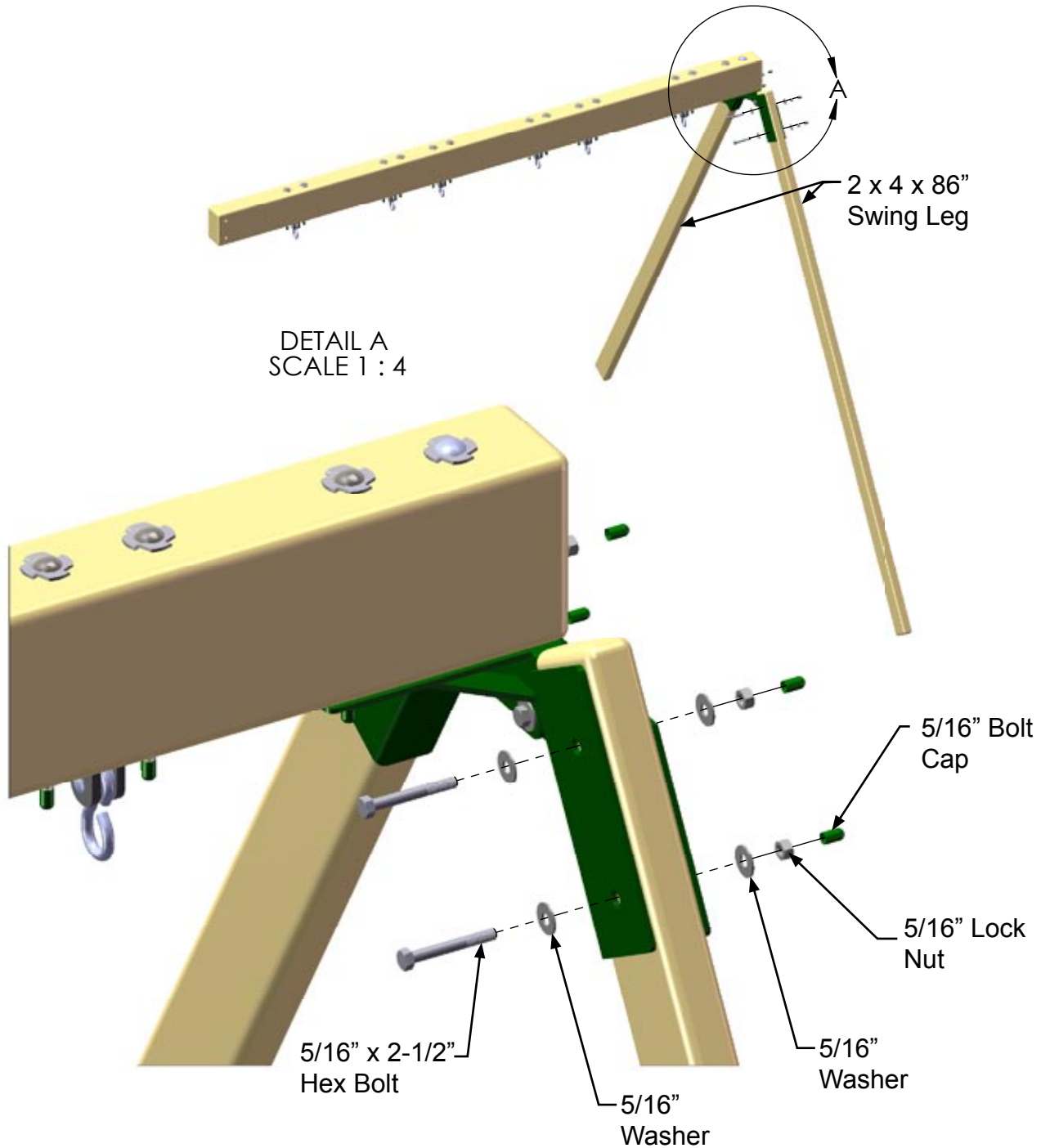

## Step 28: Swing Leg Crossmember

- 1: Hammer a t-nut into the bottom hole on the inside of each Swing Leg.
- 2: Attach the 2 x 4 x 94" Swing Leg Crossmember to the outside of the Swing Legs with 5/16" x 2-3/4" hex bolts and 5/16" washers.
- 3: Now go back and tighten up the bolts at the top of the Swing Legs.

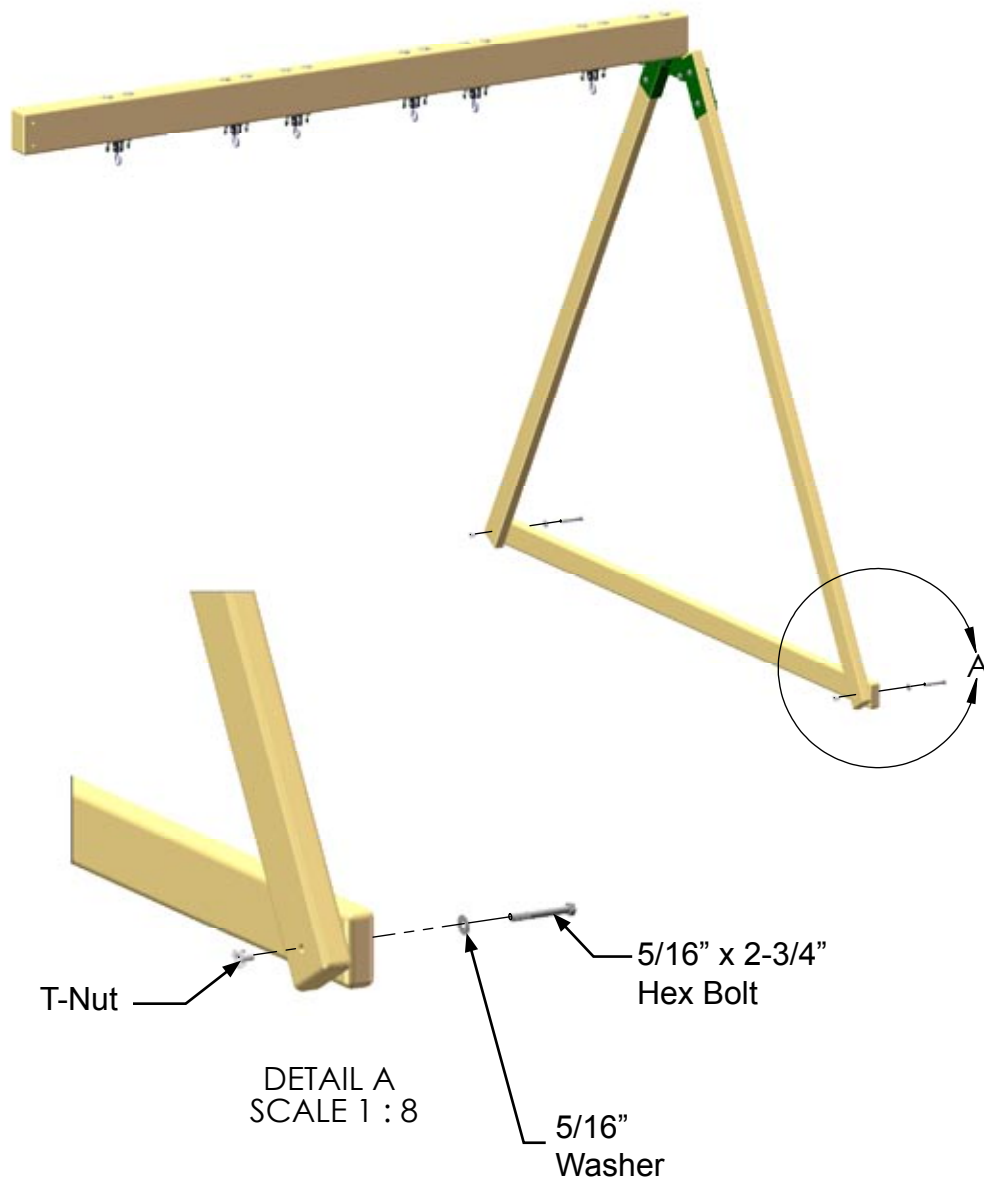

## Step 29: Placement of your Play Set

1: This play set is designed to be placed upon a relatively flat and level surface. If your yard is relatively flat and level where you are placing your play set then the Swing Leg Crossmember will sit flush to grade.

2: If your yard is "sloped" slightly then you should place your play set as shown below and "dig in" the Swing Legs. Afterwards go back and regrade the soil to level on both sides of the Swing Legs.

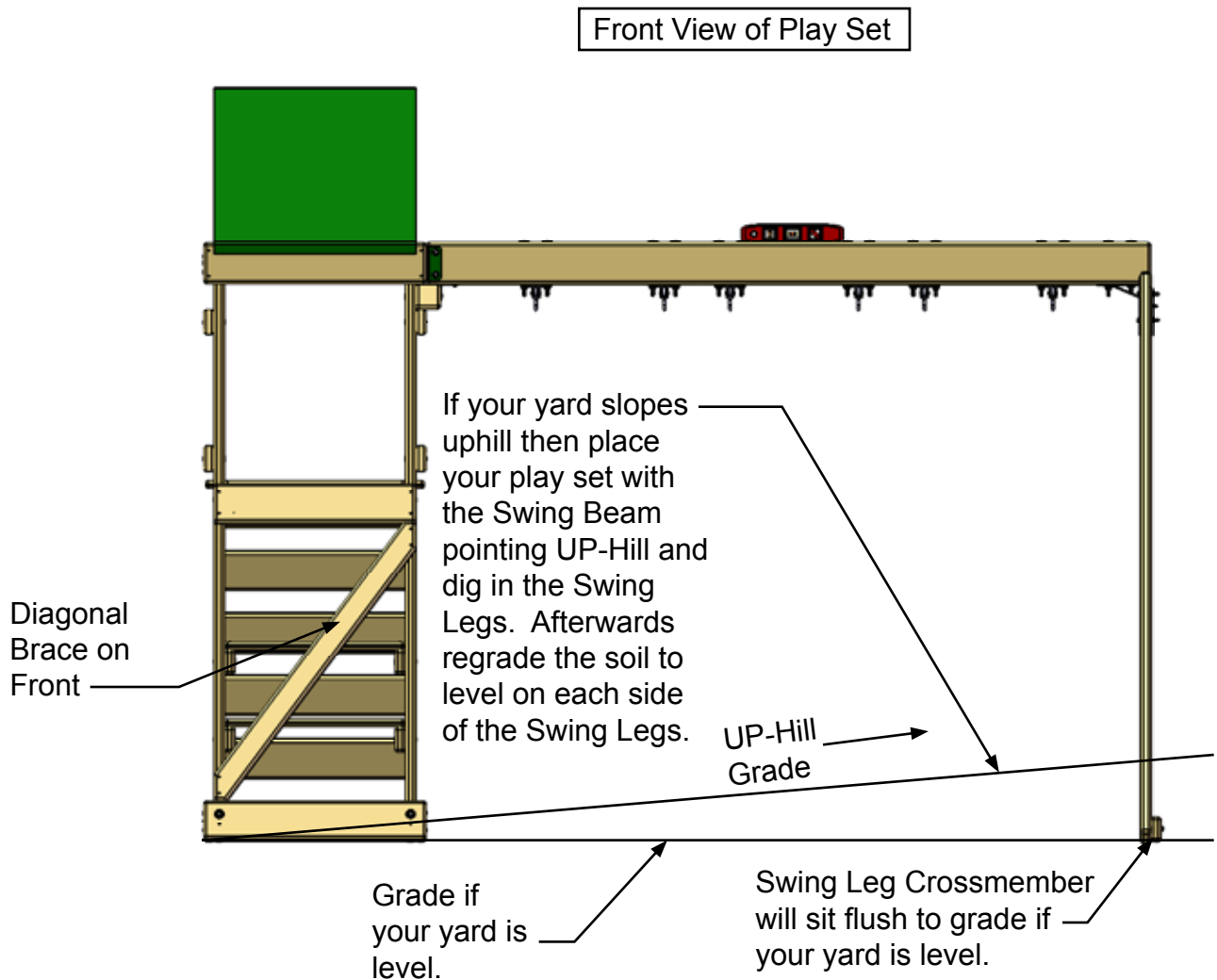

## Step 30: Attaching Swing Beam to Play Set

1: Place the Swing Beam on top of the 4 x 4 x 24" Swing Beam Support.

2: Check the Swing Beam for level. If the swing beam is level then proceed to substep 3.

If the swing beam is not level then use a shovel to mark around the Swing Leg Crossmember. Remove the Swing Beam from the 4 x 4 x 24" Swing Beam Support so it does not fall on you. Dig out the area that you marked until a depth is reached that will make the swing beam level. Place the Swing Beam back onto the Swing Beam Support and verify it is level. If it is not level then remove the Swing Beam from the Swing Beam Support and add or remove dirt from the dug out area until level is achieved.

3: Place one 2" x 2" x 4-1/2" Bracket on each side of the Swing Beam. Loosely attach each bracket to the 2 x 6 x 42" Side Tarp Support - Right with 5/16" x 1-1/2" hex bolts and 5/16" washers.

4: Loosely attach the Brackets to the Swing Beam with 5/16" x 4-1/2" hex bolts, 5/16" washers, 5/16" lock nuts and 5/16" bolt caps. **TIP:** Should you have trouble attaching the Brackets then "slightly" loosen the bolts that attach the 4 x 4 x 24" Swing Beam Support. This will allow the support to drop down slightly so that the bolts will go through the Brackets easier.

5: Tighten all the bolts.

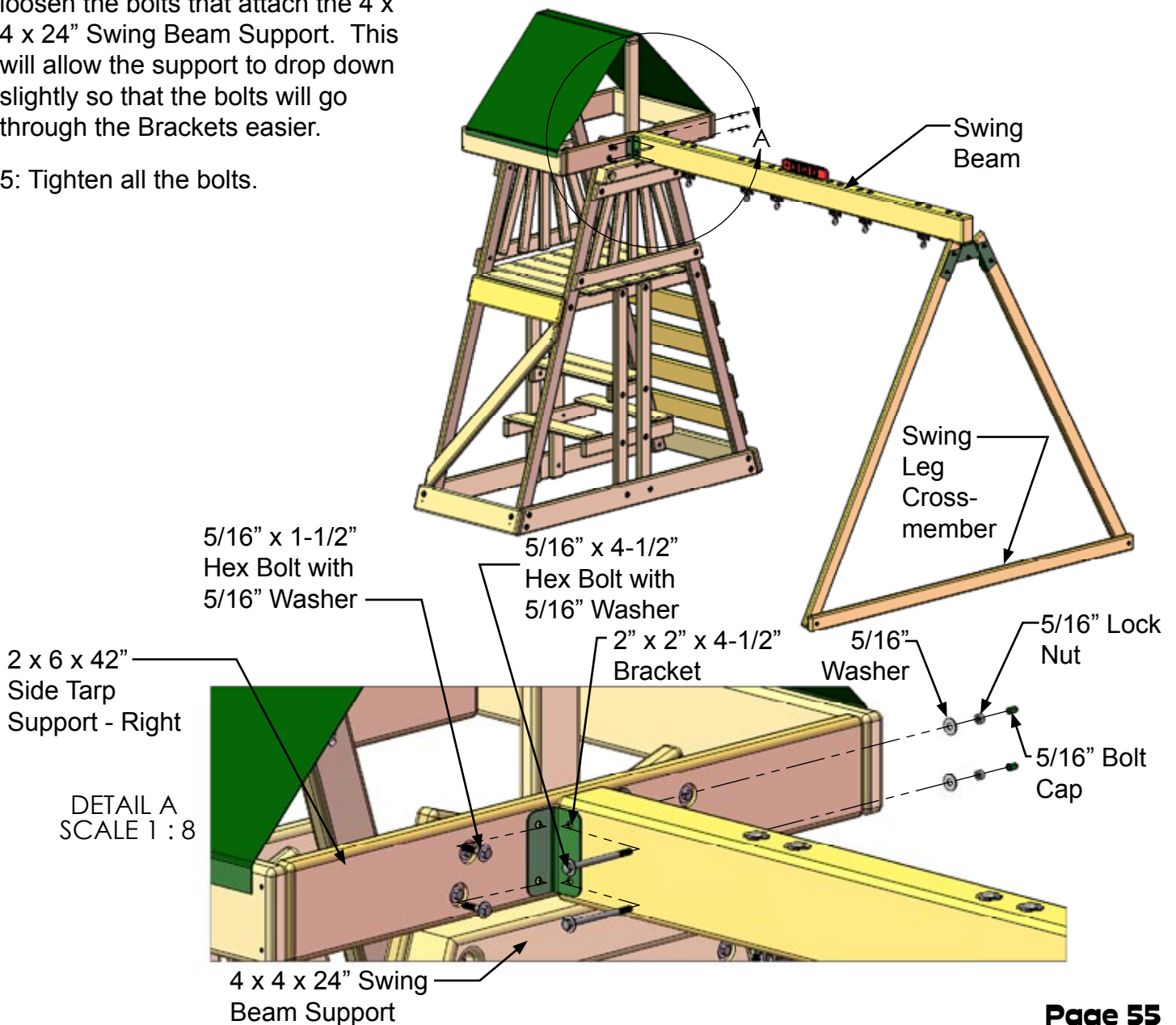

### Step 31: 90° Green Bracket

1: Place a 90° Green Bracket centered underneath the Swing Beam and against the Swing Beam Support.

2: Attach the 90° Green Bracket to the Swing Beam and Swing Beam Support with #14 x 1-1/4" pan head screws and 1/4" washers.

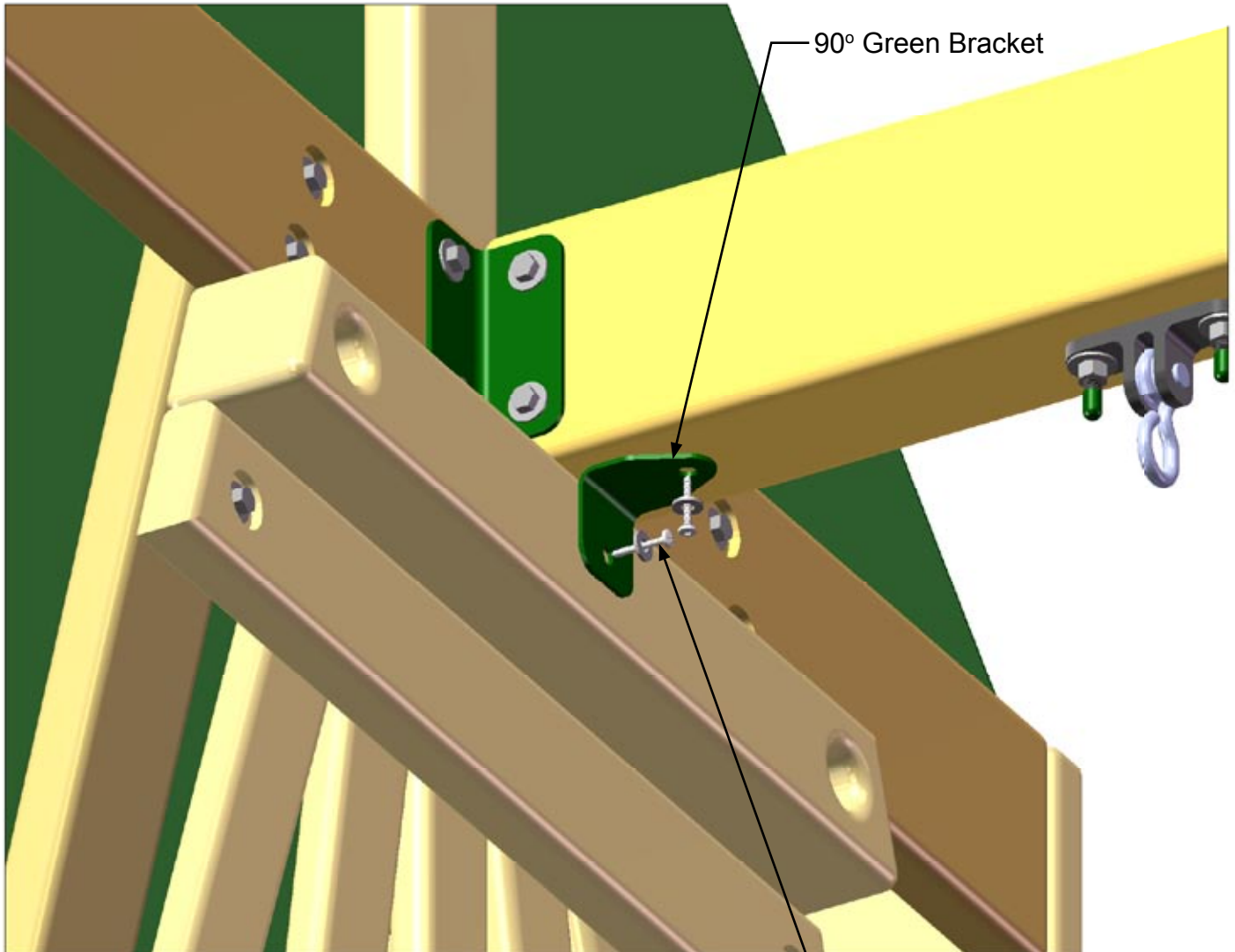

90° Green Bracket

#14 x 1-1/4" Pan Head  
Screw with 1/4" Washer

## Step 32: Wave Slide

- 1: Place the Wave Slide in the opening at the front of the play set.
- 2: The lip of the Wave Slide should sit on top of the Deck Spacer as shown.
- 3: Attach the Wave Slide to the deck with two #8 x 1-1/4" wood screws.  
**\* DO NOT OVER TIGHTEN \***
- 4: Once the slide is installed **DO NOT** lift the end of the slide. **DO NOT** bump the slide with a lawn mower. These actions and any other actions which crack the slide where the screws are fastened to the deck are not covered by your warranty.

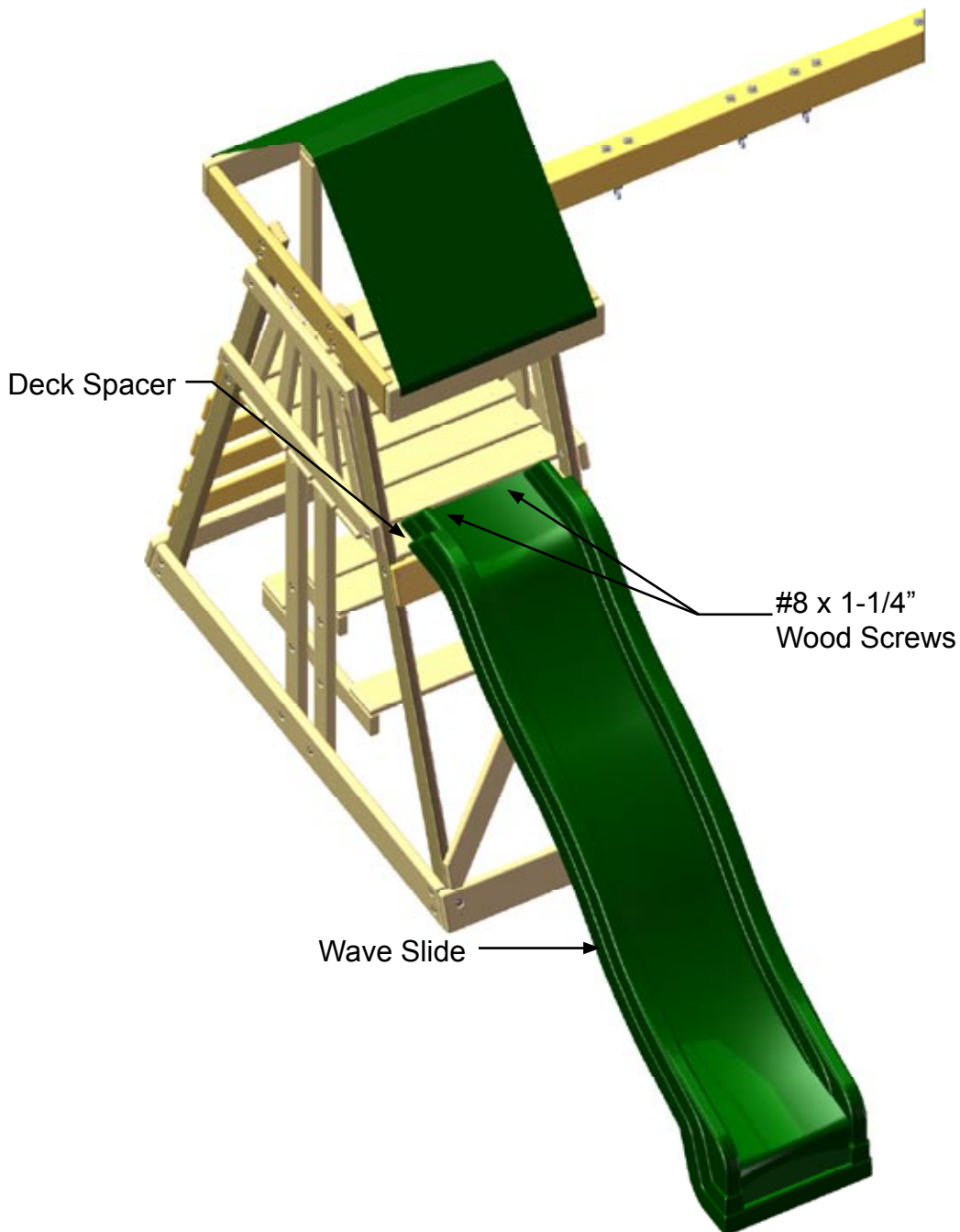

### Step 33: Telescope

- 1: Place one of the L-shaped Telescope Mounting Brackets on the Side Tarp Support - Left on the left side of the play set.
- 2: Attach the L-shaped bracket with two screws provided with the Telescope.
- 3: Place the base of the Telescope into the cut out area of the L-shaped bracket.
- 4: Attach another L-shaped Telescope Mounting Bracket directly across from the previously installed bracket and secure with the provided hardware.

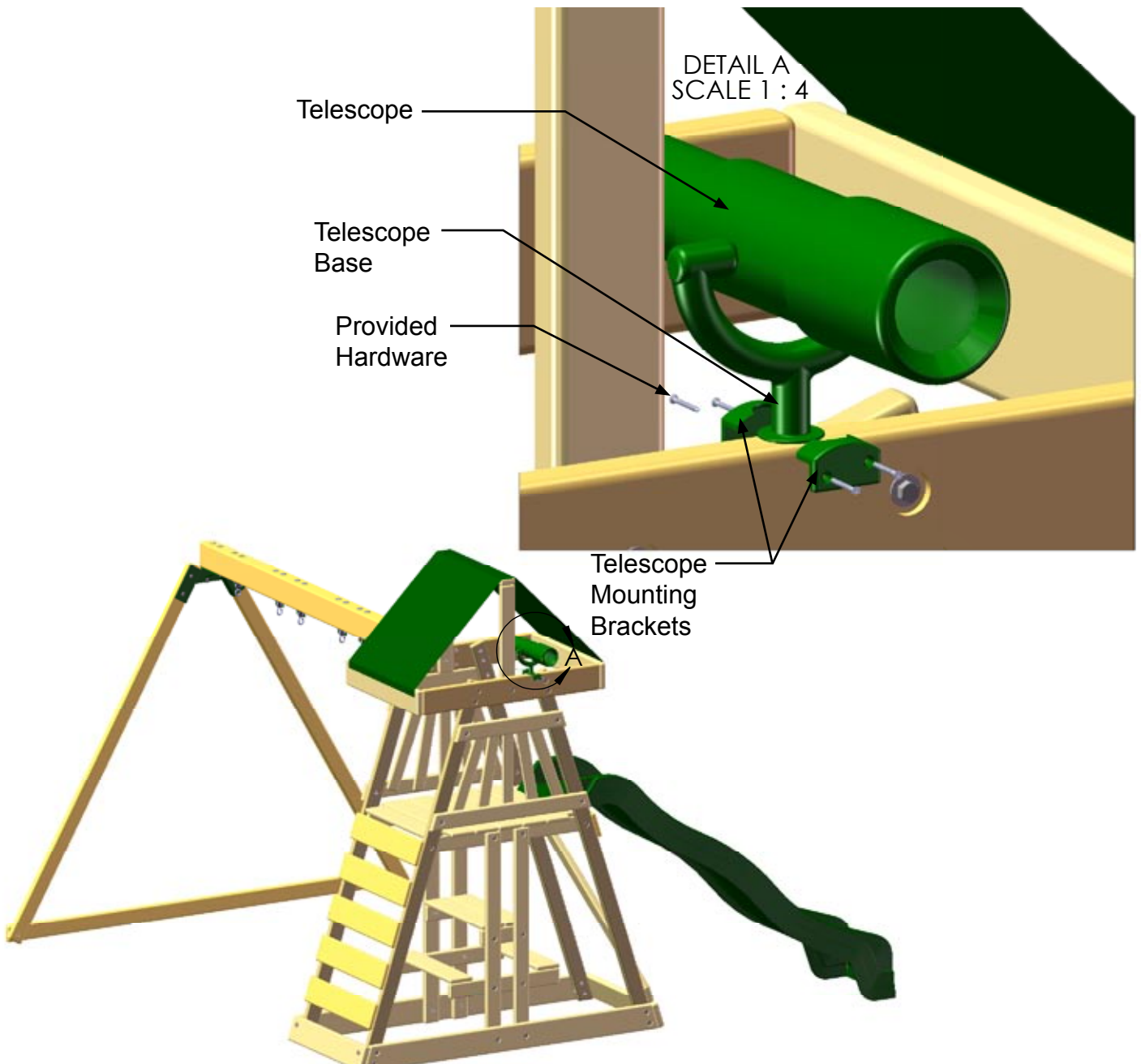

### Step 34: Safety Handles

- 1: Place the Safety Handles against the corner posts as shown above the Rock Wall boards.
- 2: Space the Safety Handles up or down to suit the needs of your child.
- 3: Attach each Safety Handle with two 1-1/4" phillips pan head screws and 1/4" washers provided with each Safety Handle.

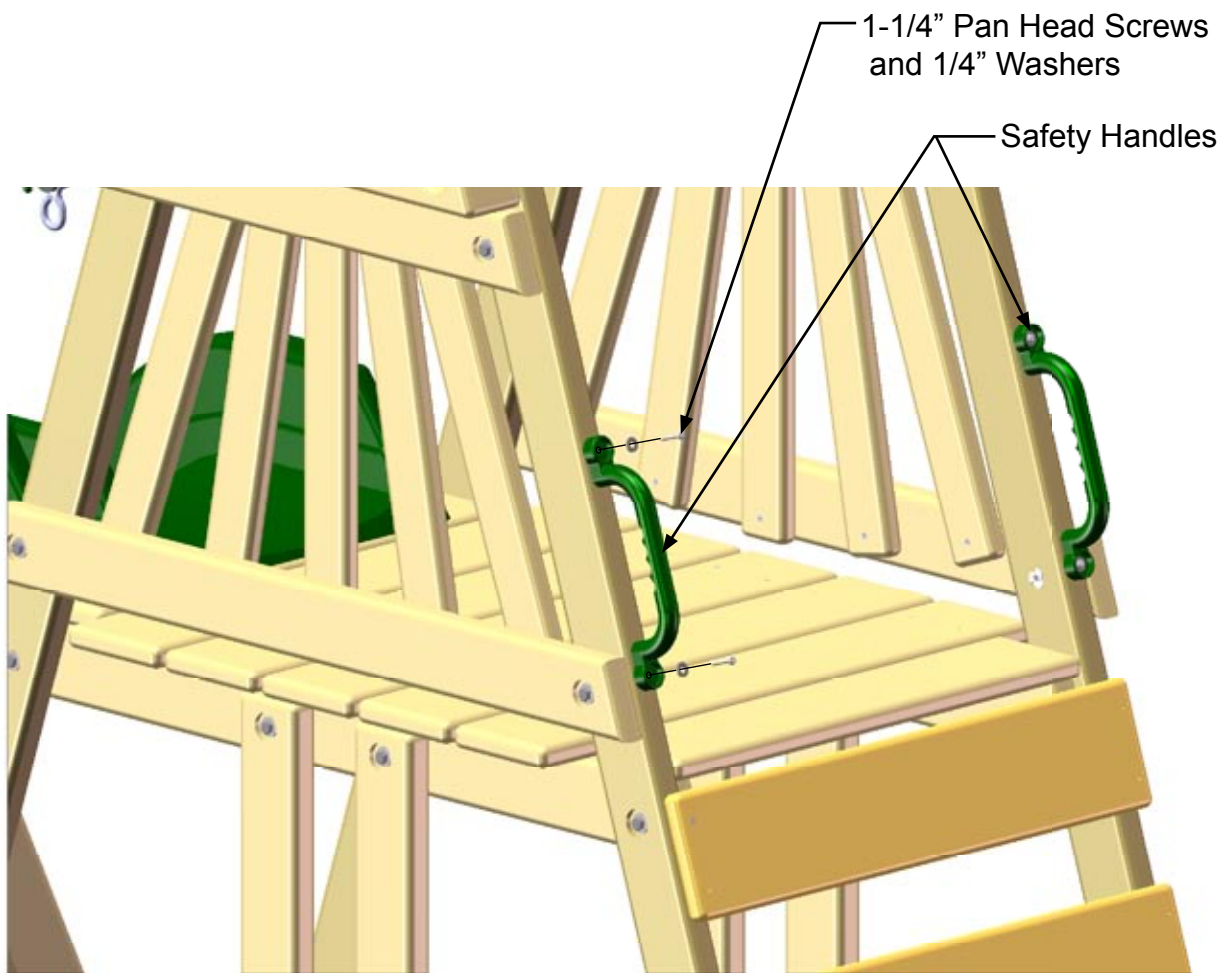

## Step 35: Flags

1: Place the Flags on the left and right sides of the play set on the Center Tarp Supports as shown below. Note Tarp has been removed for clarity.

2: Attach the plastic base of each Flag to the Center Tarp Support with the 1/2" phillips head screws provided with the Flags.

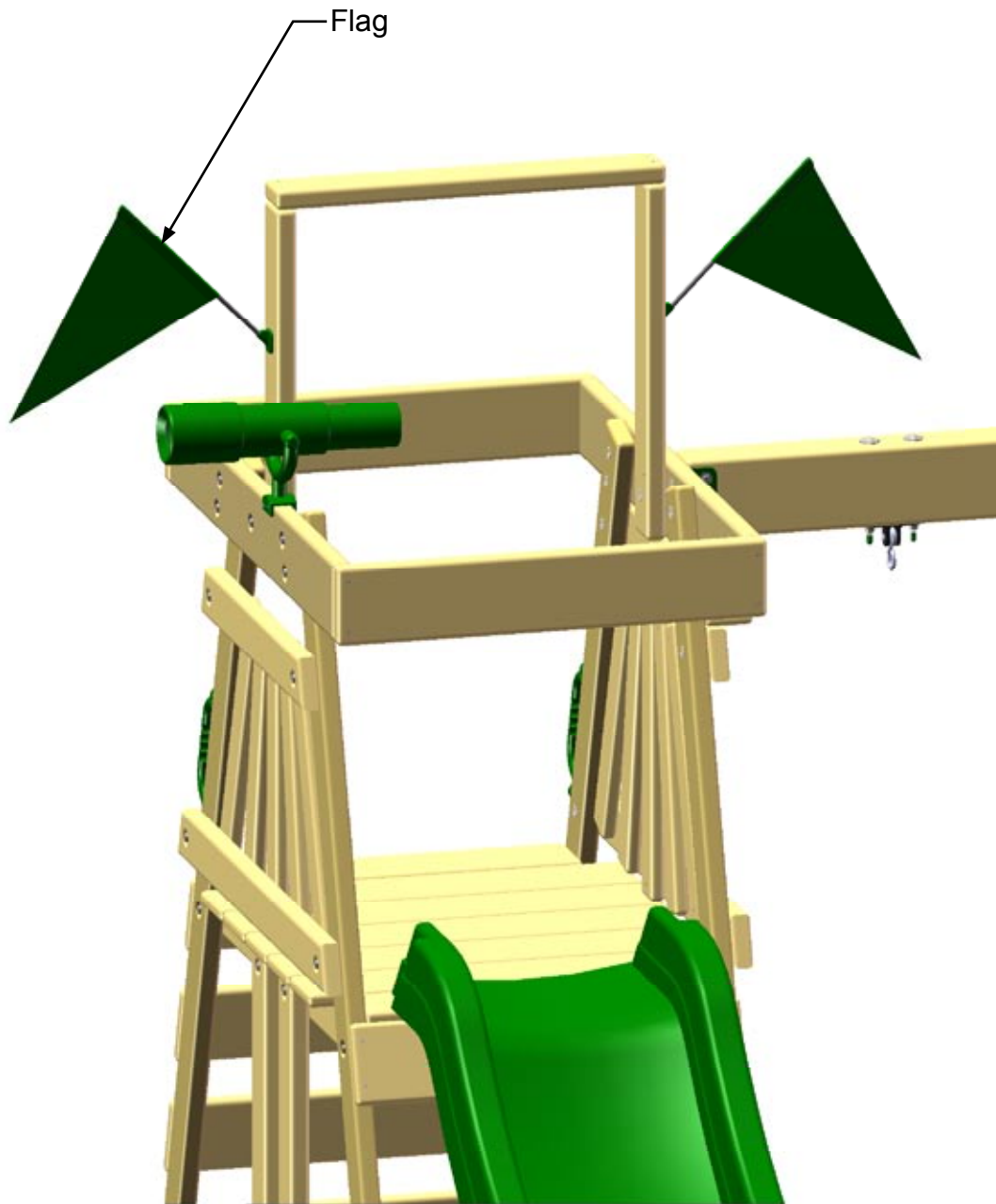

## Step 36: Ground Stakes

- 1: Hammer each Ground Stake into the ground at an inward angle next to the 2 x 6 and 2 x 4 boards as shown below. Place a scrap piece of cardboard behind the Ground Stake to avoid hitting the board with your hammer.
- 2: Once the Ground Stake is hammered into the ground remove the scrap cardboard.
- 3: Attach the Ground Stake to the board with one 5/16" x 1-1/2" lag screw and TWO 5/16 washers
- 4: Place a 3/8" bolt cap over the end of the Ground Stake.
- 5: Repeat substeps 1-4 for the remaining Ground Stakes.

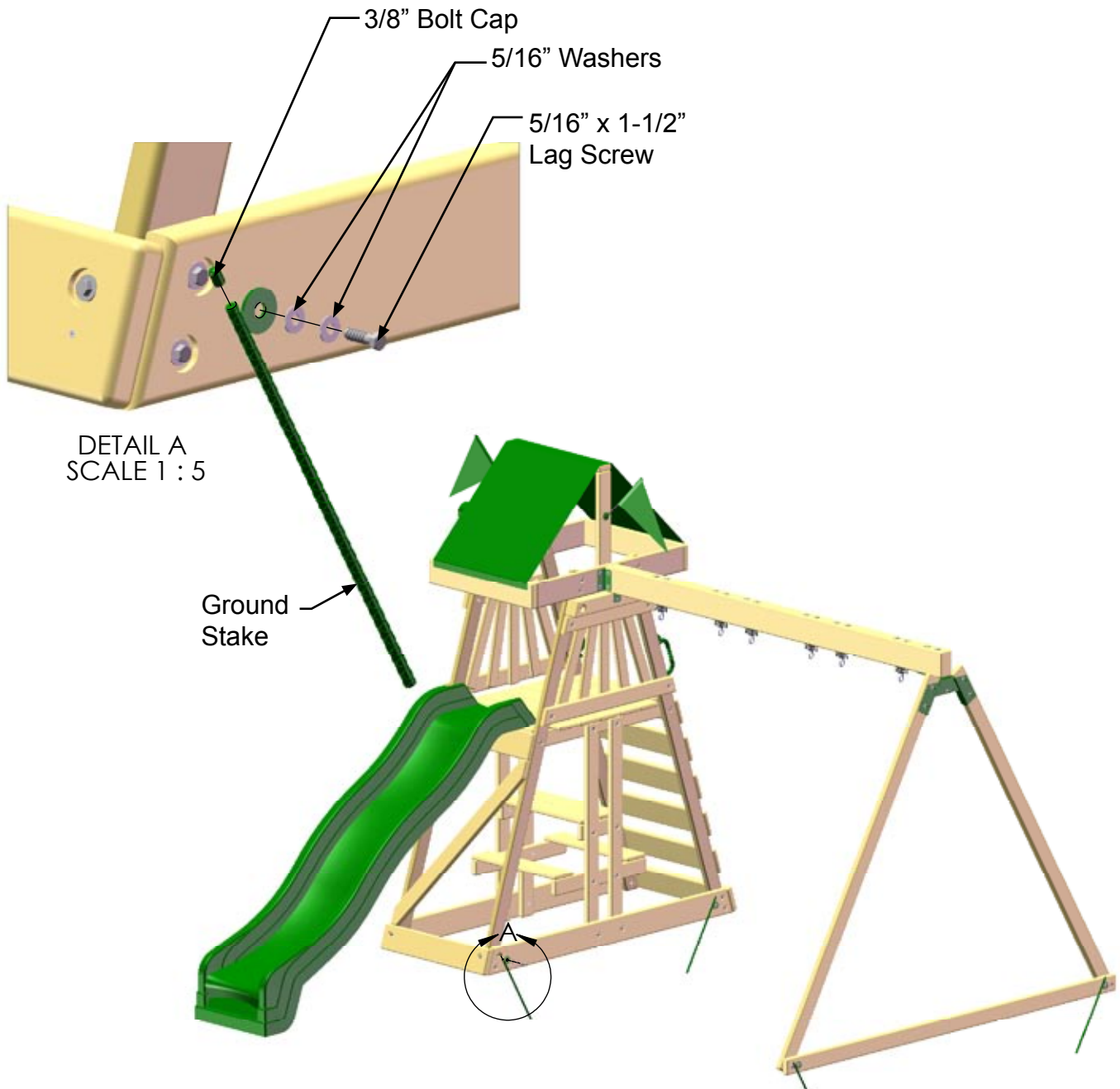

### Step 37: Hanging Swings

- 1: Hang each swing to the Mini Iron Ductile Swing Hangers by placing a chain link over the hook end of the swing hanger.
- 2: Count equal numbers of chain links on each swing chain to move the swing up or down.



## Step 38: Rock Wall Rocks

1: Place the Rock Wall Rocks onto the Rock Wall Boards in a staggered pattern as shown below.

2: Attach each Rock Wall Rock to the Rock Wall Board with the #14 x 1-1/4" pan head screws and 1/4" washers provided with the Rocks.

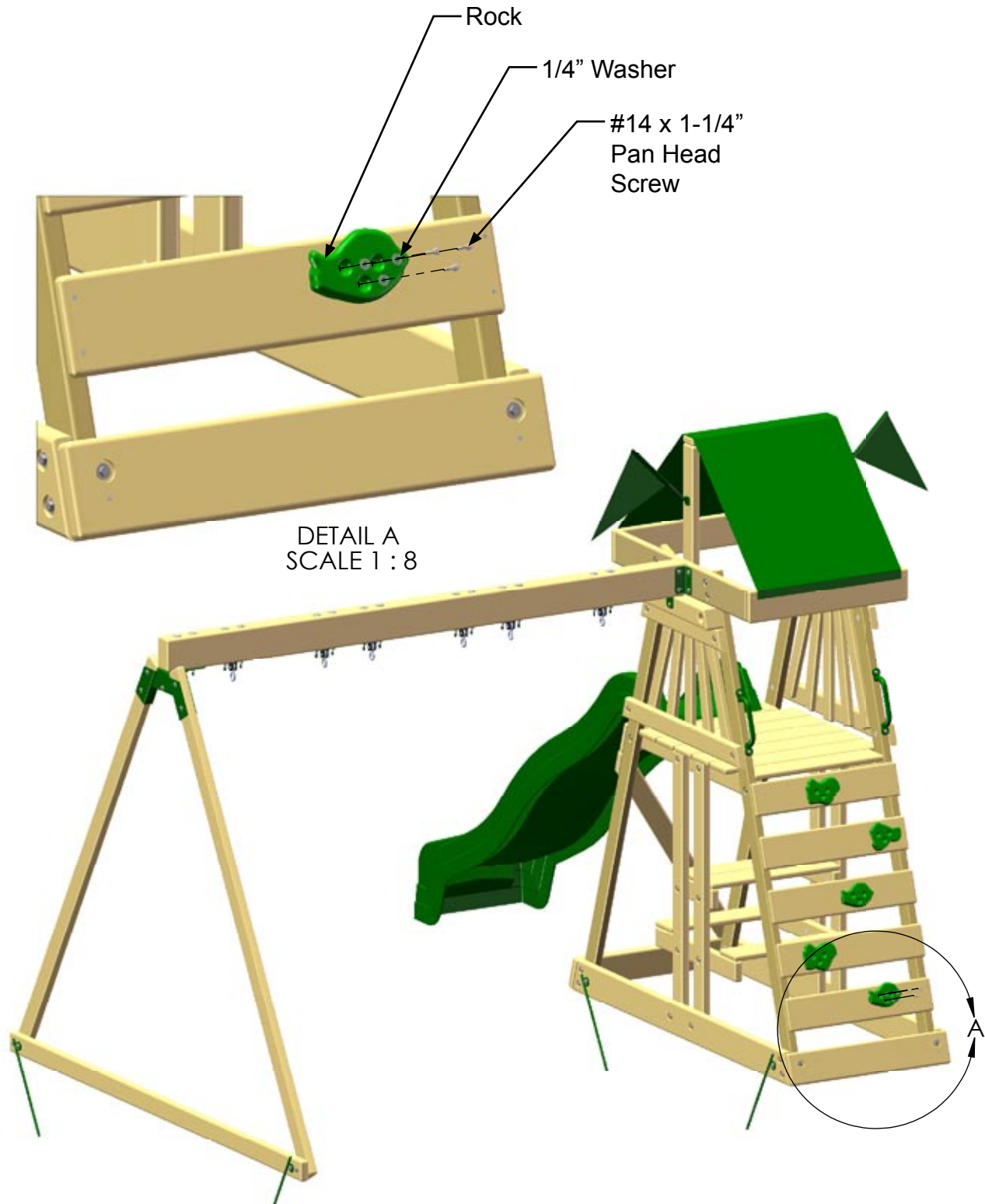

### Step 39: Gorilla Name Plate

- 1: Attach the Name Plate to the middle of the Swing Beam with two 2" wood screws.
- 2: Your play set is finished! Enjoy your play set!



## WARRANTY REGISTRATION CARD - Journey

Name: \_\_\_\_\_

Address: \_\_\_\_\_

City, State, Zip: \_\_\_\_\_

Email: \_\_\_\_\_

Date of Purchase: \_\_\_\_\_

Place of Purchase: \_\_\_\_\_

City, State, Zip: \_\_\_\_\_

Please, check the boxes below.

Your age?

- 18-25  26-30  31-35  36-40  41-45  46-50  51-55  56-60  
 61-65  66+

How old are your children?

- 2-3  4-5  6-7  8+

How would you rate the quality of our product?

- Excellent  Above average  Average  Below average  Poor

Would you recommend this product?

- Yes  No

Comments:

---

---

---