

Chesapeake™

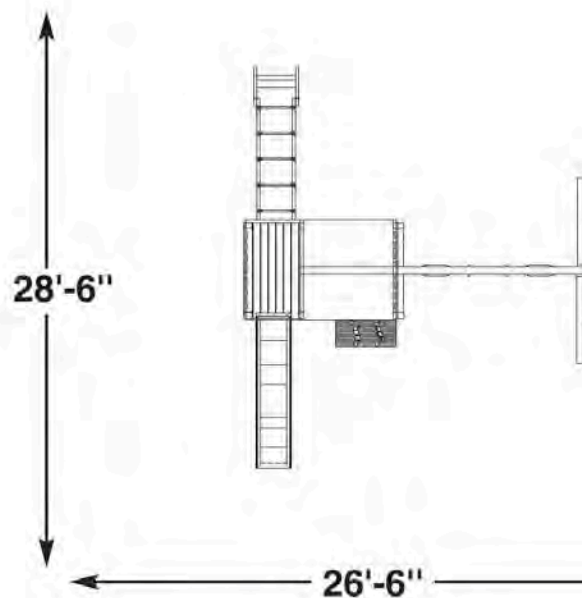
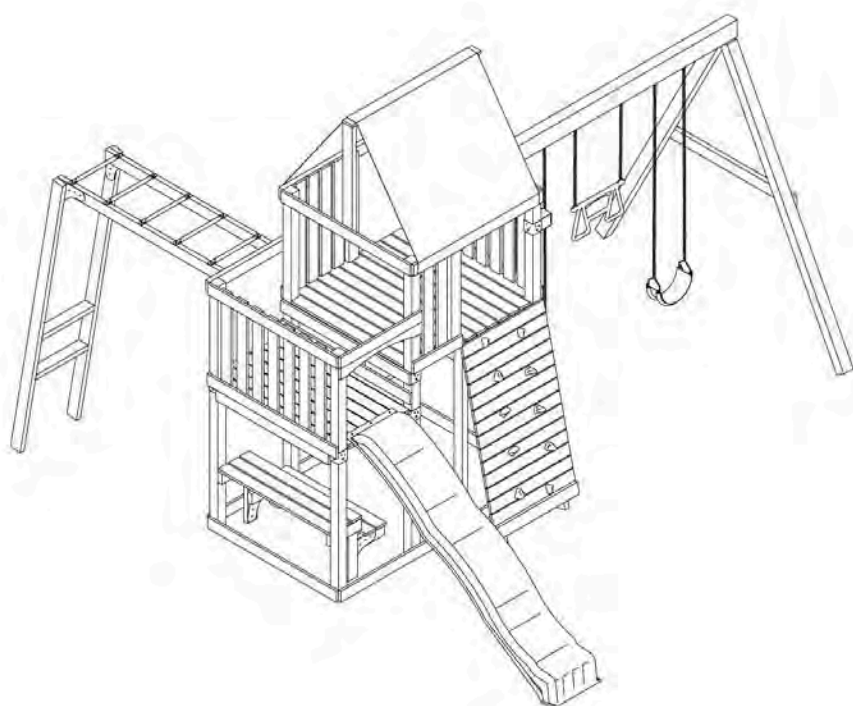

No. of Children: Up to 12
Min. Use Zone: 26-1/2' x 28-1/2'
Set Dim. 14-1/2'W x 16-1/2'L x 11'H
Est. Building Time: 5-10 hr.

Rapid
Loc[™]
System

ASSEMBLY INSTRUCTIONS

Safety Checklist for Play Sets and Accessories

Observing the following statements and warnings reduces the likelihood of serious or fatal injury

Installation Safety – Have You:

- Consulted the assembly instructions supplied with your particular model?
- Noted this accessory is to be used only on approved designs? (Do not alter its design or add/remove components.)
- Made sure all hardware is tightened securely? (Supplied bolt covers must also be fastened securely.)
- Using a hacksaw, cut off all protruding threaded ends of bolts and other fasteners and remove any sharp edges with a metal file as needed?
- Placed the equipment on level ground, not less than six feet (1.8 meters) from any structure or obstruction such as a fence, garage, house, overhanging branches, laundry lines, or electrical wires?
- Made sure home playground equipment is not installed over concrete, asphalt, packed earth or any other hard surface? (A fall onto a hard surface can result in serious injury to the equipment user.)
- Verified that suspended climbing ropes, chain, or cable are secured at both ends?
- Consulted in assembly instructions of your particular model for minimum use zones?
- Followed all anchoring and shock absorbing surfacing requirements on the back of this sheet as they apply?
- Made sure not to allow children to use equipment until it is properly installed?

Operating Safety – Have You:

- Determined that on-site adult supervision is provided for children of all ages?
- Warned children the following before allowing them to use the equipment?
 - Not to walk close to, in front of, behind or between moving items.
 - Not to twist swing or any other accessory chains or ropes or loop them over the top support bar since this will reduce the strength of chain or rope.
 - Not to swing empty seats or other accessories.
 - Be sure to sit in the center of the swing seat and other accessories with full weight on the seat.
 - Not to attach items to the playground equipment that are not specifically designed for use with the equipment such as but not limited to, jump ropes, clotheslines, pet leashes, cables and chain. They may cause a strangulation hazard.
 - Not to use equipment in a manner other than intended.
 - Not to get off equipment while it is in motion.
 - Not to climb on the equipment when it is wet.
- Determined that only one child per planned occupant seat should be allowed on this set at one time.
- Determined children must be dressed appropriately for play. Avoid clothing with draw strings and loose fitting clothes which could become entangled or snagged on equipment.
- Determined that suspended climbing ropes, chain, or cable cannot be looped back upon itself.
- Read and understood the following warning regarding the use of two and four passenger lawn swings?

Warning: Lawn Swings are designed for use by children over two years of age. Use by children under the age of two can result in entrapment between the seats and back areas. **Never** place children in a rearward facing position or with legs between the seat and backrest because the child's body may pass through the opening causing entrapment of the child's head.

Safety Maintenance – Have You Determined to:

- Check all nuts and bolts twice monthly during the usage season for tightness and tighten as required? (It is particularly important that this procedure be followed at the beginning of each season.)
- To prevent the deterioration of materials, remove plastic swing seats and other plastic accessories and take indoors? (Do not use when the temperature drops below 0° F.)
- Oil all metallic moving parts monthly during usage period?
- Check all hardware and equipment for sharp edges twice monthly during usage season? (Replace when necessary. It is especially important to do this at the beginning of each new season.)
- Check swing seats, chains, ropes and cables monthly during usage season for evidence of deterioration? Severe rusting or excessive wear, especially near the top swing hanger or at the seat connection are evidence of chain deterioration. Cracks in the protective plastic sleeve or seat itself are also signs of deterioration. If any of these conditions exist, call 1-800-888-1232 to order replacement accessories.
- Sand rusted metal parts and repaint using non-lead based paint.

Disposal Instructions

When the equipment is taken out of service, it must be disassembled and disposed of in such a way that no unreasonable hazards will exist at the time the set is discarded.

**Important! Additional Safety Instructions for all Playground Equipment.
Save this instruction sheet in the event the manufacturer needs to be contacted.**

This product is intended for single family home/residential use only and not intended for use in any public setting. Placement in any public setting constitutes a misuse of this product.

IMPORTANT!

ADDITIONAL REQUIRED SAFETY INSTALLATION INSTRUCTIONS

According to ASTM requirements, all kits must be anchored to the ground and, if the unit has a climbing rope, the rope end must be anchored to the ground. If soil conditions permit stakes to be pulled out easily, cementing into ground is necessary.

- **To anchor the unit to the ground,** Follow the instructions included in this plan for applying Anchor-It devices to your unit, or use 2" x 4" x 18" (45mm x 95mm x 457mm) pressure-treated stakes. Pound stakes into ground at least 12" (305mm) at all inside corners of the posts (including A-frame legs and climbing unit posts). Attach with four (4) 16D (3-1/2") galvanized nails per stake into each 4" x 4" (95mm x 95mm) post.
- **If the unit has a climbing rope,** anchor the rope end.
- **Once the unit is completely assembled and before children are allowed to play on it, proper shock-absorbing surfacing material must be installed.** This may be accomplished by using loose-fill materials at a sufficient depth. The Consumer Product Safety Commission "Handbook for Public Playground Safety" lists the following materials and required depths that are sufficient for home/residential application. For fall height protection up to 9 ft. (2.742m) [recommended for Swing•N•Slide kits]:

<u>LOOSE FILL MATERIAL</u>	<u>REQUIRED (UNCOMPRESSED) DEPTH¹ in. (mm)</u>
Wood Mulch	9" (229mm)
Double Shredded Bark Mulch	9" (229mm)
Uniform Wood Chips	12" (305mm)
Fine Sand	12" (305mm)
Fine Gravel	12" (305mm)

¹These depths were derived from the CPSC Handbook. Swing•N•Slide has not done independent tests to determine these required depths.

When properly installed, shock absorbing material will completely cover the horizontal baseboards on climbing units. This protective surfacing must extend a **minimum** of 6 ft. (1.828m) in all directions from the perimeter of the equipment or from the outermost edges of any component. For example, a slide extending beyond the platform must have protective surfacing at least 6 ft. (1.828m) out from both sides as well as the end. For swings, the protective surface must extend **at least 14 ft. (6m)** out from **both** the back and front of the swing when the swing is in its rest position.

NOTES:

TOOLS REQUIRED

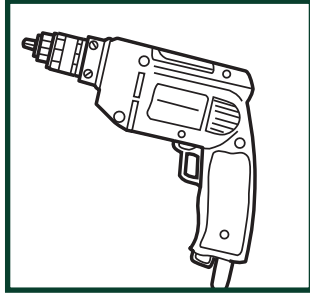

ELECTRIC DRILL



HAMMER

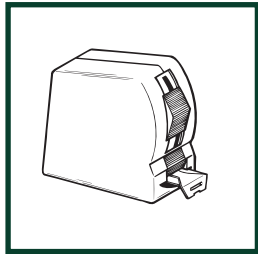

TAPE MEASURE

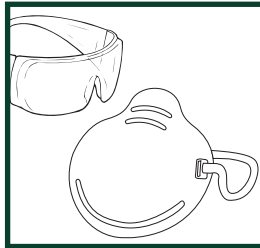

**SAFETY GLASSES
& DUST MASK**

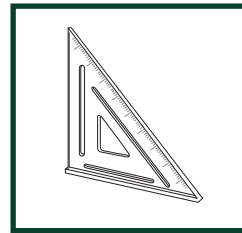

CARPENTER'S SQUARE



(2) 1/2" panhead screws

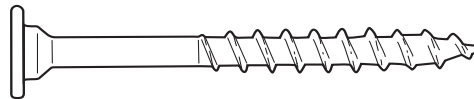

(74) 2" lag screw

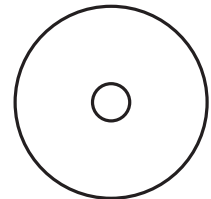

(6) Tarp Washers

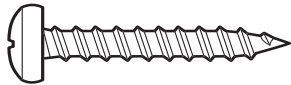

(4) 1-3/4" panhead screws

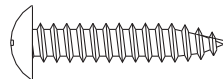

(39) 1" Truss Screws

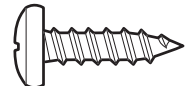

(6) 3/4" screws

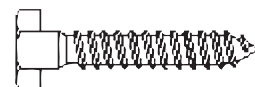

(4) 5/16" Hex Head Lag Screws



(14) Loc-Nuts



(127) 1-1/4" screws



(4) 1/4" flat washers

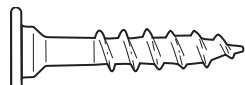

(32) 1-1/4" lag screws

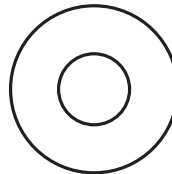

(18) 5/16" flat washers



(8) 2" screws

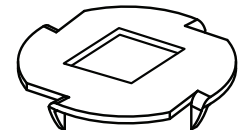

(14) Wood Loc Washers



(412) 2-1/2" screws

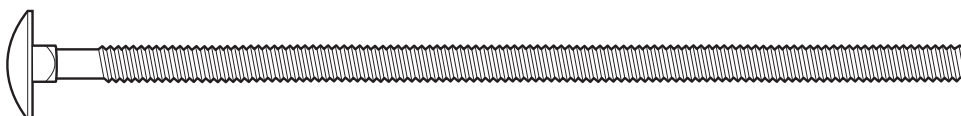

(14) 6-1/2" Bolts

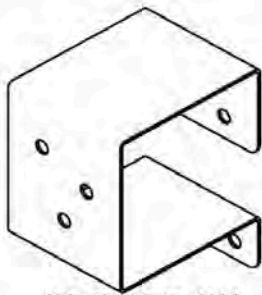

(2) 3X3 TO 4X4 Shelf-Loc

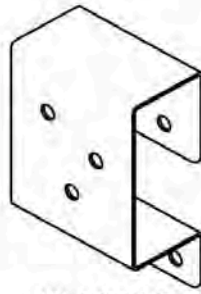

(8) 3X3 TO 2X4 Shelf-Loc

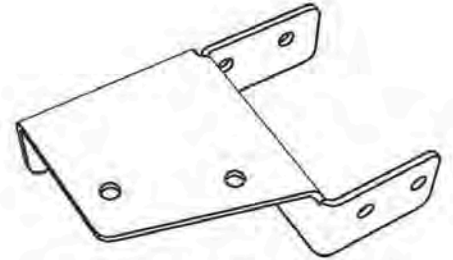

(2) Split Beam bracket

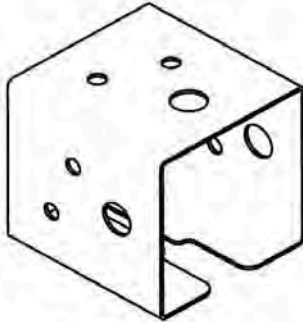

(10) Wrap-Loc

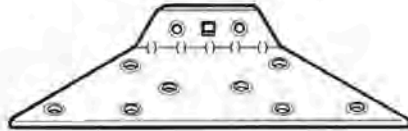

(2) EZ Frame Brackets

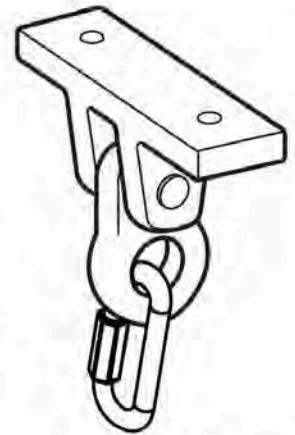

(6) Extra-Duty Swing Hangers



(1) Name Plate

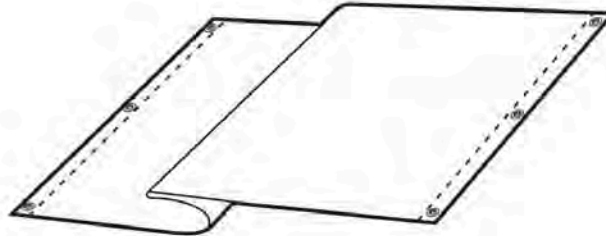

(1) Green Tarp

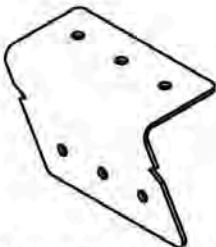

(4) Step Brackets
Note: (2 Left, 2 Right)

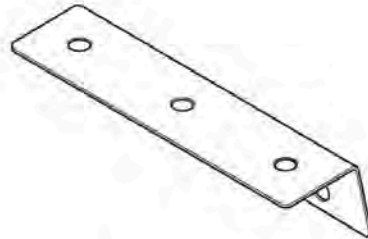

(2) 'L' Brackets

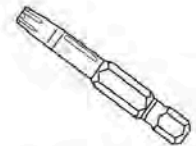

(1) T20 Torx® Bit

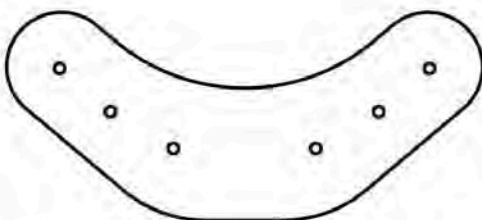

(4) Boomerang Brackets



(1) T30 Torx® Bit



(1) Plan



(4) Anchor-It Straps

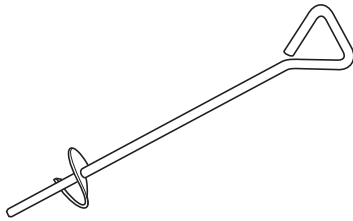

(4) Anchor-It

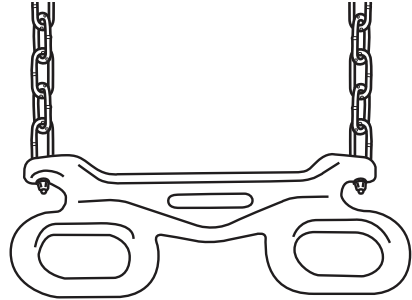

(1) Ring-Trap Combo

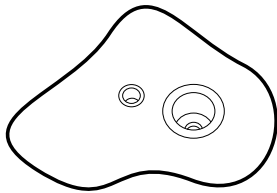

(8) Climbing Rocks w/ Hardware

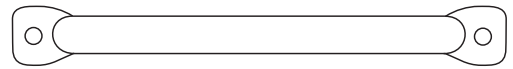

(9) Metal Rungs

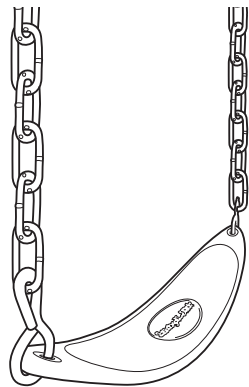

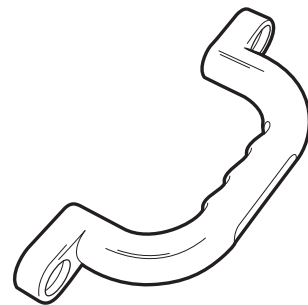

(2) Extra Duty-Swing Seats





(4) Safety Handles

CHESAPEAKE DESIGN



(1) 1" x 3" x 23-1/2"



(1) 1" x 4" x 6-1/4"



(1) 1" x 4" x 11"



(1) 1" x 4" x 18"



(1) 1" x 4" x 20-1/2"



(1) 1" x 4" x 25-3/4"



(22) 1" x 4" x 30"



(1) 1" x 4" x 30"



(14) 1" x 4" x 34"



(2) 1" x 4" x 36-1/2"

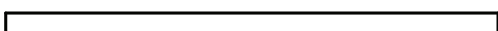

(10) 1" x 4" x 41-3/4"



(28) 1" x 4" x 47-1/2"

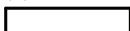

(2) 1" x 4" x 74-1/2"



(2) 2" x 3" x 59-1/4"



(2) 2" x 4" x 11-1/2"

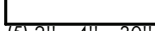

(2) 2" x 4" x 15"

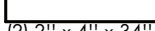

(1) 2" x 4" x 16"

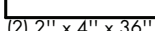

(4) 2" x 4" x 19-1/4"



(5) 2" x 4" x 30"



(2) 2" x 4" x 34"

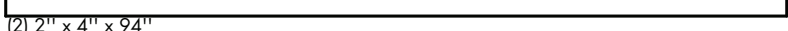

(2) 2" x 4" x 36"



(5) 2" x 4" x 47-1/2"

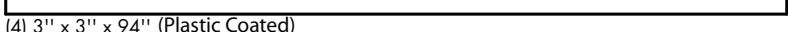

(4) 2" x 4" x 60"



(2) 2" x 4" x 94"

(2) 3" x 3" x 78" (Plastic Coated)

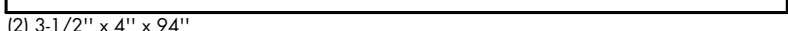
(4) 3" x 3" x 94" (Plastic Coated)

(1) 4" x 4" x 47-1/2"

(2) 3-1/2" x 4" x 94"

(1) 4" x 5-1/2" x 94"

How to select the correct fastener

Use these 2 pictorial guides to help select the correct fastener(s) for the lumber attachment you are making. Each diagram will highlight the correct number of fasteners to use, and where to attach them.

1" x 4" or 2" x 4" to 3" x 3"



(3) 2-1/2" screws

Apply 2 1/2" screws to the 2"x4" boards when attaching to 3"x3" uprights.

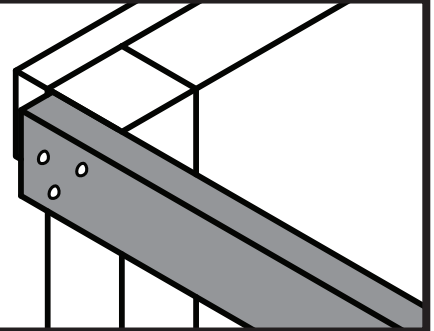

1" x 4" to 1" x 4" or 2" x 4"



(2) 1-1/4" screws

Use 1-1/4" screws when mounting 1" boards to 2"x4" boards.

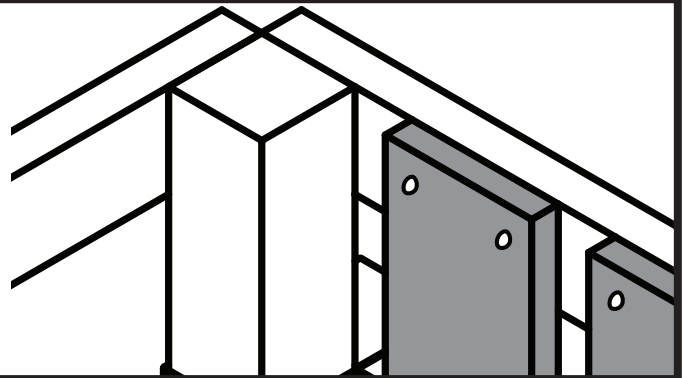

Understanding how the Bracket System Works

Example of a Shelf-Loc bracket connection.

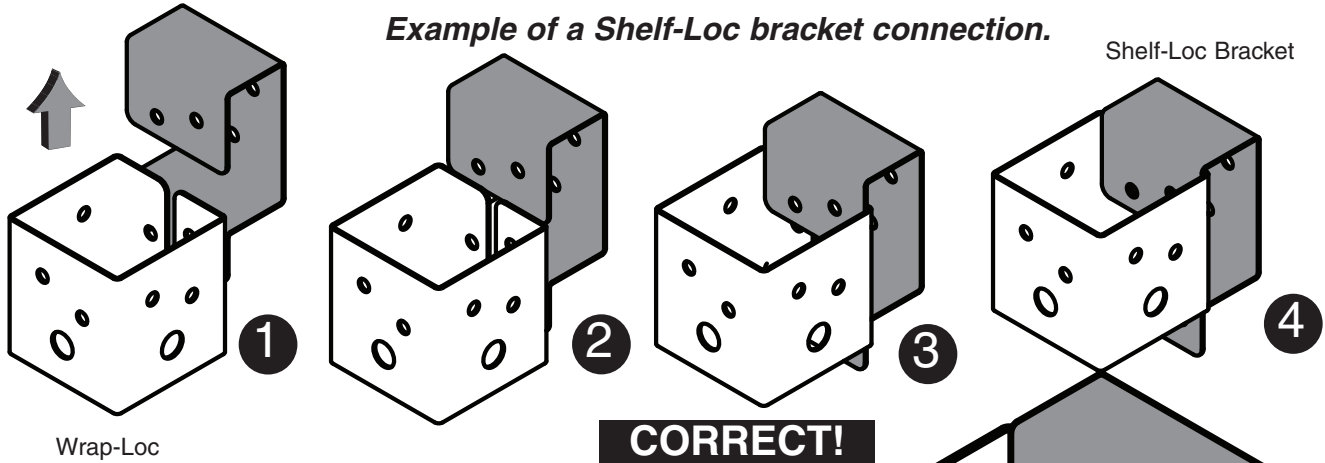

WRONG!

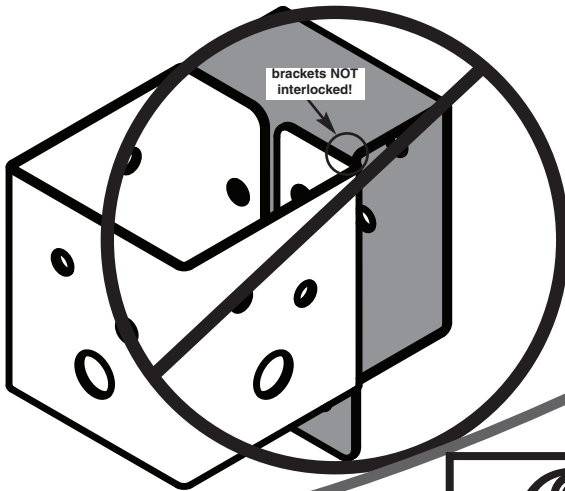

Example of a Shelf-Loc bracket connection.

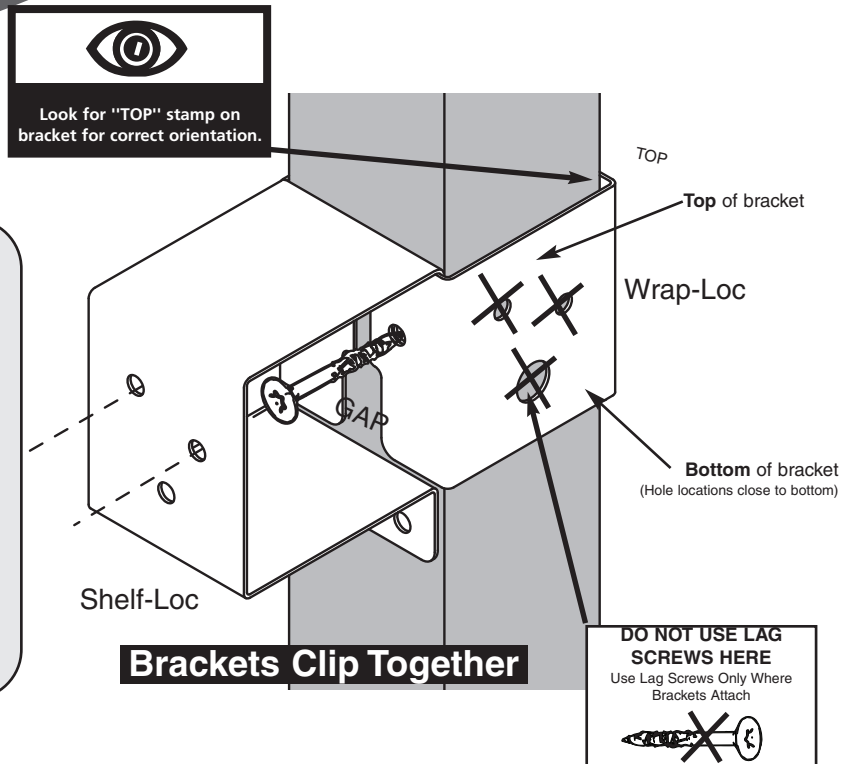

Introduction to the Bracket system

1. **ALWAYS** Use 1-1/4" or 2" lag screws on all brackets.
2. Brackets "clip" to each other. **NEVER** position in a non-interlocking position.

NOTE: PLACE SCREWS IN BRACKETS **ONLY WHERE INSTRUCTED. DO NOT FILL EVERY HOLE IN BRACKET.** THIS WILL LEAD TO HARDWARE SHORTAGES.

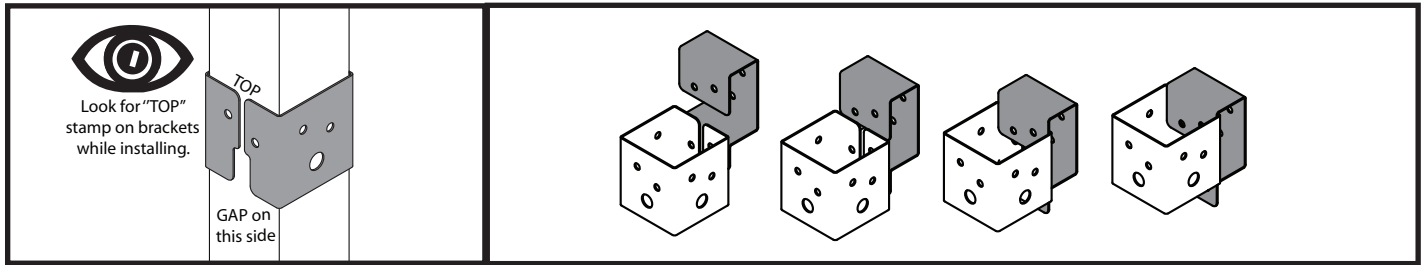

Frame 1 Construction

Fig.1

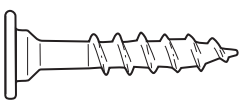
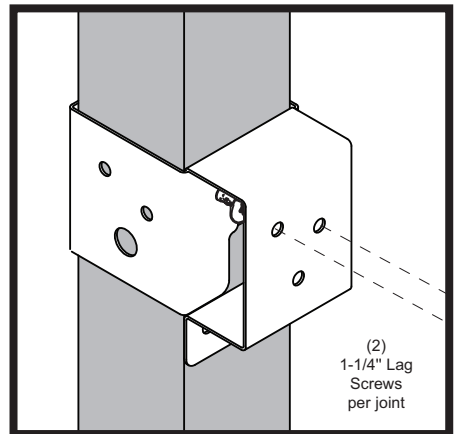
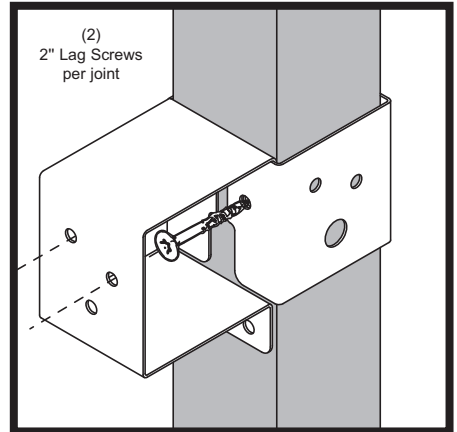
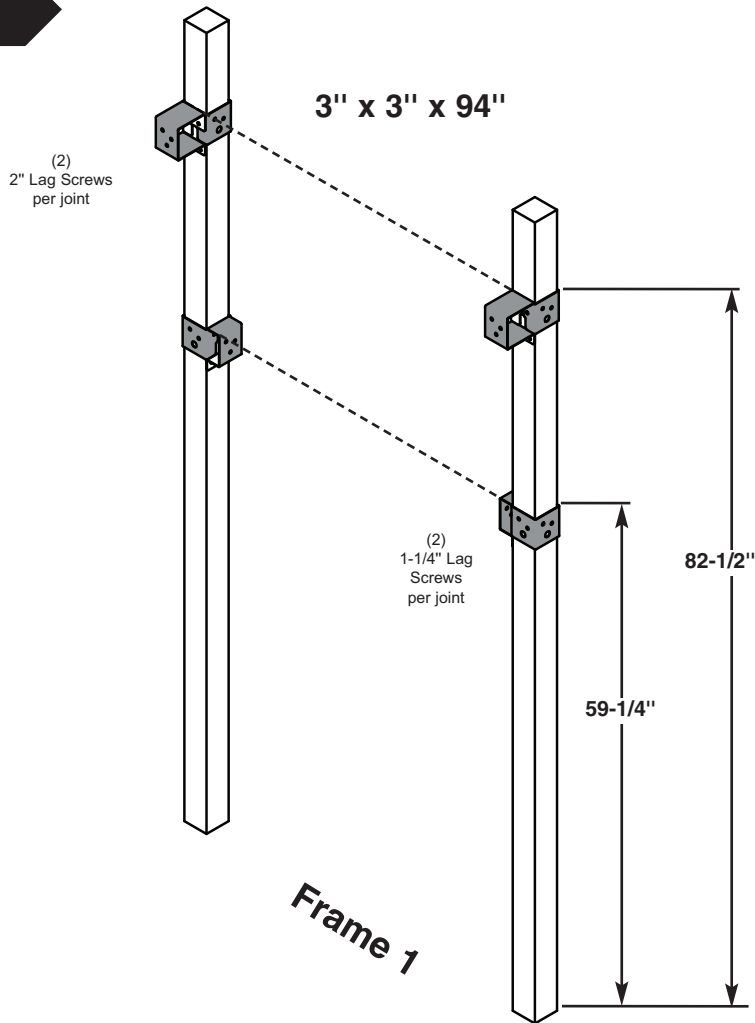

1-1/4" Lag screw

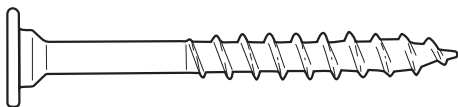

2" Lag screw

A. Frame 1 Construction

1. Measure and position brackets on 3" x 3" as shown in **(Fig.1)**.

Note: Secure Shelf Lock with **(2) Lag Screws only** at this time.

•WARNING•
 Avoid splitting your
 lumber by offsetting
 your screws at least
 3/4" from edge.

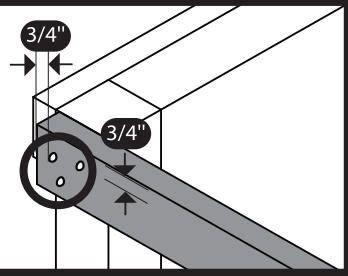

Frame 1 Construction

Fig.1a

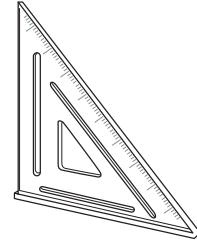

**Double check to make
 sure structure is square**

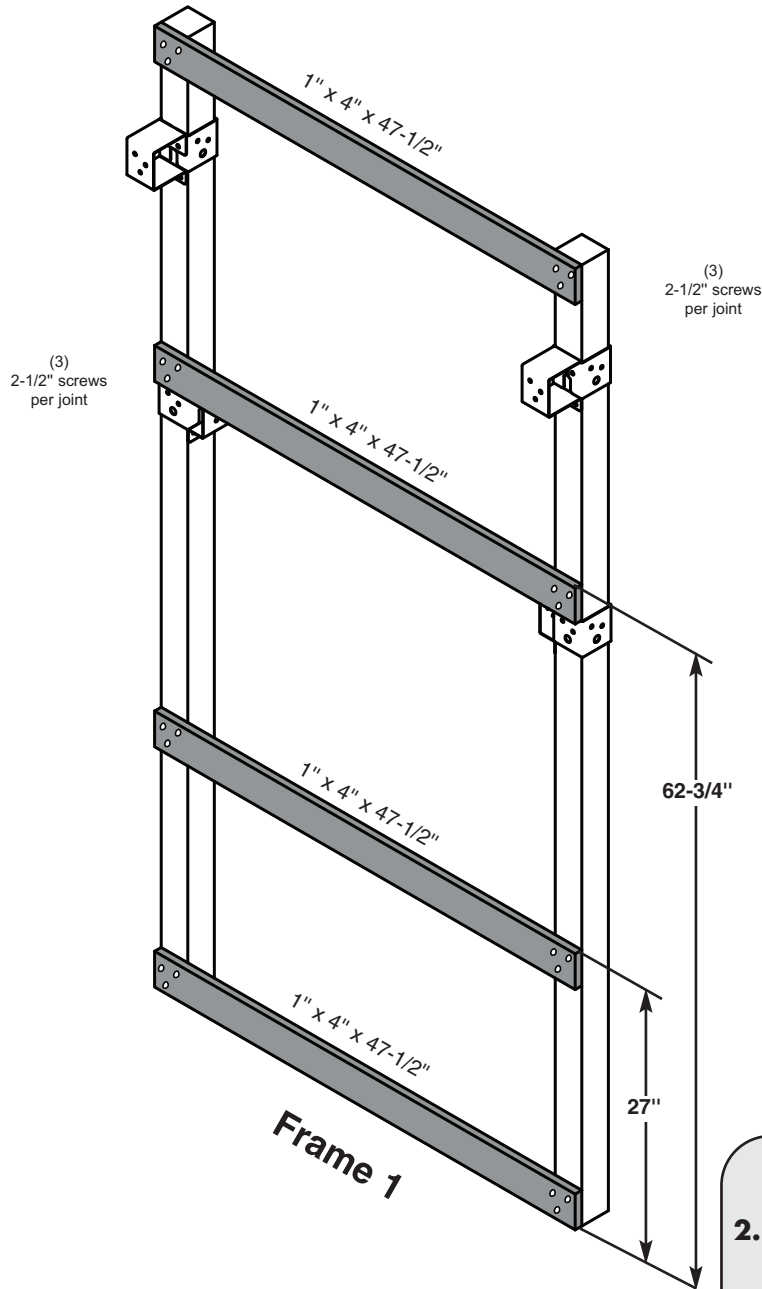

2-1/2" screw

A. Frame 1 Construction cont.
2. Attach 1" boards as shown in (Fig. 1a).

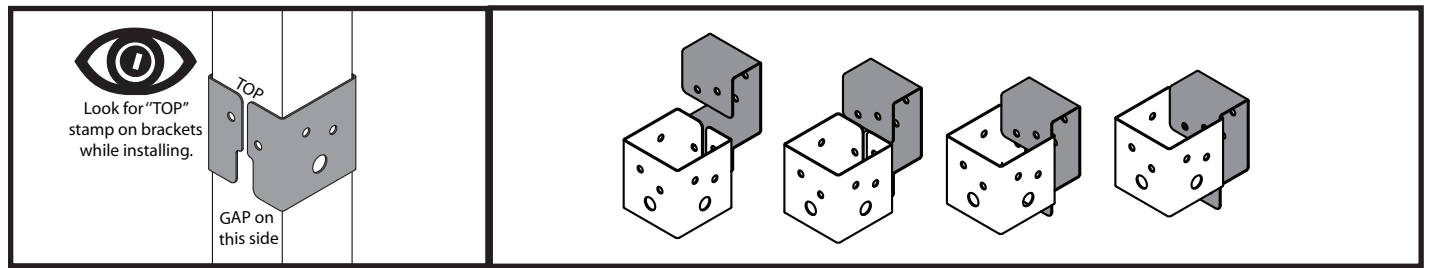
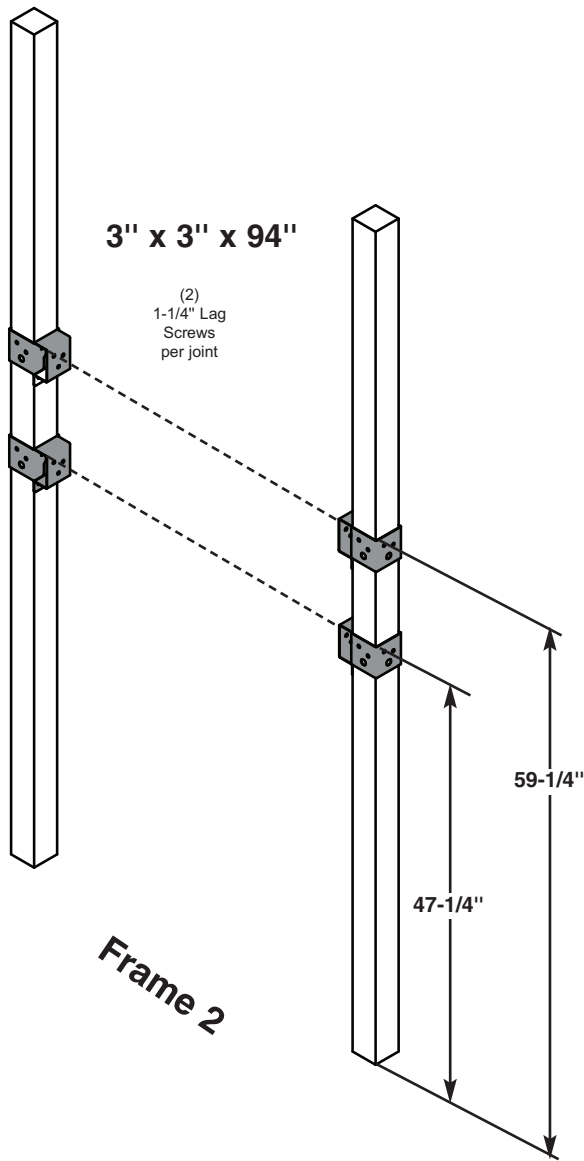
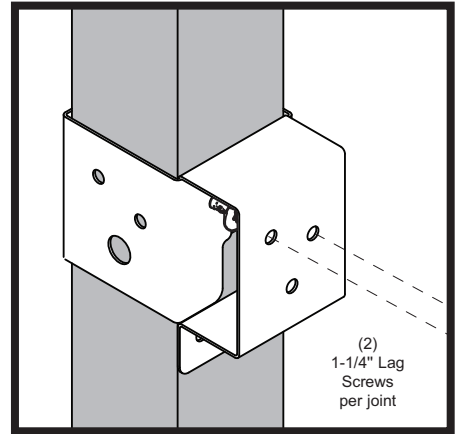
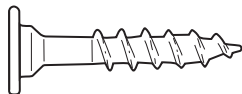

Fig.2 Frame 2 Construction



1-1/4" Lag screw



B. Frame 2 Construction

1. Measure and position brackets on 3" x 3" as shown in **(Fig.2)**.

Frame 2 Construction

Fig.2a

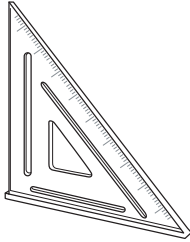

Double check to make sure structure is square

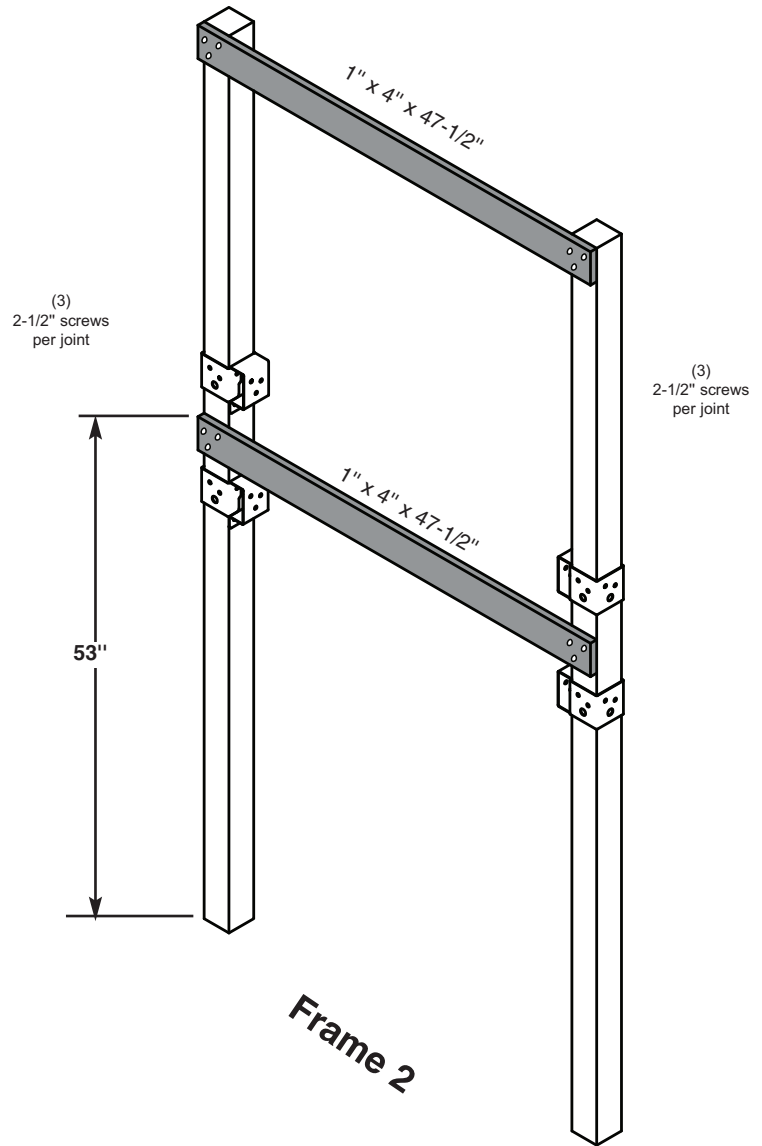

B. Frame 2 Construction cont.
2. Attach 1" boards as shown in (Fig. 2a).



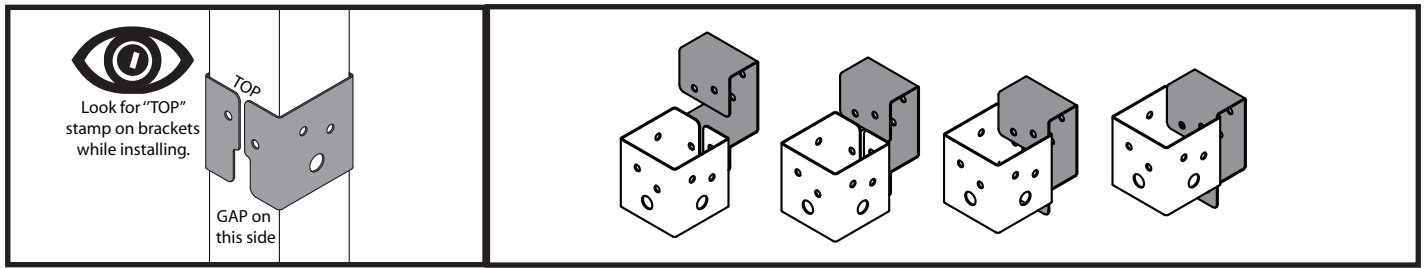
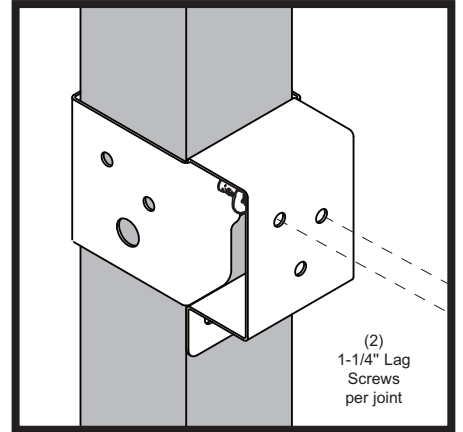
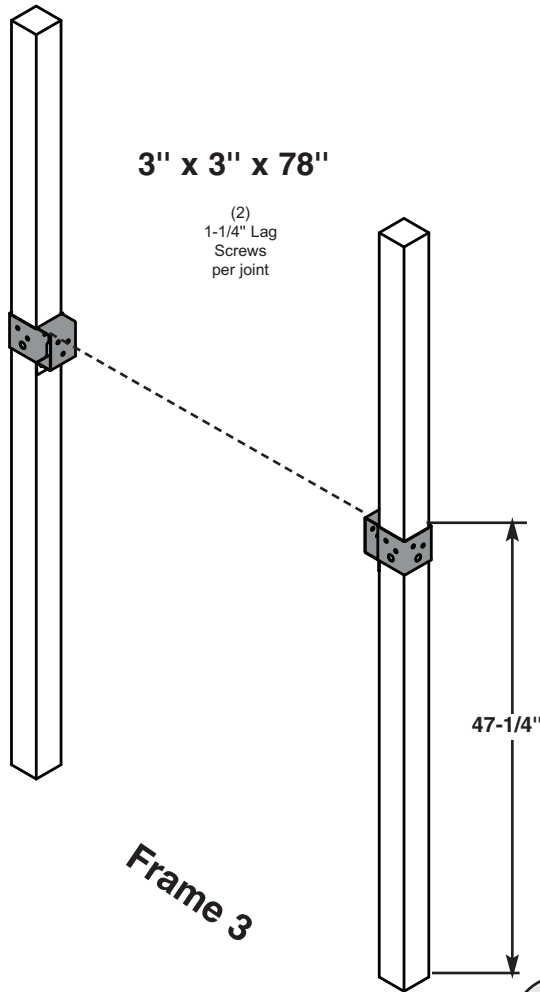
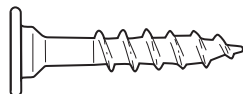

Fig.3 Frame 3 Construction



1-1/4" Lag screw



B. Frame 3 Construction

1. Measure and position brackets on 3" x 3" as shown in **(Fig. 3)**.

Frame 3 Construction

Fig.3a

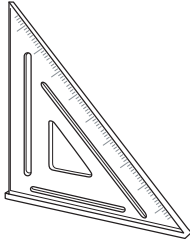

Double check to make sure structure is square

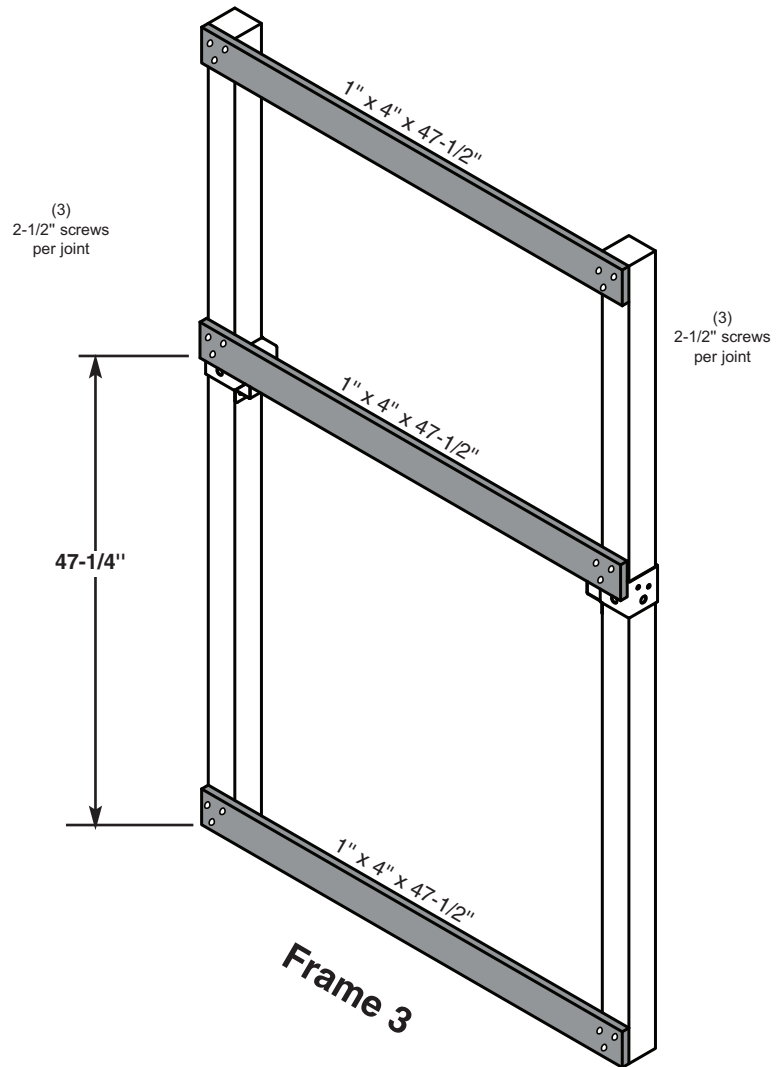

B. Frame 3 Construction cont.
2. Attach 1" boards as shown in (Fig. 3a).



Fig. 4

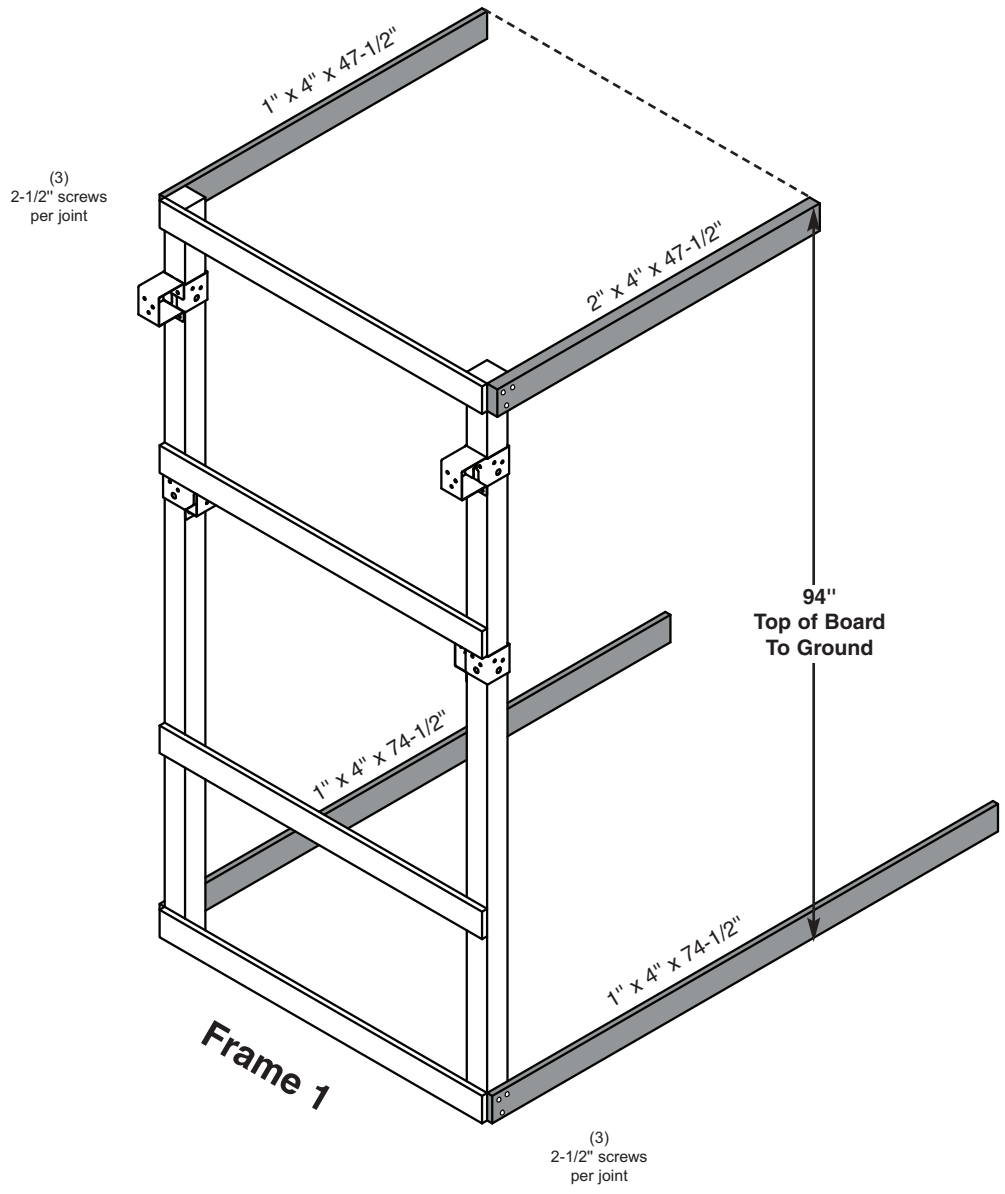

D. Frame Construction

1. Install support boards as shown above.



2-1/2" screw

Fig. 5

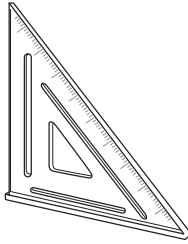

Double check to make sure structure is square

(3)
2-1/2" screws
per joint

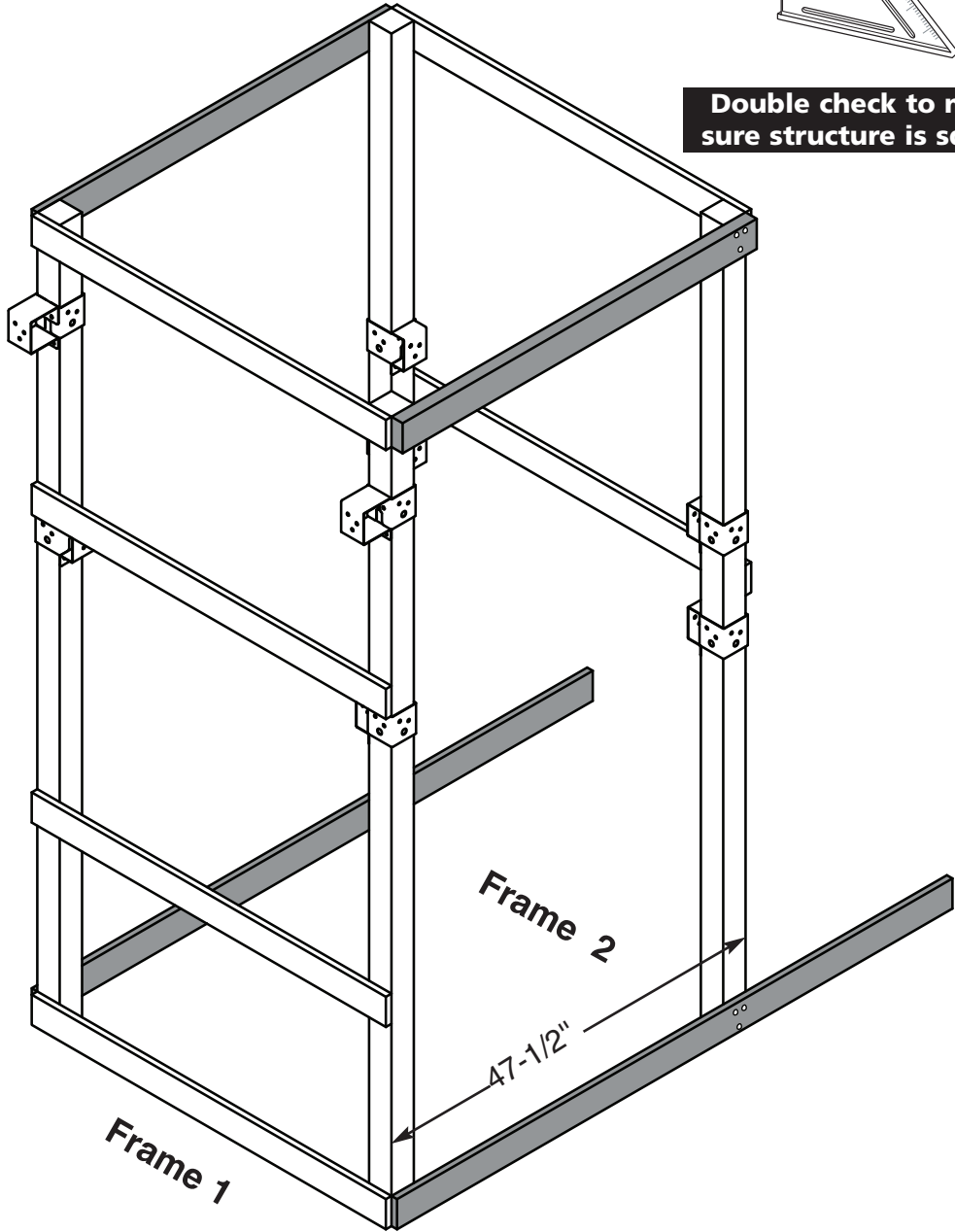

(3)
2-1/2" screws
per joint

2-1/2" screw



D. Frame Construction cont.
1. Attach Frame Two as shown above.

Fig. 6

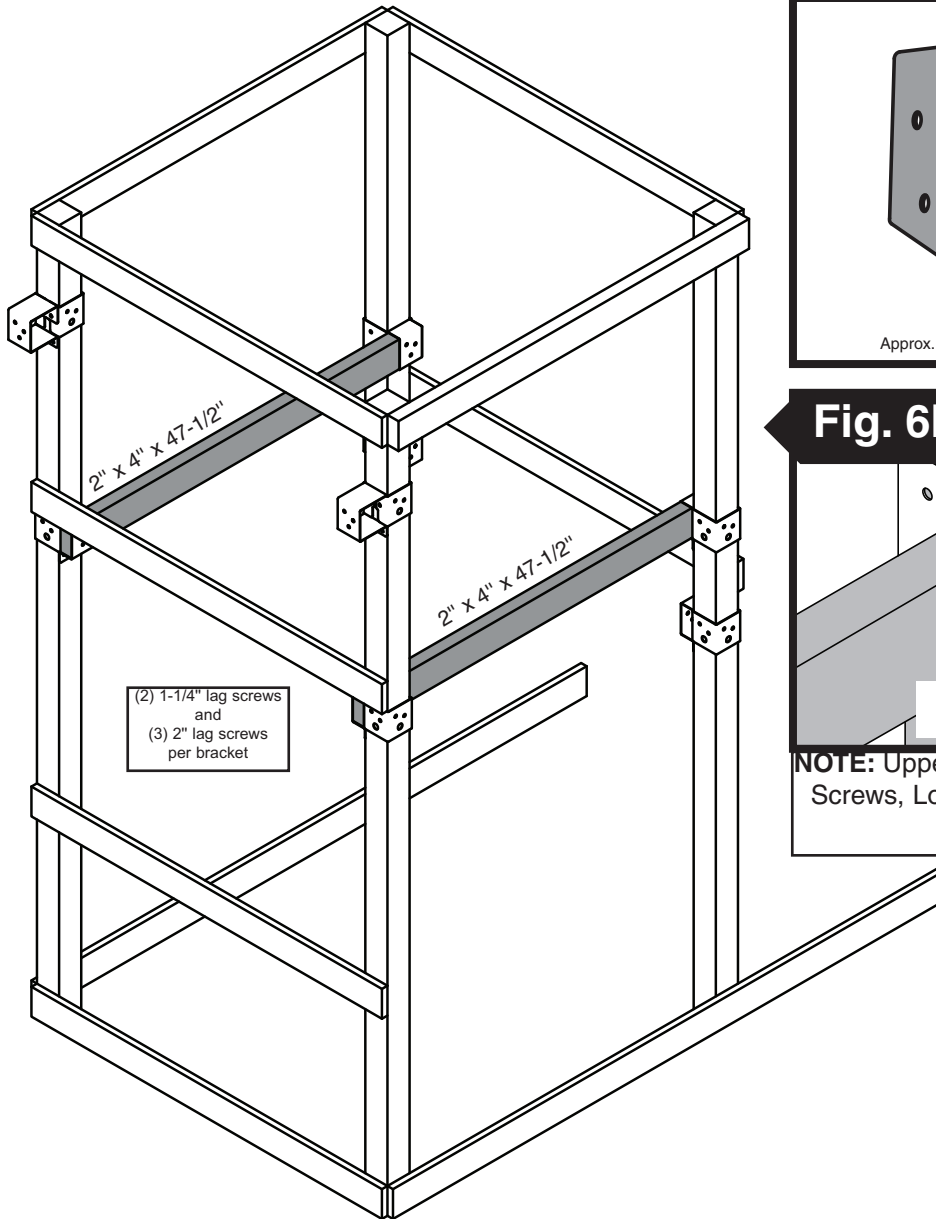

(2) 1-1/4" lag screws
and
(3) 2" lag screws
per bracket

Tip: Flex brackets to make installation of 2" x 4" easier

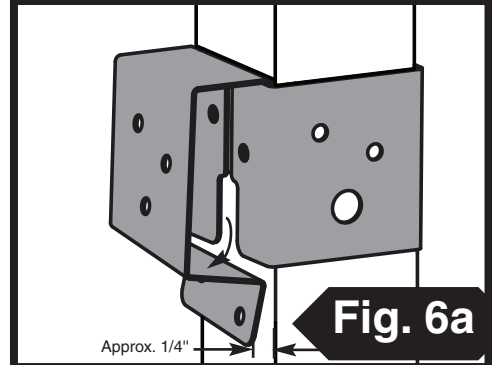
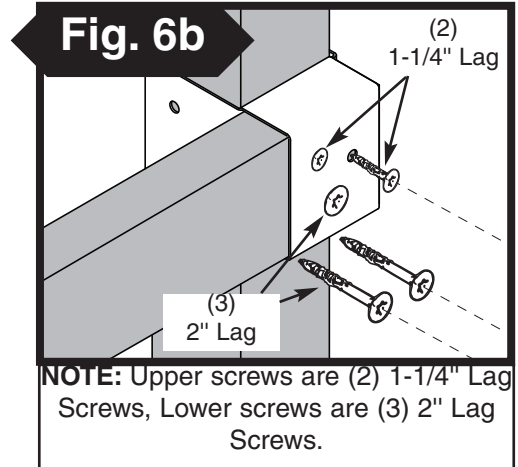

Fig. 6a



NOTE: Upper screws are (2) 1-1/4" Lag Screws, Lower screws are (3) 2" Lag Screws.

E. Install 2" x 4" Supports

1. Install 2" x 4" boards as shown in (Fig.6), (Fig. 6a), and (Fig. 6b).

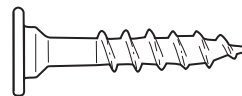

1-1/4" Lag screw

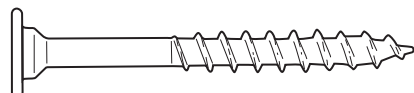

2" Lag screw

Fig. 7

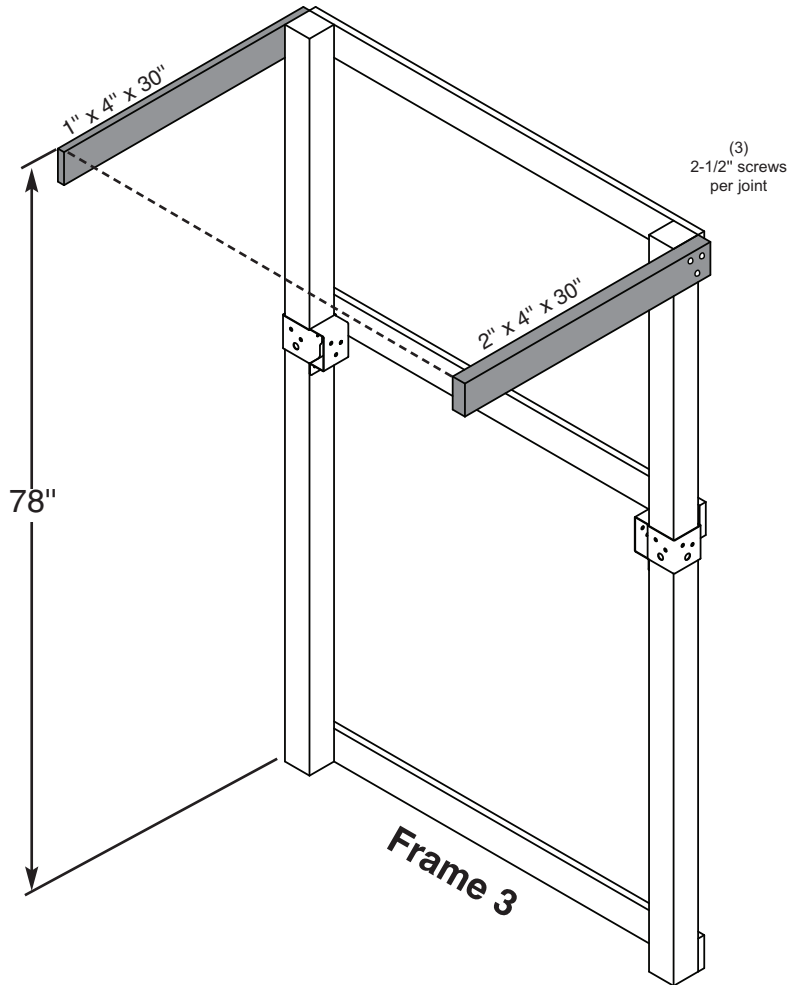

2-1/2" screw

F. Frame 3 Construction

1. Measure and position 1" x 4" and 2" x 4" as shown in **(Fig.7)**.

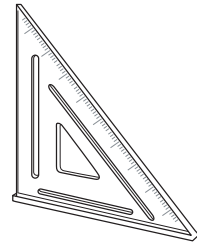
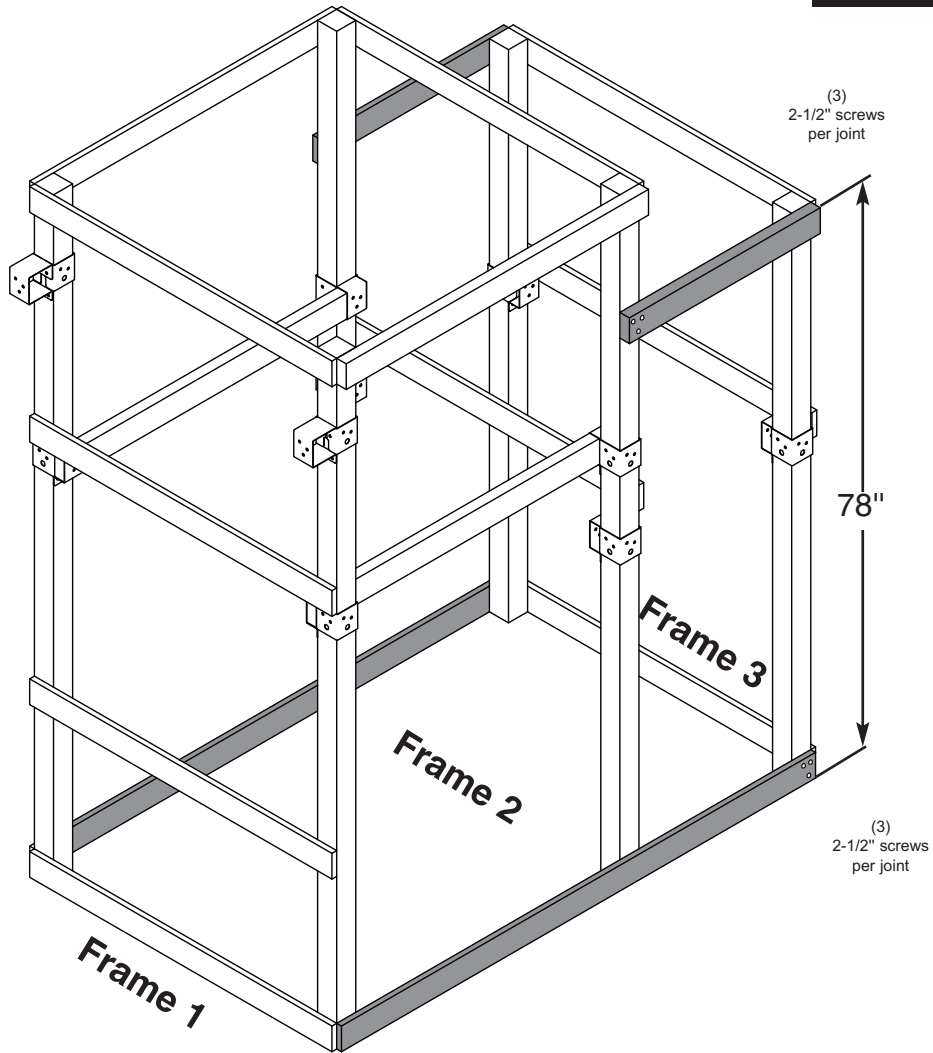

Fig. 8

(3)
2-1/2" screws
per joint

**Double check to make
sure structure is square**



2-1/2" screw

G. Install Frame 3

1. Install Frame 3 by securing 2" x 4" and 1" x 4" boards as shown in **(Fig. 8)**.

Tip: Flex brackets to make installation of 2" x 4" easier

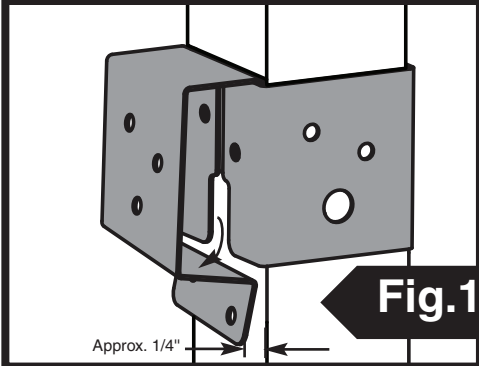
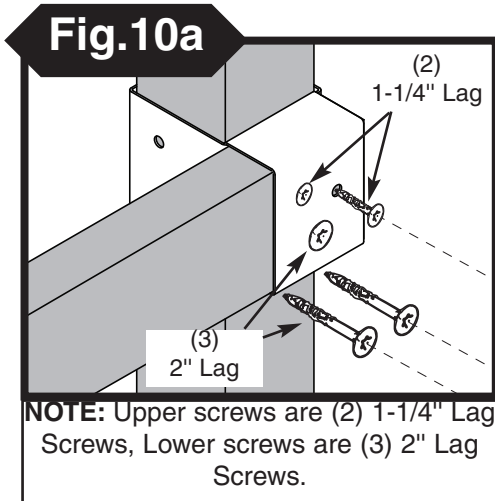

Fig.10



NOTE: Upper screws are (2) 1-1/4" Lag Screws, Lower screws are (3) 2" Lag Screws.

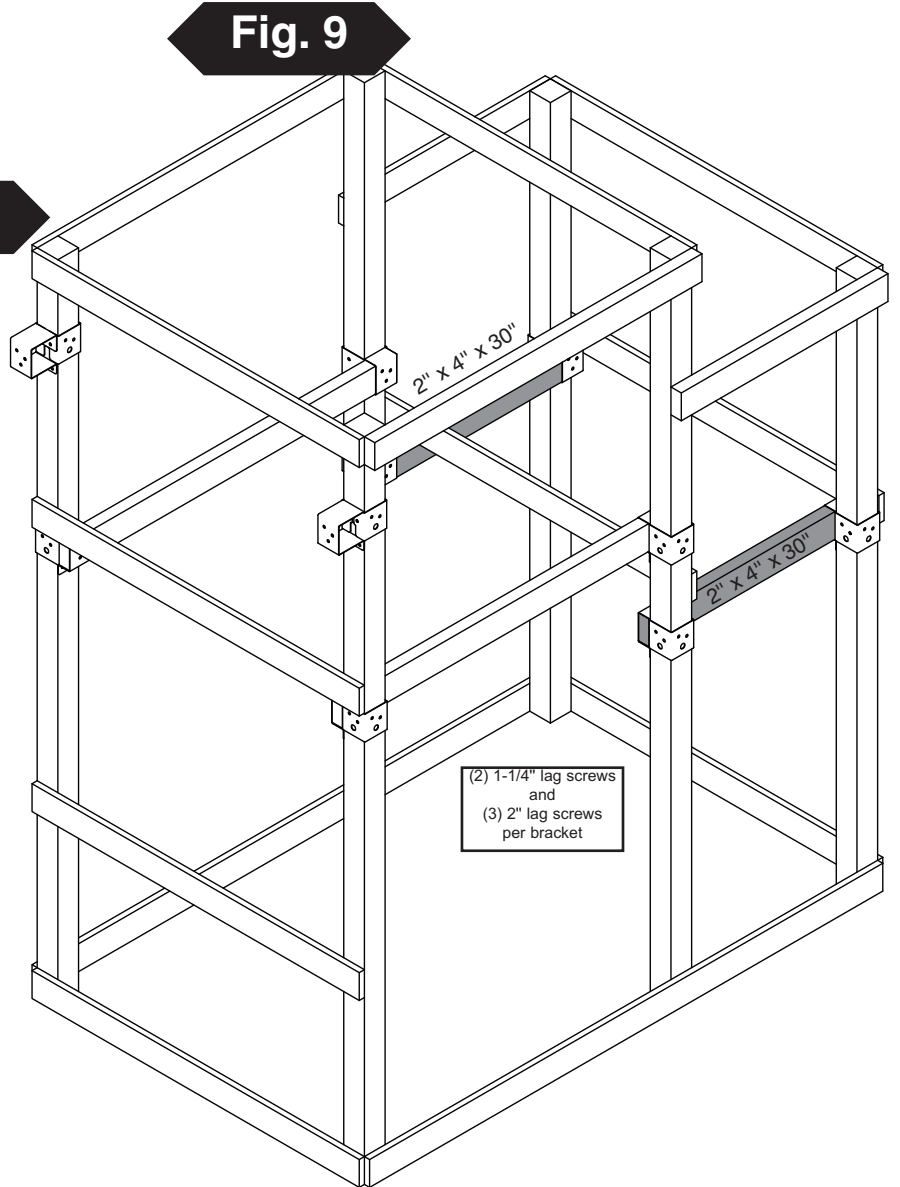
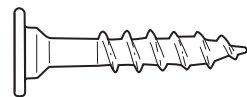
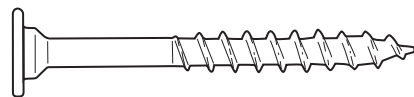

Fig. 9

H. Install 2x4s
 1. Install 2" x 4" as shown in (Fig. 9), (Fig 10), and (Fig. 10a).



1-1/4" Lag screw



2" Lag screw

Fig. 11

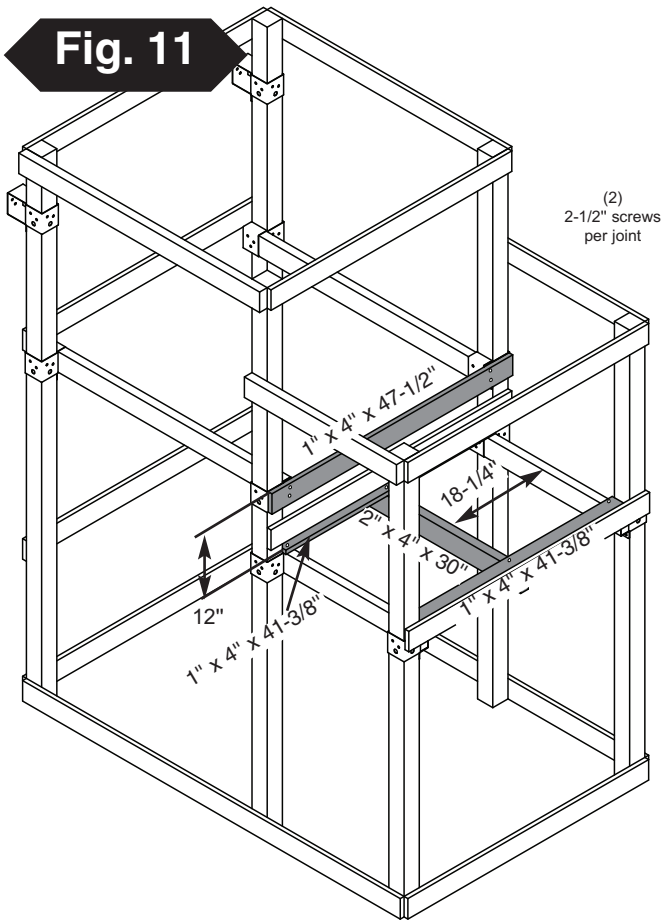

(2)
2-1/2" screws
per joint

Fig. 11a

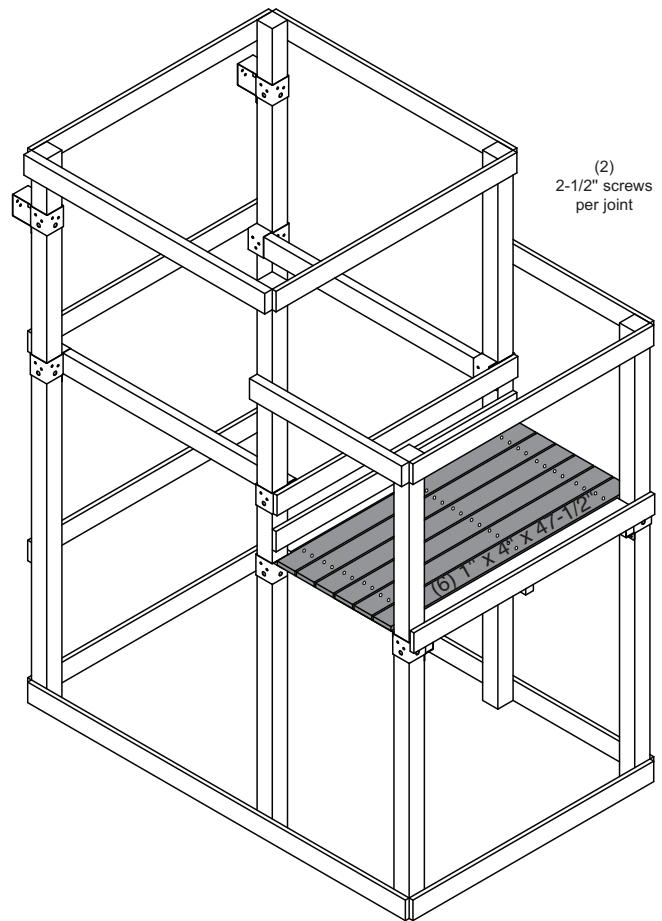

(2)
2-1/2" screws
per joint

NOTE: There must be a 1/2" Nominal Gap between all deck boards.

H. Lower Deck Boards

1. Install 1" x 4" deck boards as shown in (Fig. 11).
2. Install (2) Deck Spacer Board as shown in (Fig. 11).
3. Install (6) Deck Boards as shown in (Fig. 11a).



2-1/2" screw

Fig. 12

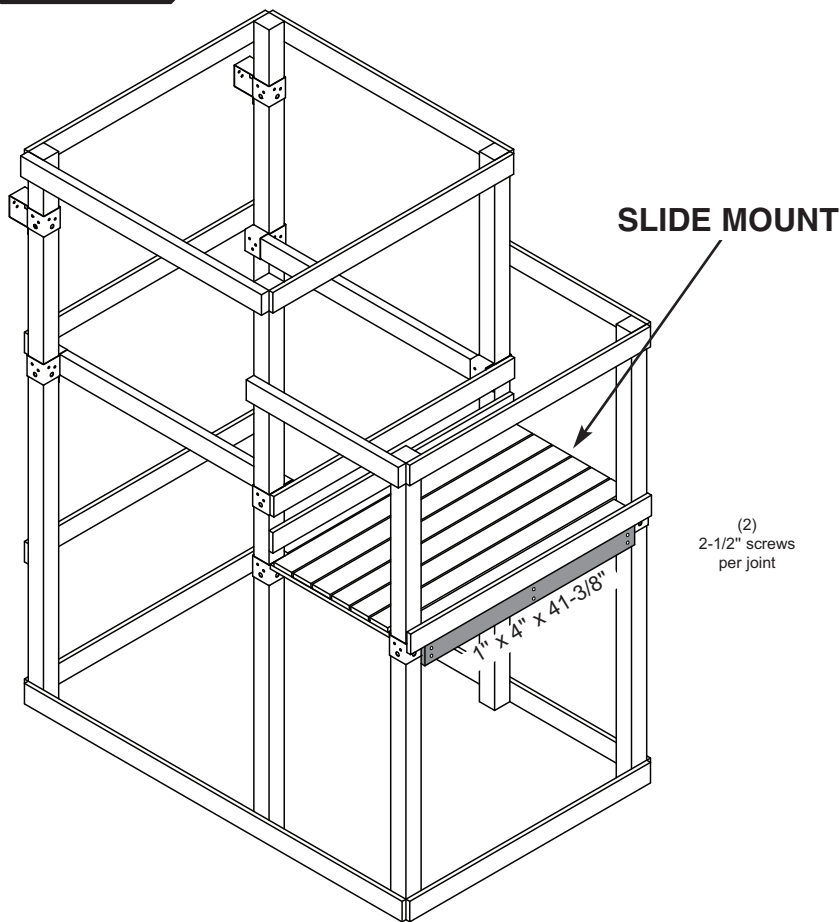

(2)
2-1/2" screws
per joint

Fig. 12a

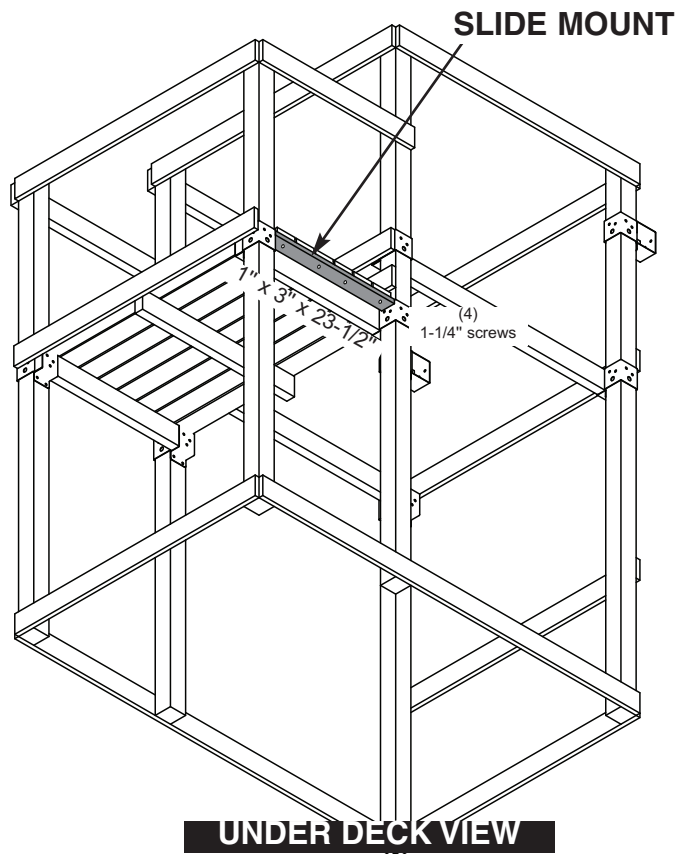

1-1/4" screw



2-1/2" screw

I. End Cap Boards

1. Attach 1" x 4" End Cap boards as shown in (Fig. 12), (Fig 12a).

Fig. 13

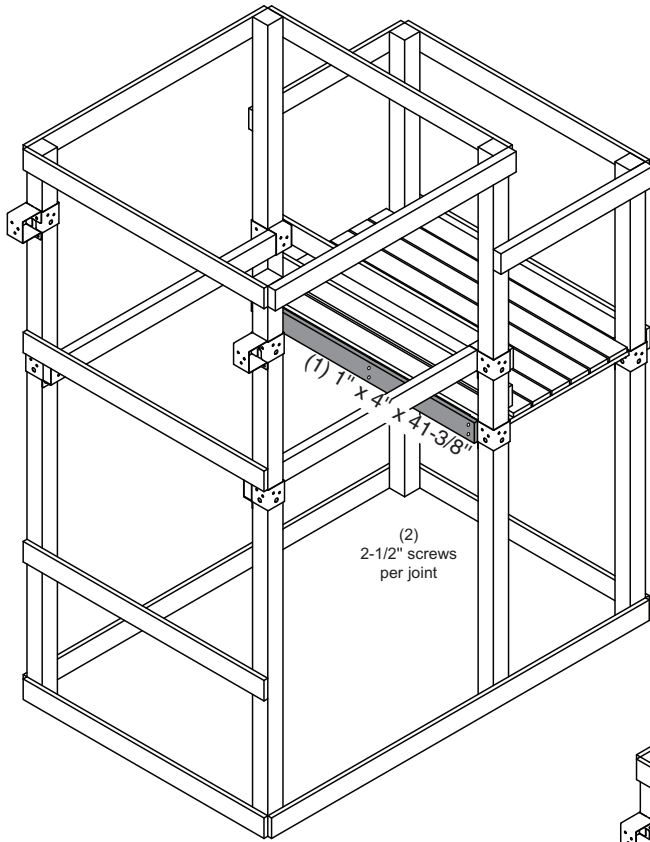
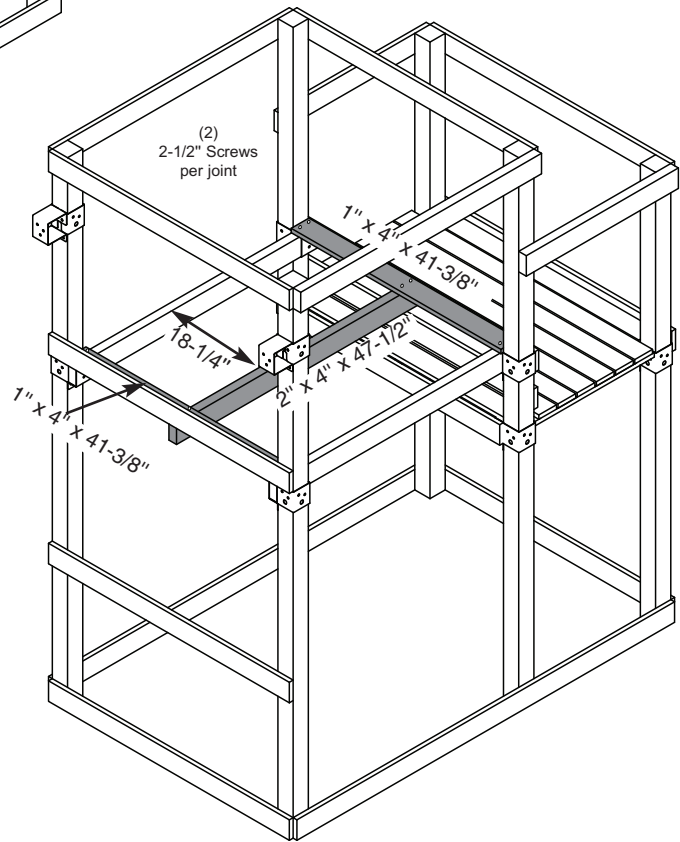

Fig. 13a



Install Deck and Support Boards

1. Install Lower Deck Support Board as shown in (Fig. 13).
2. Install 1" x 4" deck boards and 2" x 4" support board as shown in (Fig. 13a).



2-1/2" screw

Fig. 14

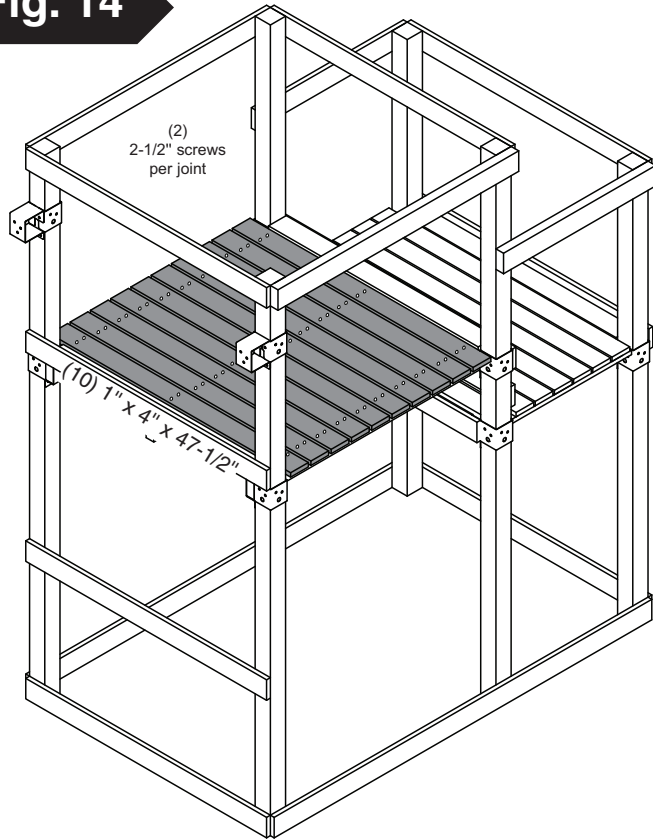

NOTE: There must be a 1/2" Nominal Gap between all deck boards.

J. Install Deck Supports
1. Install (10) 1" x 4" Deck Boards as shown in (Fig. 14).



2-1/2" screw

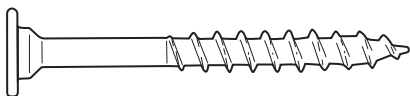
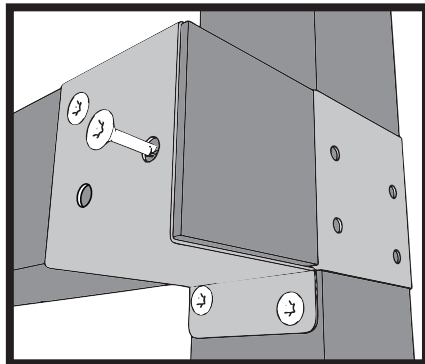

2" Lag screw

Fig. 14a

(5)
2" lag screws
per joint

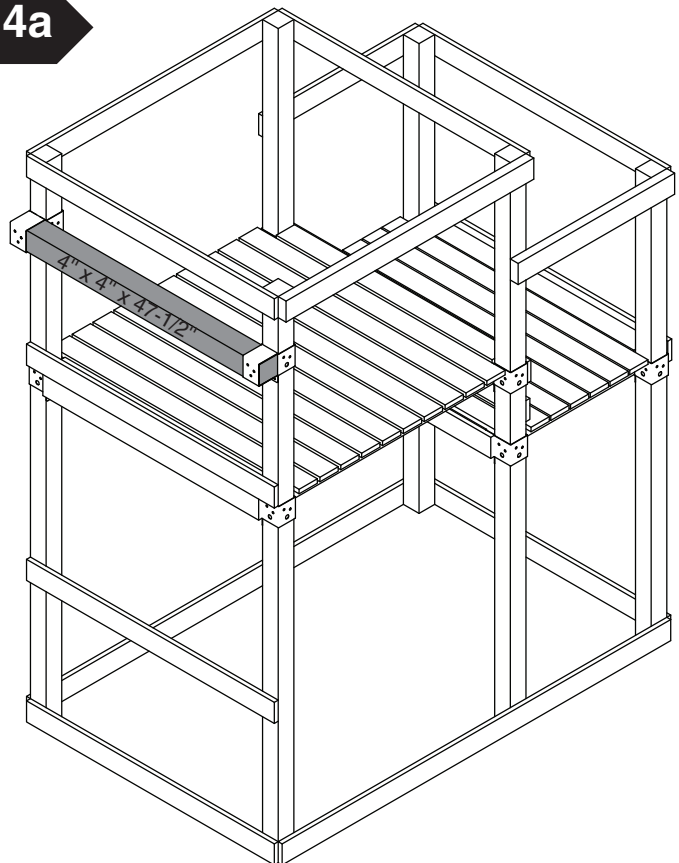

Install Swing Beam Support
1. Install 4" x 4" Swing Beam Support as shown in (Fig. 14a).

Fig. 15

A-FRAME

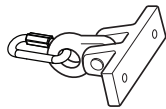
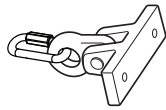
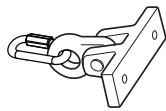
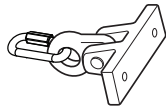

● 3/8" drill location

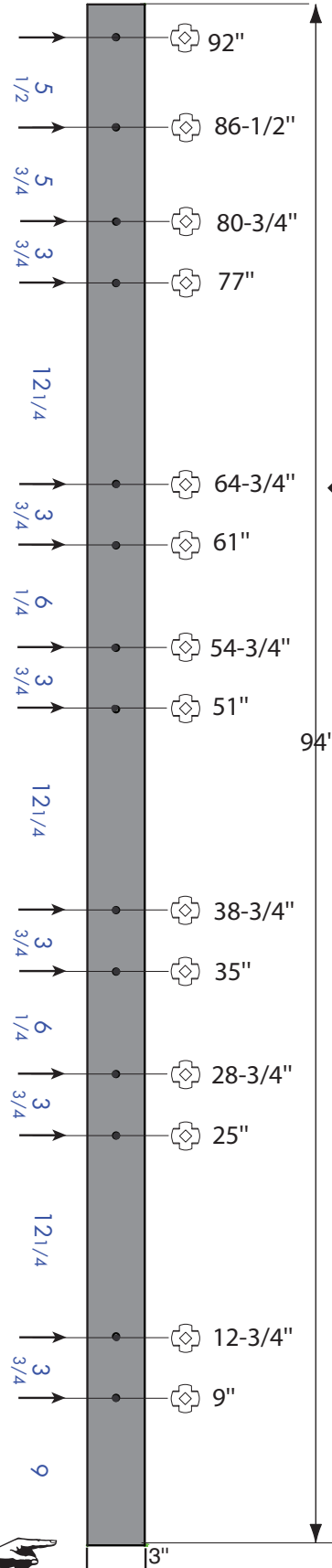

Measure from Here

playset

H. Swing Beam Drill Locations

1. Tap Wood Loc Washer and Carriage Bolt into swing beam at locations shown in **(Fig. 15a)**.

Fig. 15a

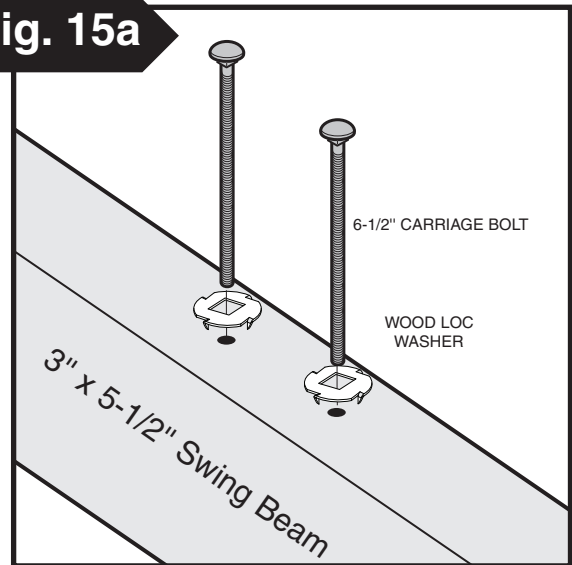
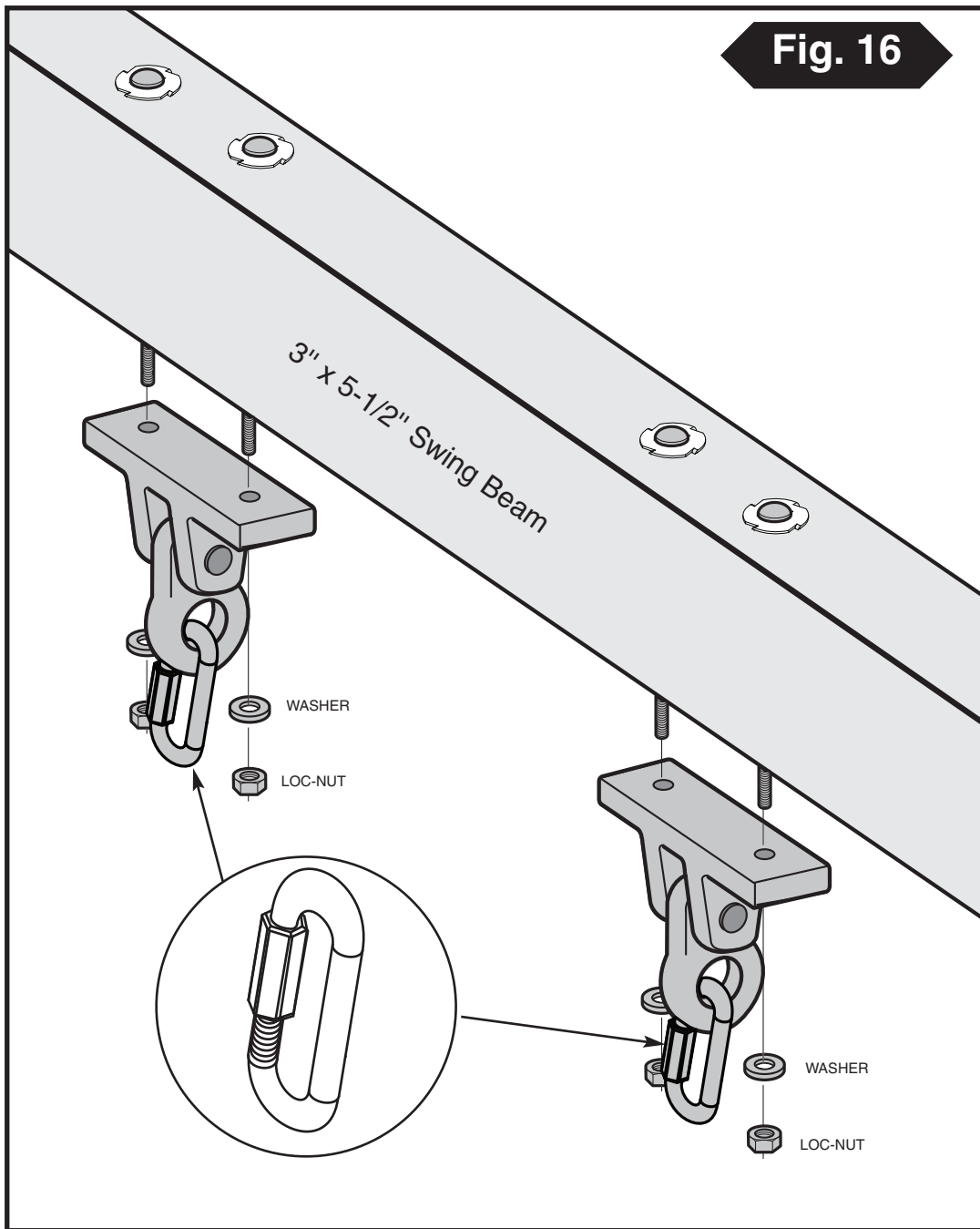

Fig. 16



Q. Swing Beam Drill Locations

1. Flip 3" x 5-1/2" Swing Beam so Carriage Bolts point downward as shown in **(Fig. 16)**.
2. Install the swing hanger onto the beam by sliding over two carriage bolts (refer to **(Fig. 15)** for placement) and apply two washers and two loc-nuts per Swing Hanger. Make certain to orient swing hanger as shown in **(Fig 16)**.
Note: When attaching D-Ring, make certain threads are pointing up. This will help keep the D-Ring from loosening over time.
4. Repeat for all four hangers.

Fig. 17

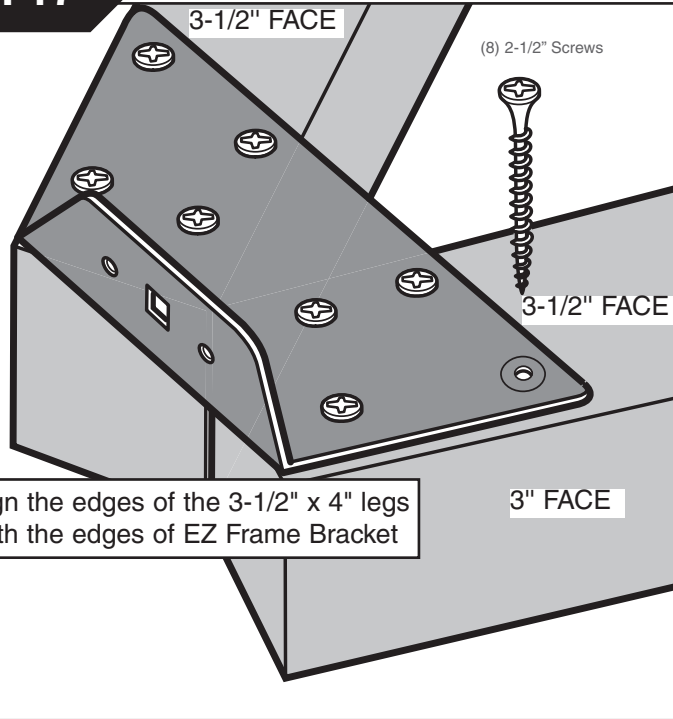

R. A-Frame Assembly

1. layout 3-1/2" x 4"s and 2" x 4" as shown in **(Fig. 17)** and **(Fig. 17a)**.
2. Align EZ Frame Bracket with face of 4" x 4"s.
3. Secure EZ Frame Bracket with (8) 2-1/2" screws to 3-1/2" x 4"s making sure they are flush with each other.
4. Secure 2" x 4" to 3-1/2" x 4"s as shown in **(Fig. 17a)**.
5. Flip over and add 2nd bracket. Repeat steps 2 and 3.

Fig. 17a

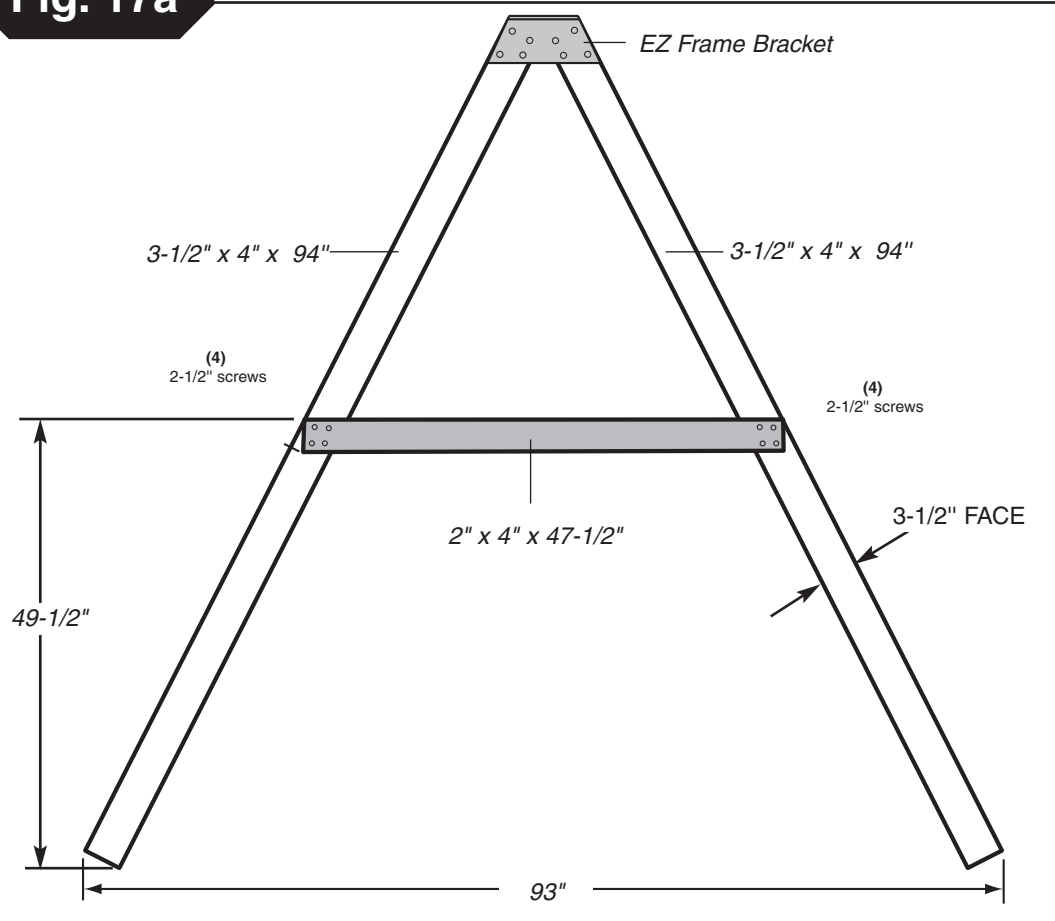

2-1/2" screw



Fig. 18

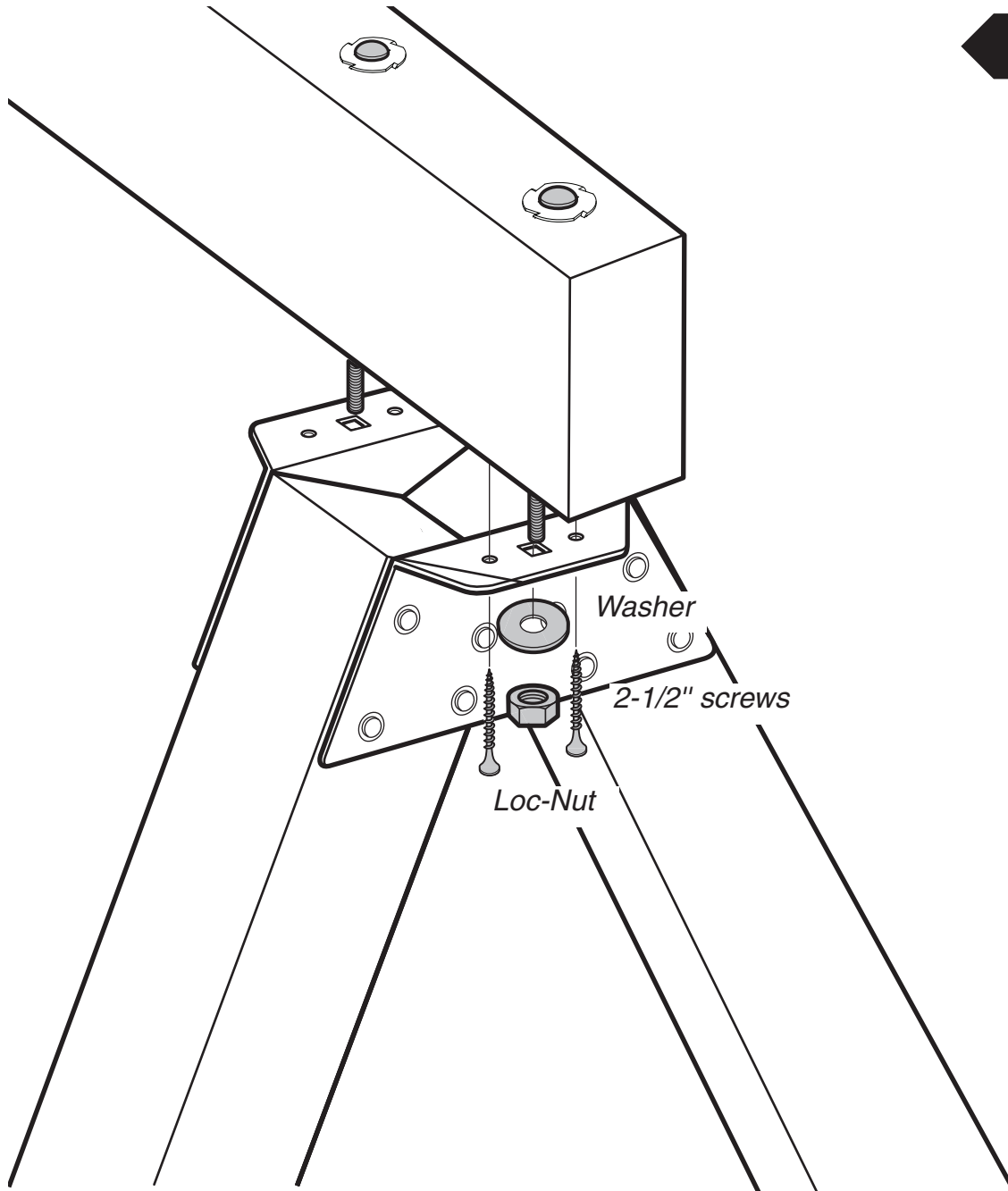

S. A-Frame Assembly cont.

1. Align EZ-Frame Bracket with carriage bolts on Swing Beam as shown in **(Fig. 15)**.
2. Attach A-Frame beam to Swing Beam using (2) washers and (2) Loc-Nuts and 2 screws as shown in **(Fig. 18)**.
3. Tighten Loc-Nut. Repeat on other bracket.

Fig. 19

T. Swing Beam Attachment.

1. Position Split-Brackets on 4" x 4" x 47-1/2" as shown in **(Fig. 19)**.
2. With the help of others, lift A-Frame and Swing Beam Assembly and center onto unit as shown in **(Fig. 19a)**.
3. Secure as shown in **(Fig 19a)**.

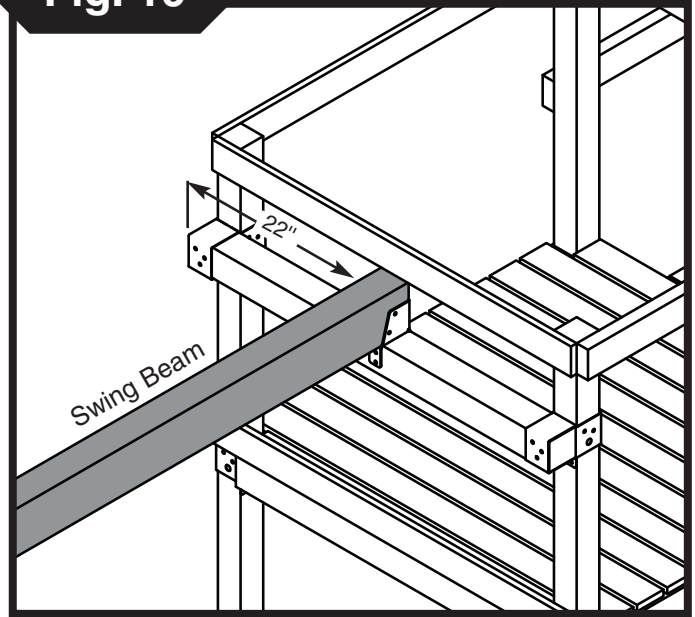
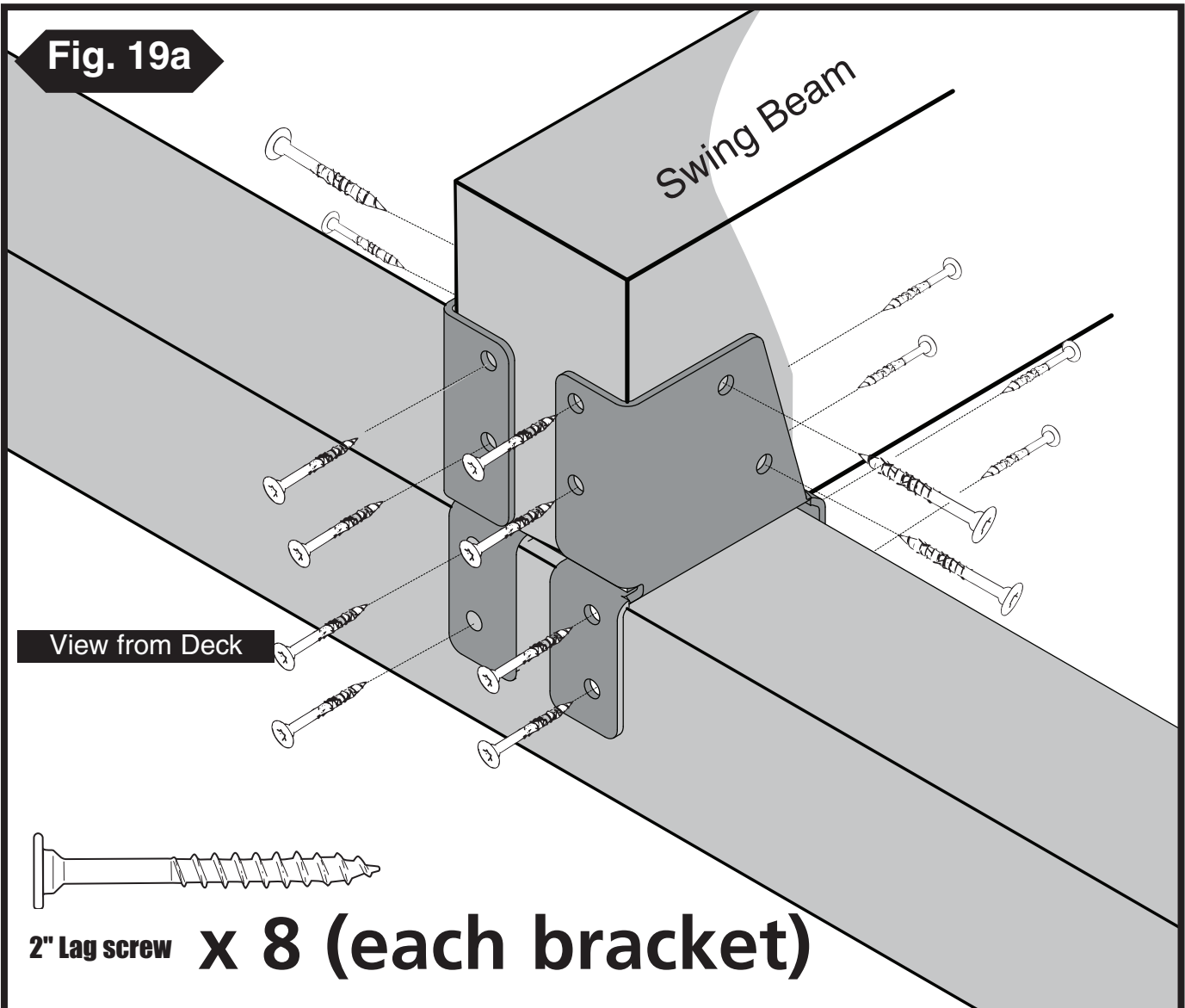
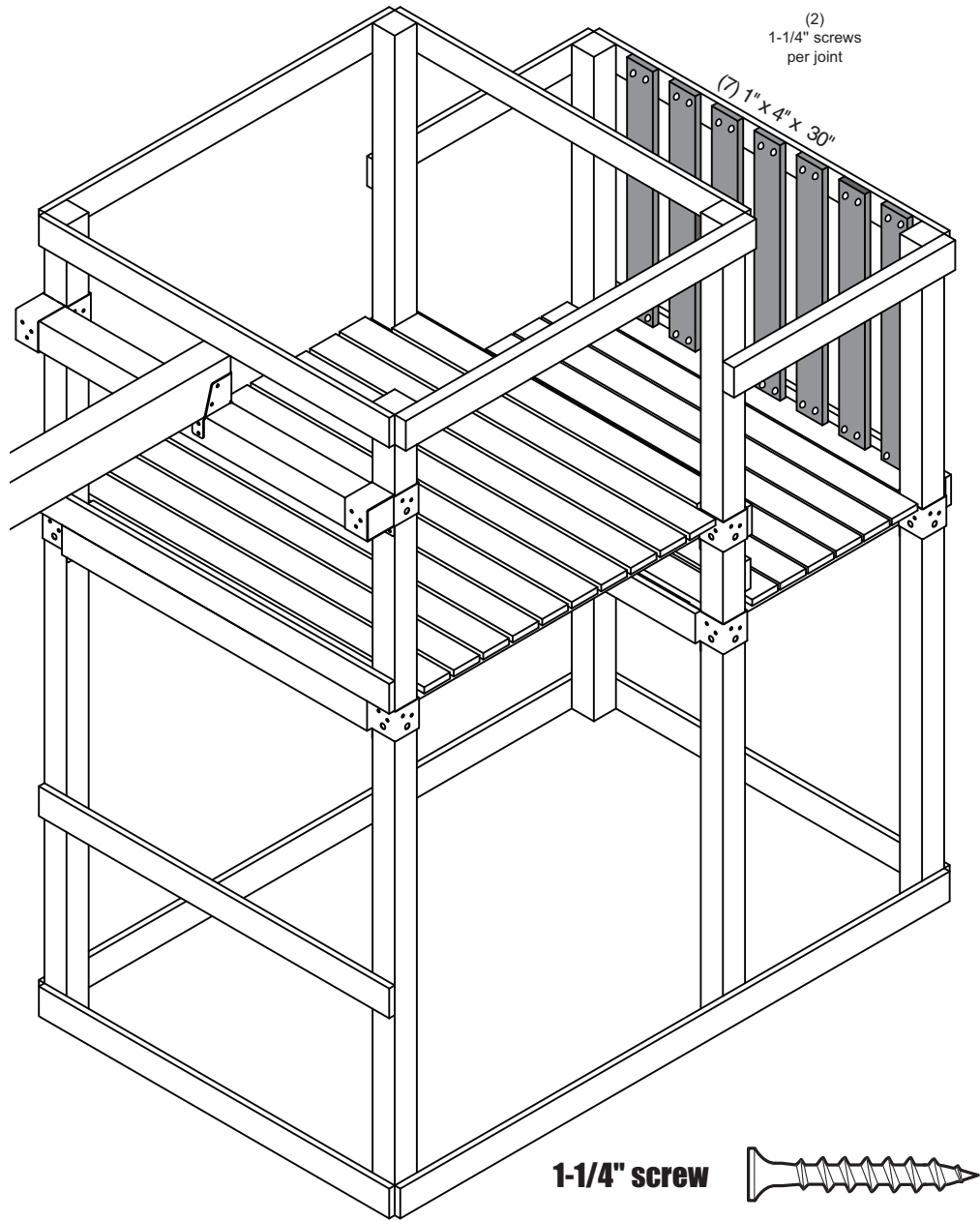

Fig. 19a



NOTE: There must be a 2-1/4" Nominal Gap between all barrier boards.

Fig. 20



Install Barrier Boards

1. Install boards as shown in **(Fig. 20)**. Space boards evenly.

Fig. 21

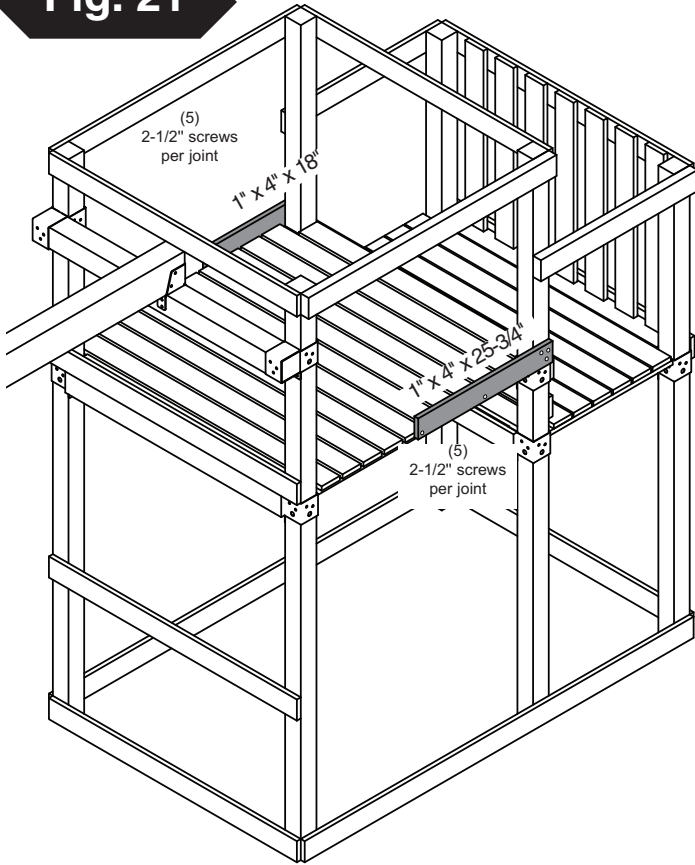

2-1/2" screw

Fig. 22

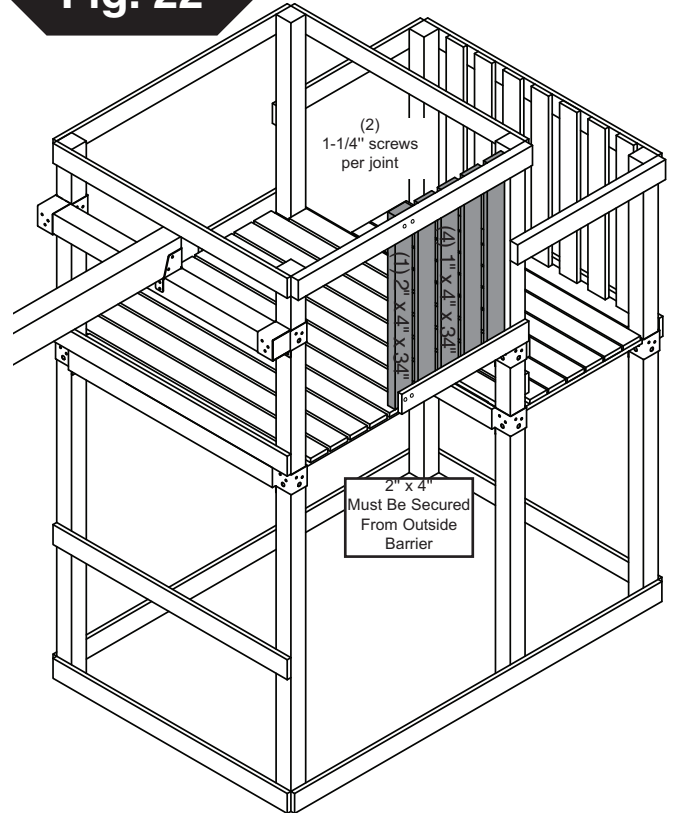

1-1/4" screw

NOTE: There must be a 1" Nominal Gap between all barrier boards.

V. Barrier Boards

1. Install 1" barrier boards as shown.

V. Barrier Boards

1. Install 2" x 4" and 1" x 4" barrier boards evenly spaced as shown in **(Fig. 22)**.

Fig. 23

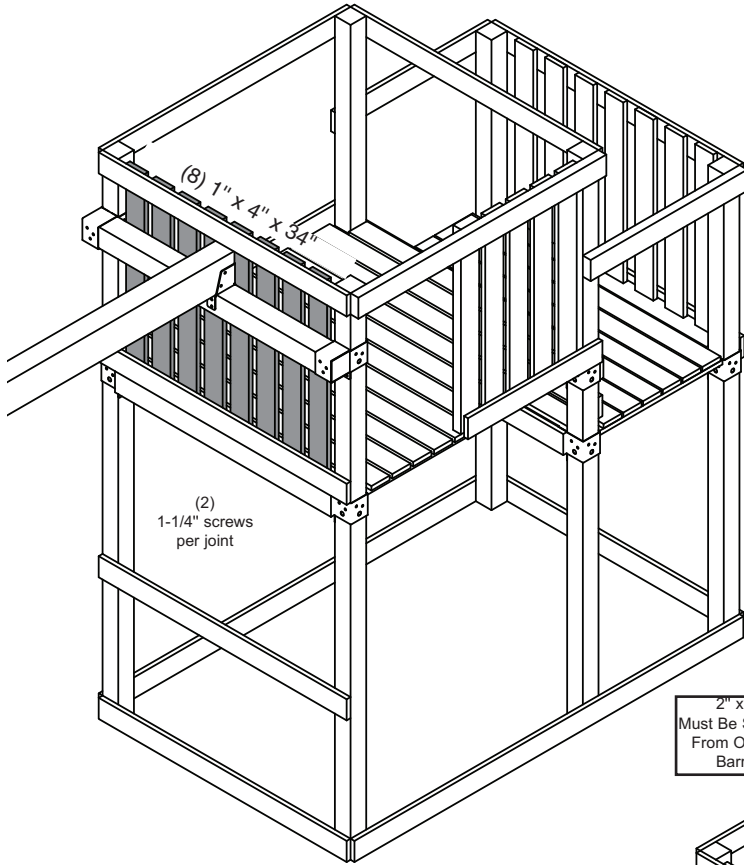

NOTE: There must be a 1-1/2" Nominal Gap between all barrier boards.

Fig. 24

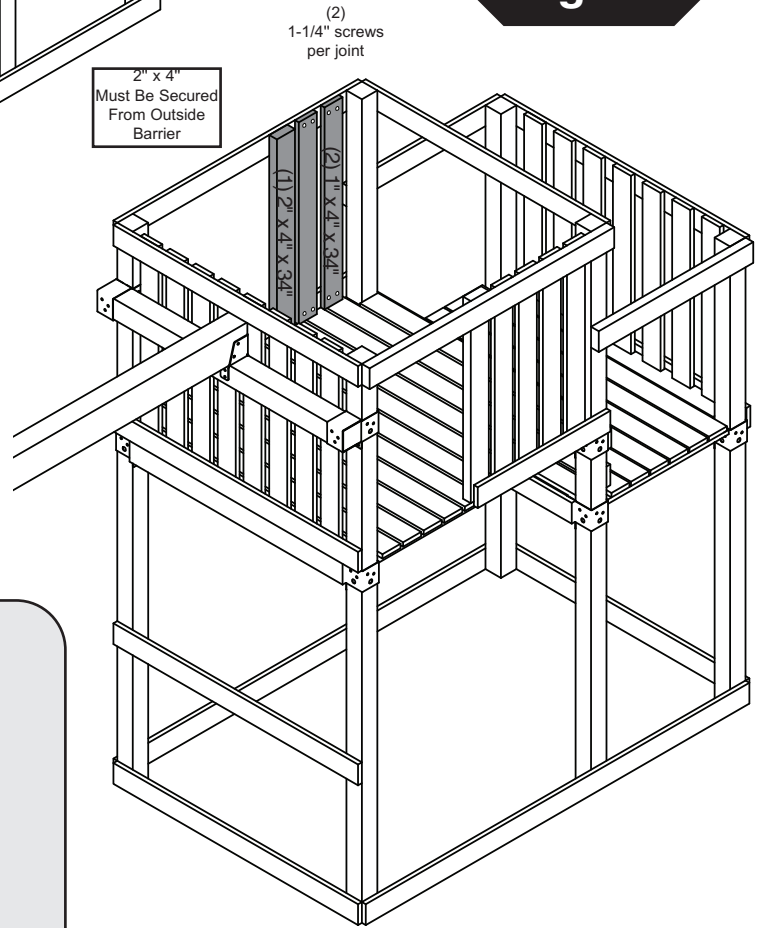

1-1/4" screw



V. Barrier Boards

1. Install barrier boards evenly spaced as shown in **(Fig. 23)**.
2. Install barrier boards as shown in **(Fig. 24)**.

Fig. 25

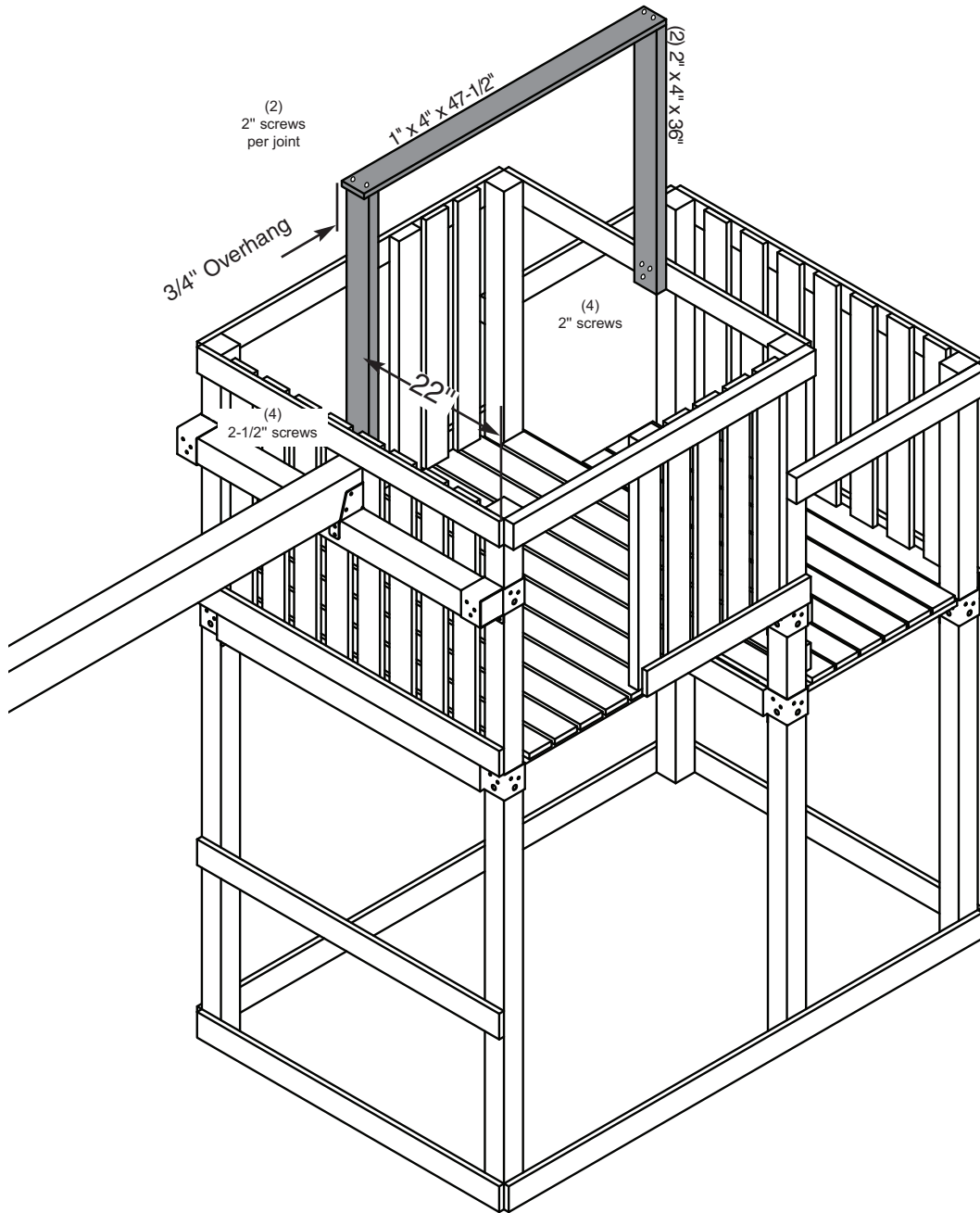

2" screw



2-1/2" screw



V. Taro Support Boards

- 1.** Install 2" x 4" and 1" x 4" tarp support boards as shown in **(Fig. 25)**.

Fig. 26

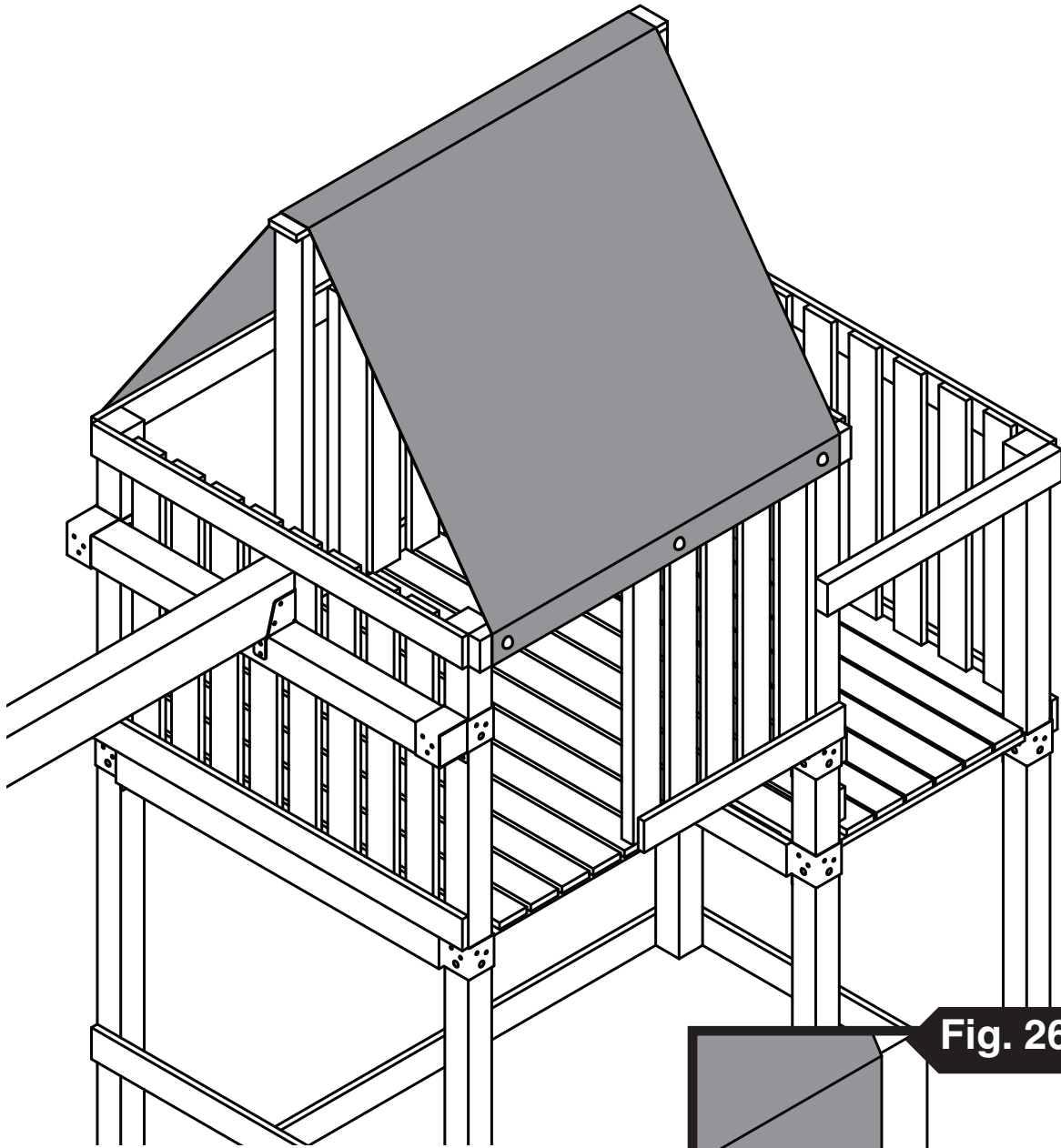

3/4" screw

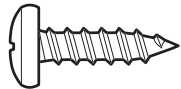

Y. Install Tarp.

- 1.** Install tarp as shown in **(Fig. 26)**.
- 2.** Secure tarp in six locations **(Fig 26a)**.

Fig. 26a

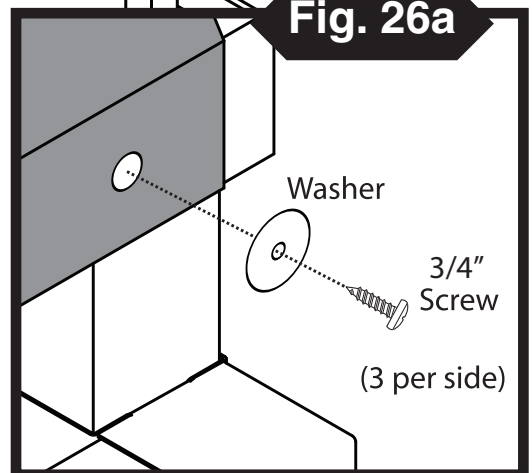

Washer

3/4" Screw

(3 per side)

Fig. 27

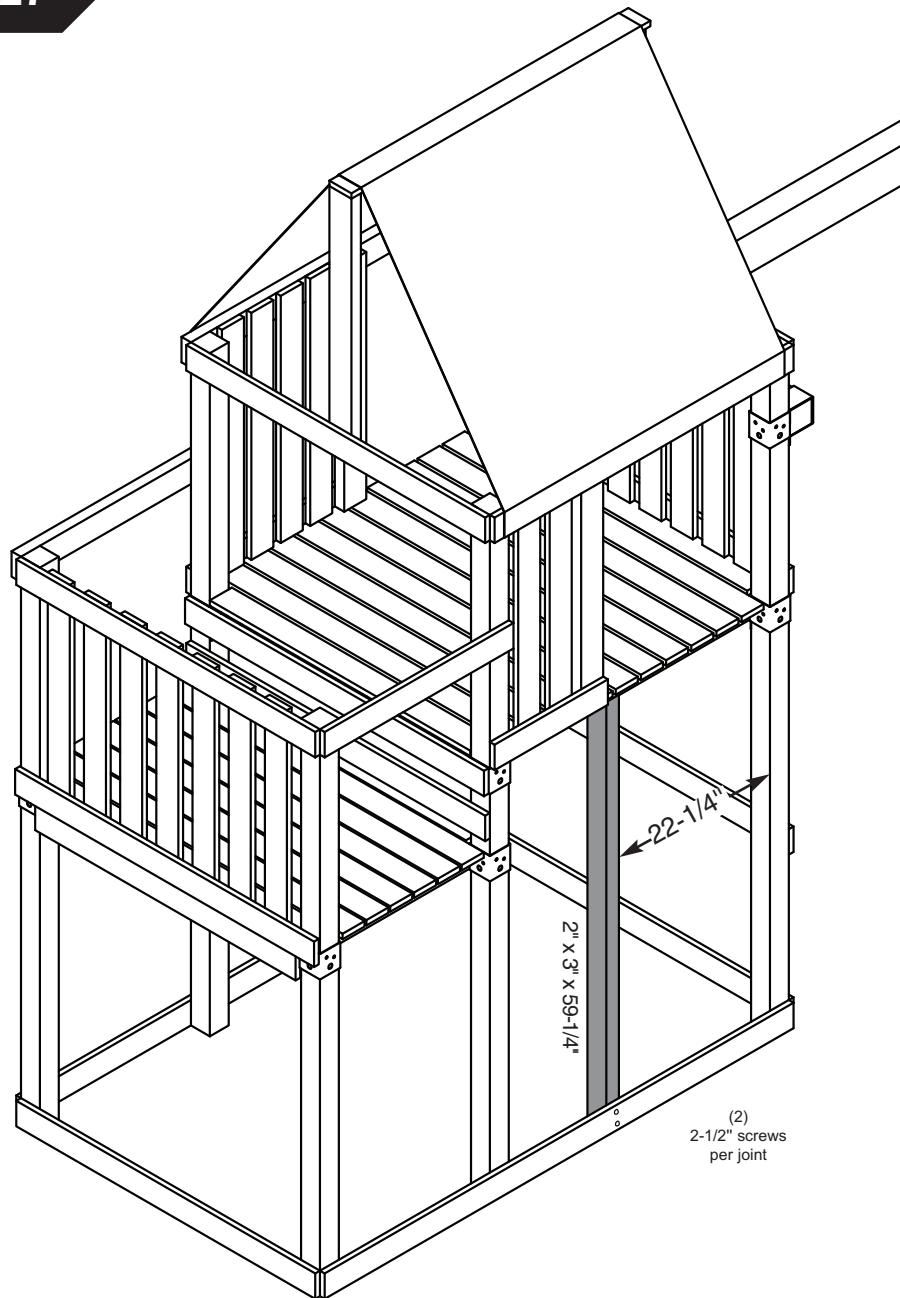

2-1/2" screw



V. Climbing Wall Support Board

1. Install 2" x 3" Climbing Wall support board as shown in **(Fig. 27)**.

Climbing Wall.

1. Attach (14) 1" x 4" boards to (2) 2" x 4" boards and install on unit as shown in **(Fig. 28)**.
2. Attach (1) 2" x 4" board as shown in **(Fig. 28)**.
3. Attach Climbing Wall to unit as shown in **(Fig. 28a)**.

NOTE:
5' Climbing Rock Wall will require
8 Climbing Rocks

Fig. 28

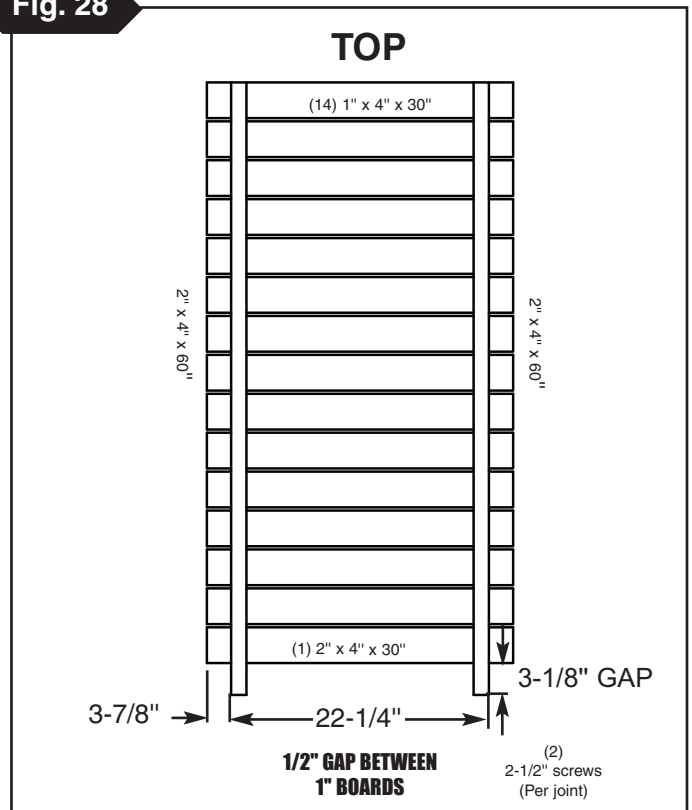

2-1/2" screw

Fig. 28b

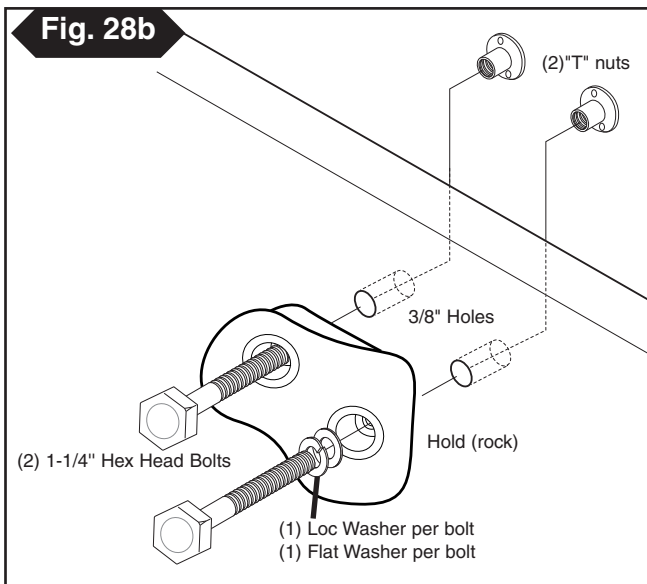
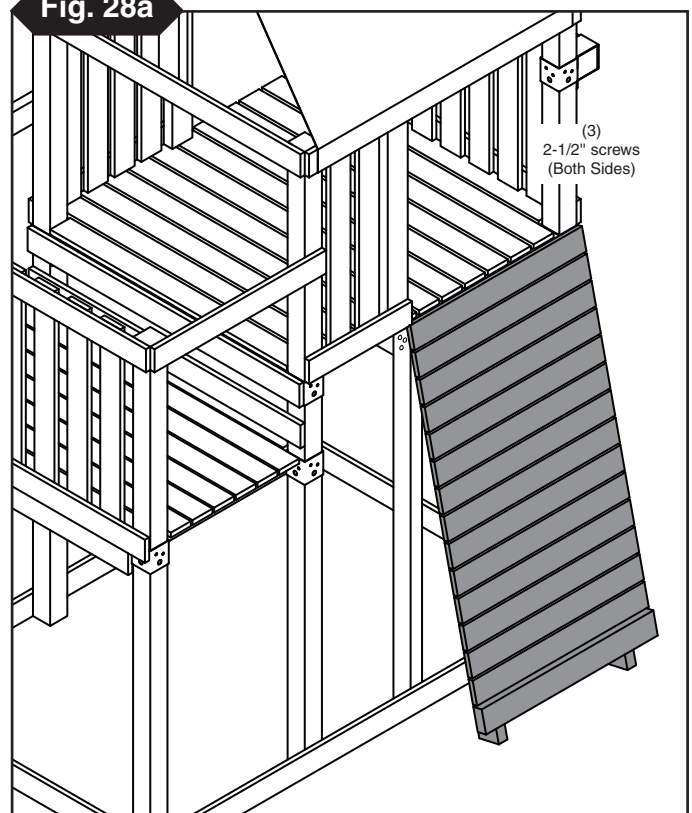

Fig. 28a



Climbing Rock Installation

1. Mark locations of Climbing Rocks on the Climbing Wall in a pattern that will easily allow your child to climb to the deck. Make sure the bolt hole locations are clear of wall supports before drilling.
2. Drill holes through the wall at the desired locations using a 3/8" drill bit. Install Climbing Rocks as shown in **(Fig. 28b)**.
3. Make sure the Climbing Wall and Climbing Rock connections are secure before allowing any children to play on the Climbing Wall.

Fig. 29

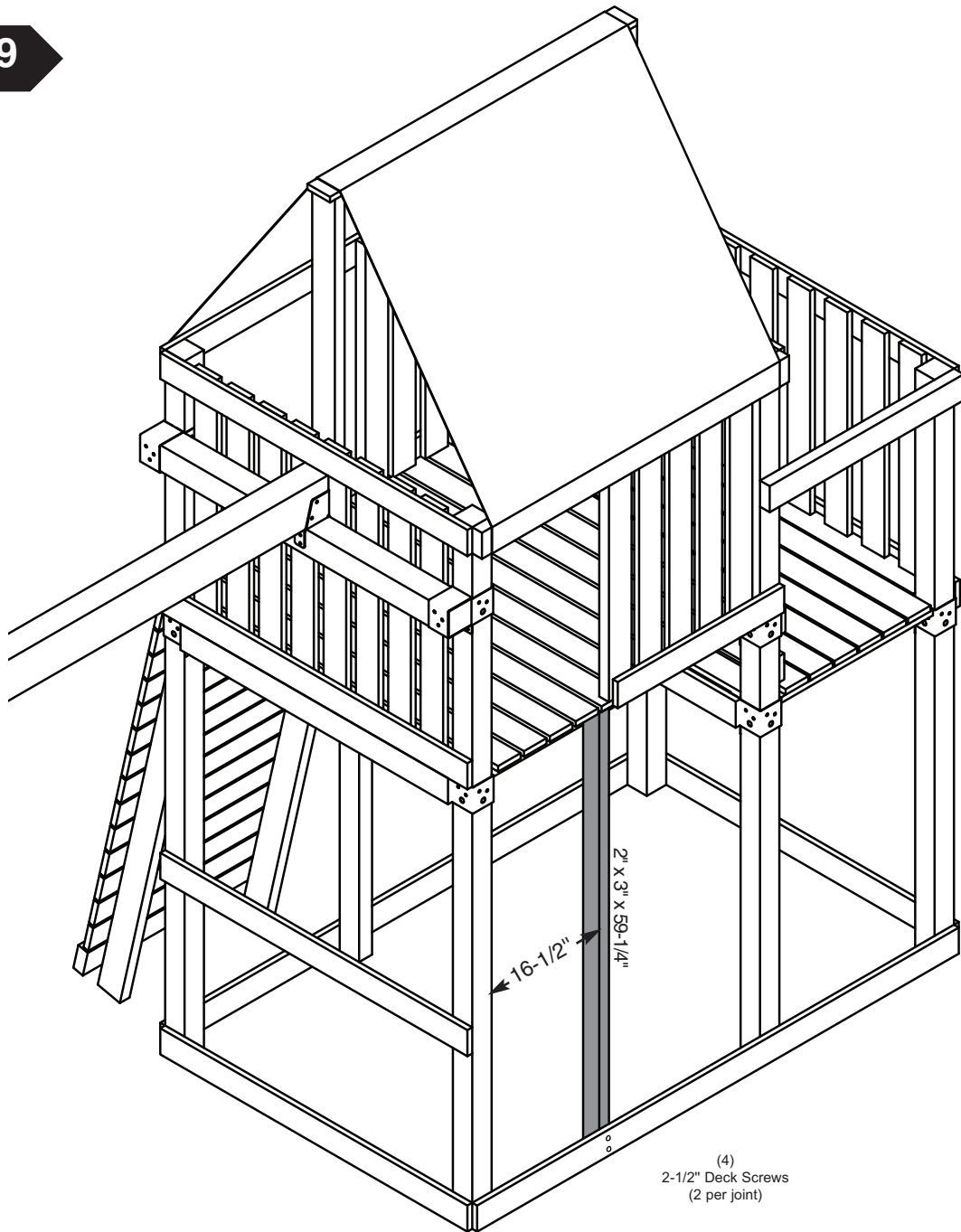

2-1/2" screw



Rung Ladder Support

1. Install 2" x 3" Rung Ladder Support as shown in **(Fig. 29)**.

Fig. 30

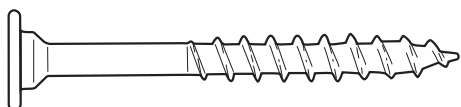
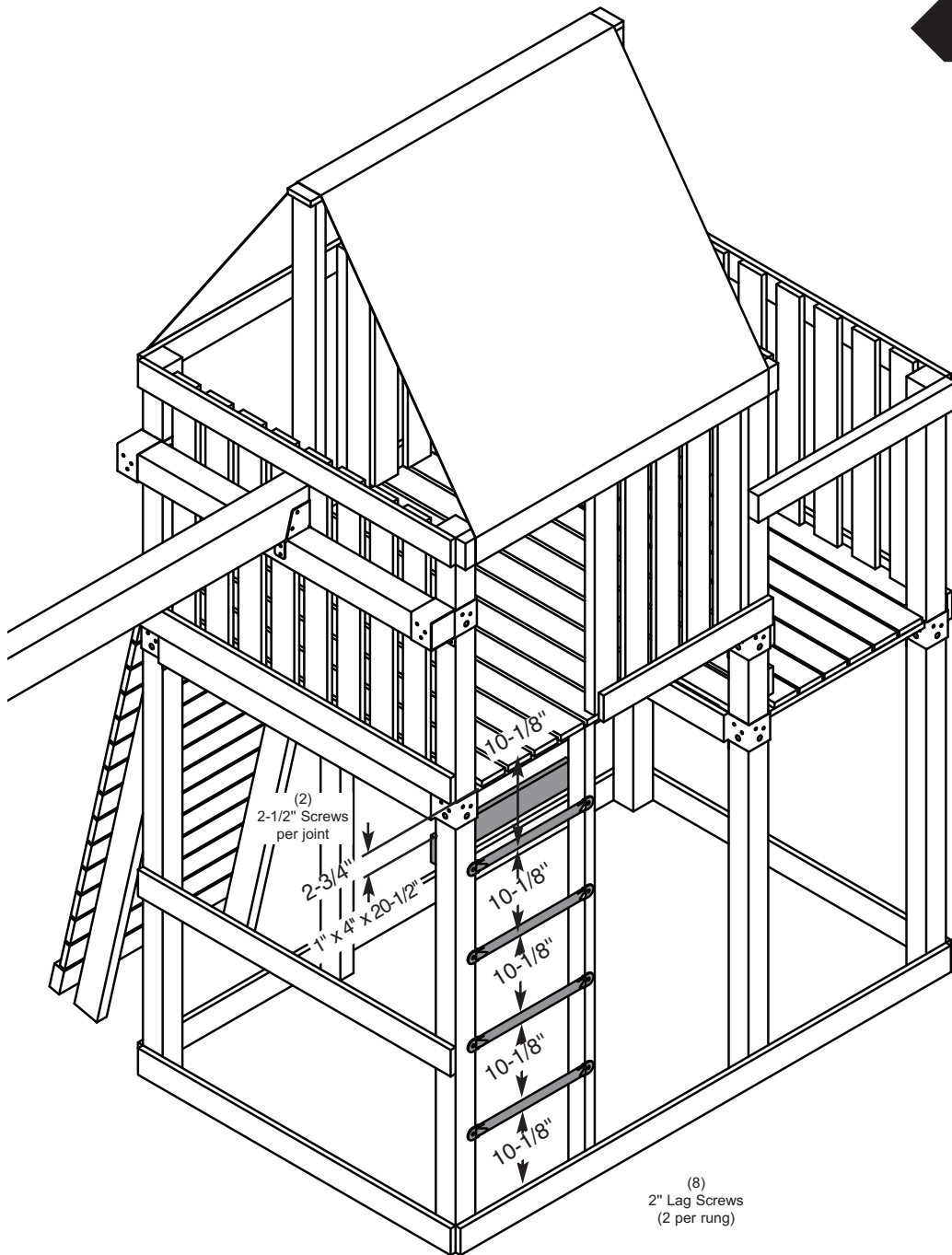

2" lag screw

2-1/2" screw



Rung Ladder

1. Install Ladder Rungs as shown in **(Fig. 30)**.
2. Install 1" x 4" gap filler so that top of board is 2-3/4" below the bottom of the deck support as shown in **(Fig. 30)**.

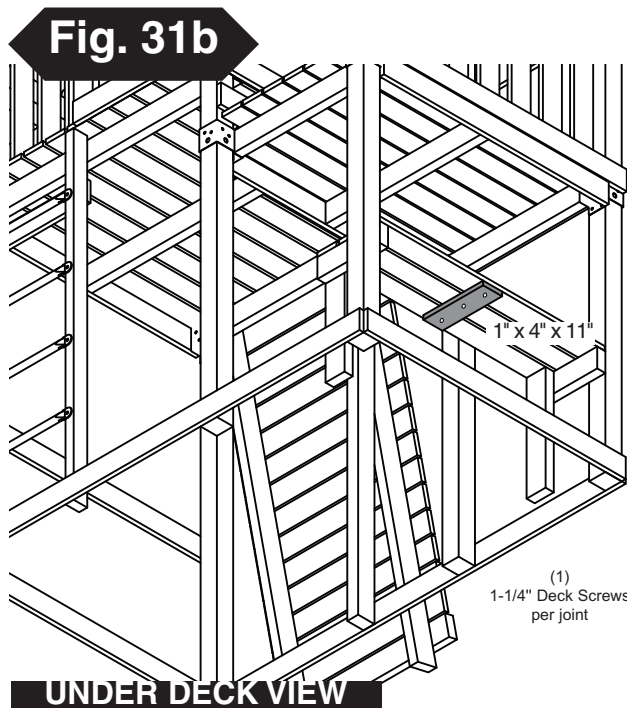
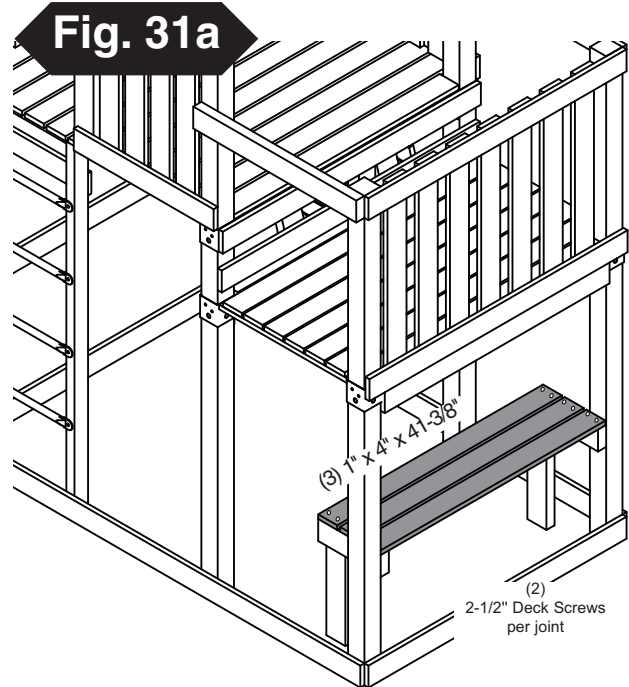
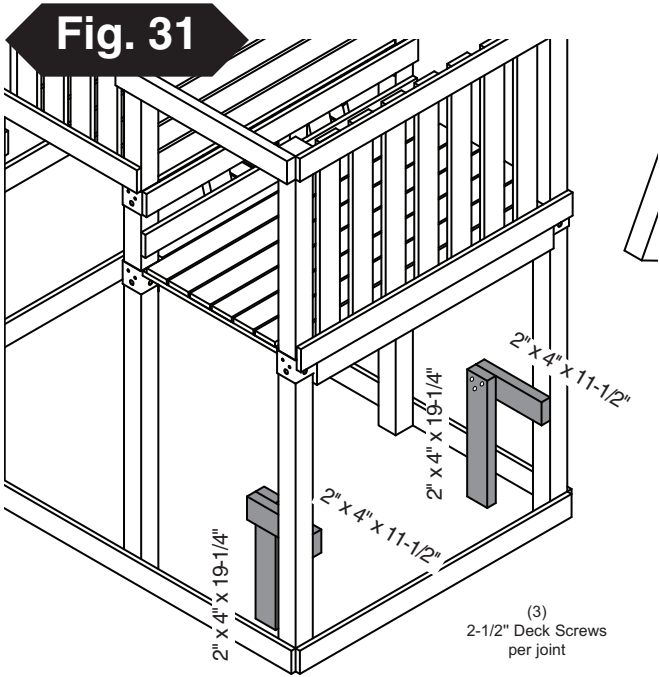

Picnic Table

1. Install 2" x 4" boards as shown in (Fig. 31).
2. Attach 1" x 4" boards as shown in (Fig. 31a). Make certain to evenly space boards.
3. Attach Picnic Table support centered underneath the Picnic table as shown in (Fig. 31b).

UNDER DECK VIEW

Fig. 32

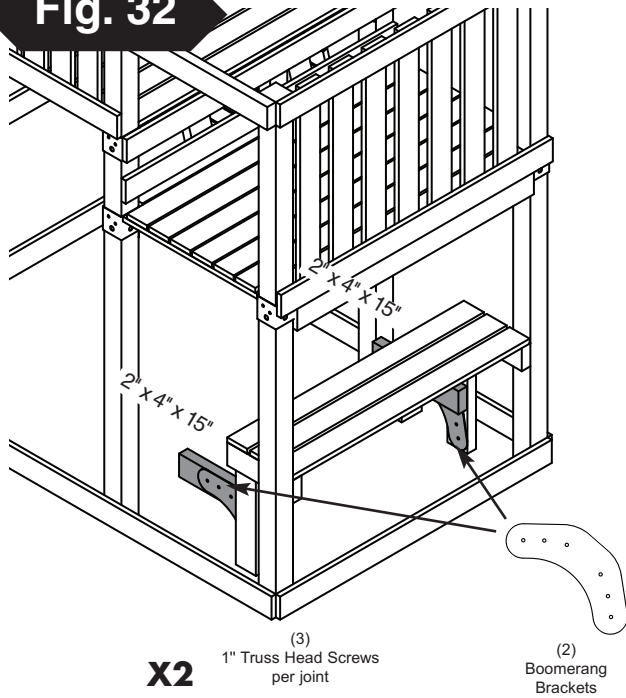
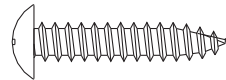
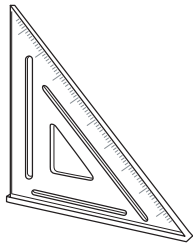
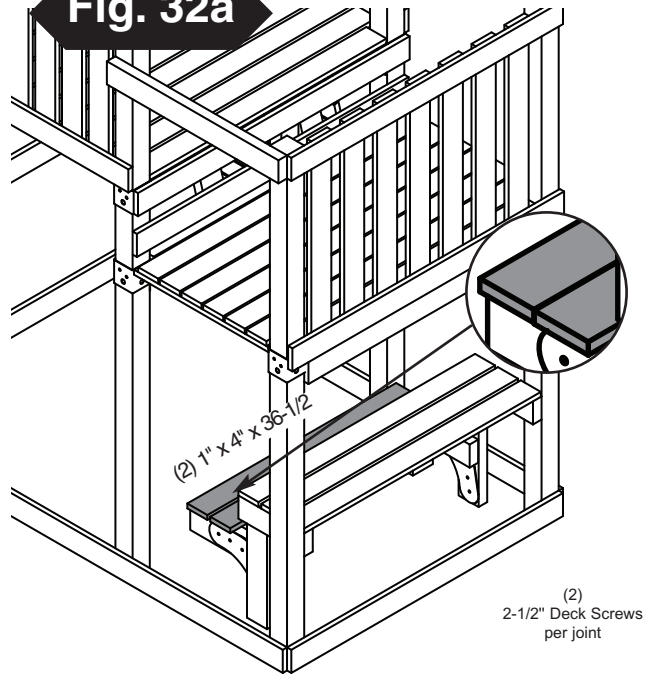

Fig. 32a



1" Truss Head screw

2-1/2" screw



Double check to make sure structure is square

Picnic Bench

1. Using (2) 'Boomerang brackets' Install 2" x 4" boards as shown in **(Fig. 32)**. Sandwich 'Boomerang Bracket' between horizontal and vertical 2" x 4"s. Make certain bottom edge of Boomerang Bracket touches the ground.
2. Attach 1" x 4" boards as shown in **(Fig. 32a)**. Make boards flush with end of 2" x 4" support with no gap inbetween.
3. Attach Picnic Table support centered underneath the Picnic table as shown in **(Fig. 32b)**.

Fig. 32b

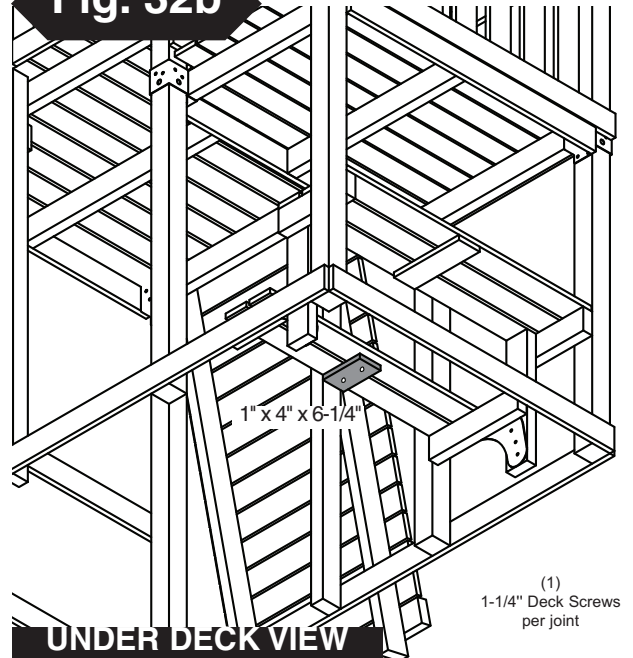

1-1/4" screw



BOARD INVENTORY:

Identify the illustrated boards below to build your Monkey Bars set.

19-1/4"

(2) 2" x 4" x 19-1/4"

60"

(2) 2" x 4" x 60"

94"

(2) 2" x 4" x 94"

Fig. 33

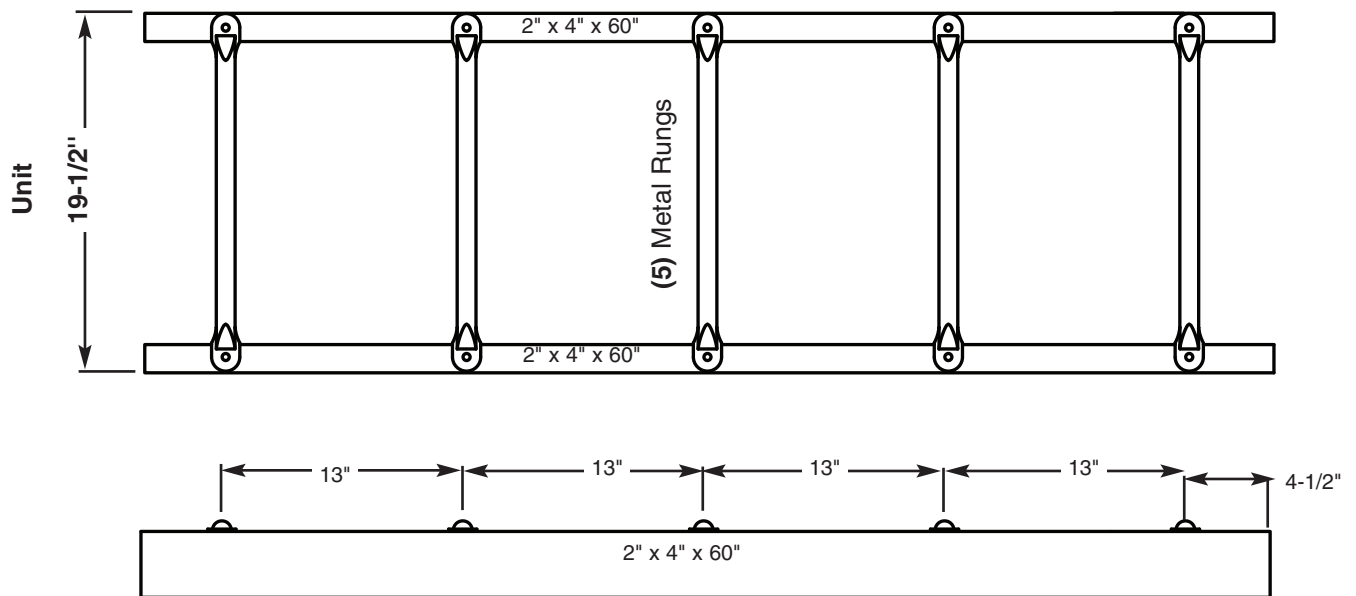

ASSEMBLY INSTRUCTIONS

1. On two 2" x 4" x 60" boards, measure and mark five rung positions, centered at intervals shown in **(Fig. 33)**. Attach Rungs to 2" x 4"s using (2) 2" Lag Screws per rung.

2" Lag screw

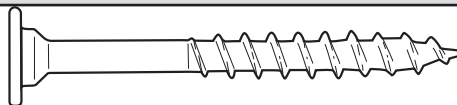

1" Truss Head screw

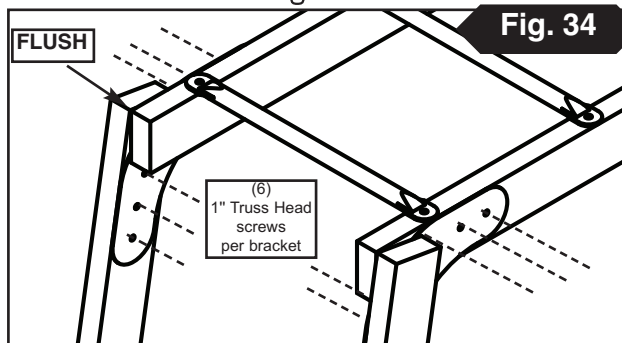
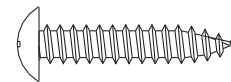

2. Position the 2" x 4" x 19-1/4" steps to the inside of the 2" x 4" x 94" posts as indicated in **(Fig. 35)** and **(Fig. 36)**. Mark the bottom of each step location on the 2" x 4" posts. Attach a step bracket to the posts at each marked location using three 1-1/4" screws per bracket. Place 2" x 4" x 19-1/4" steps on top of brackets and secure using three 1-1/4" screws per bracket.
3. Secure the steps to the ladder posts using (2) 2-1/2" screws per joint as shown in **(Fig. 35)**.
4. Attach Monkey Bars Ladder to Monkey Bars assembly using (2) Boomerang Brackets as shown in **(Fig. 34)**.

Fig. 35

Left Side
2" x 4" x 94"

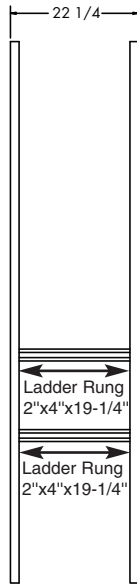
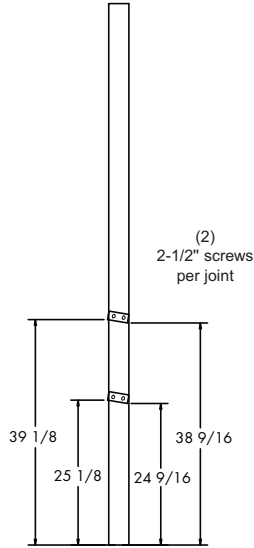

Right Side
2" x 4" x 94"

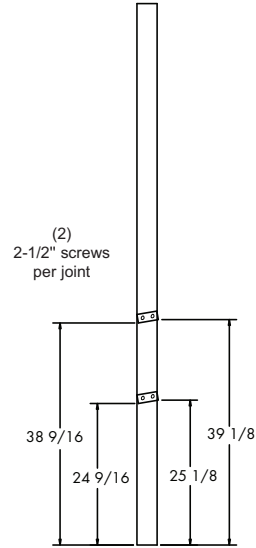

2-1/2" screw



1-1/4" screw



Fig. 36

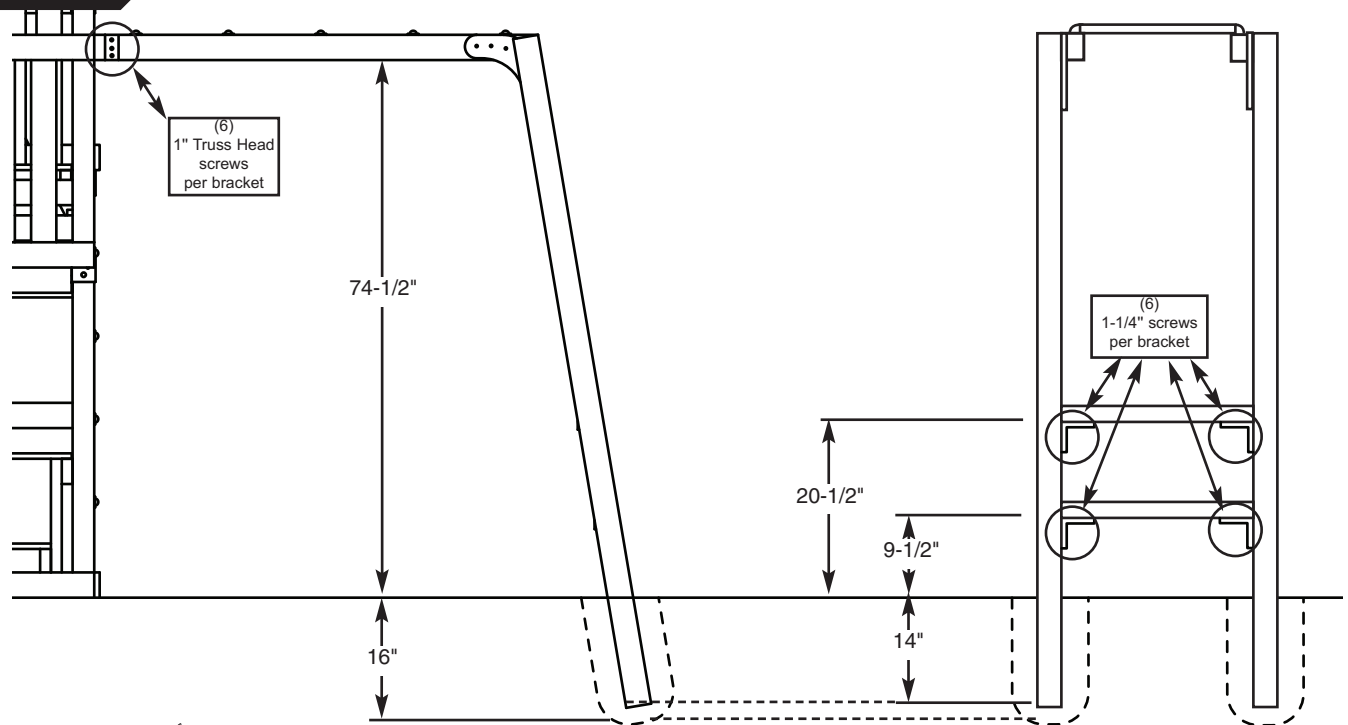

1" Truss Head screw

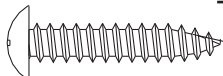

ASSEMBLY INSTRUCTIONS:

5. With the help of others, position the finished assembly to the unit (**Fig. 36**). Determine post locations. remove assembly and dig two 16" deep holes at the previously determined spots. Reposition assembly to unit placing posts in the holes.
6. Level the assembly and attach to the unit using six 1" Truss Head screws per bracket. Fill in holes and compact earth around posts.

Fig. 37

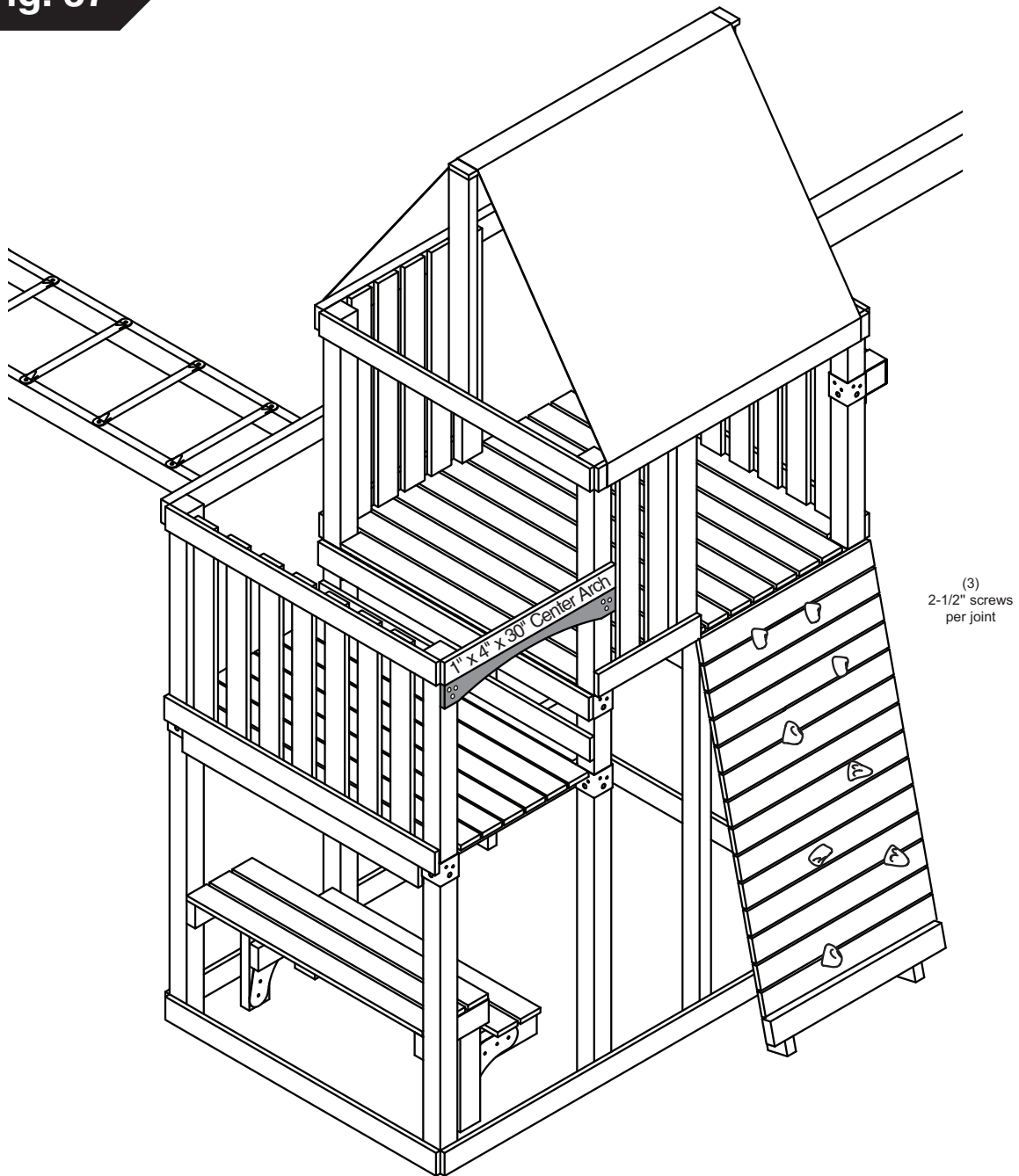

2-1/2" screw



Crowning Arch

1. Install 1" x 4" Arched board as shown in **(Fig. 37)**.

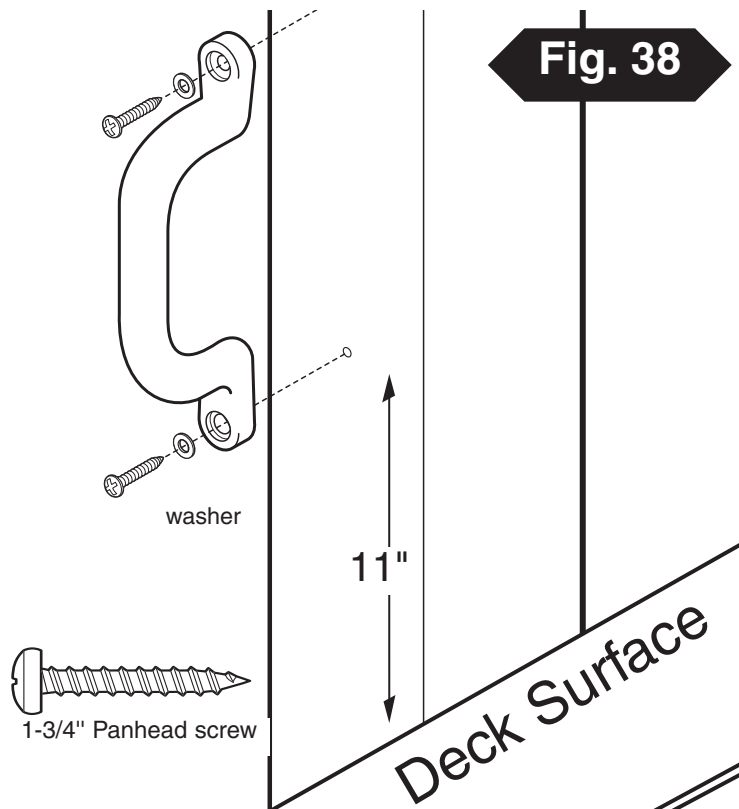

Fig. 38

P. Safety Handles.

1. Mount safety handles in the ladder and climbing wall openings approximately 11" above the deck surface **(Fig. 38)**.

Anchor-It

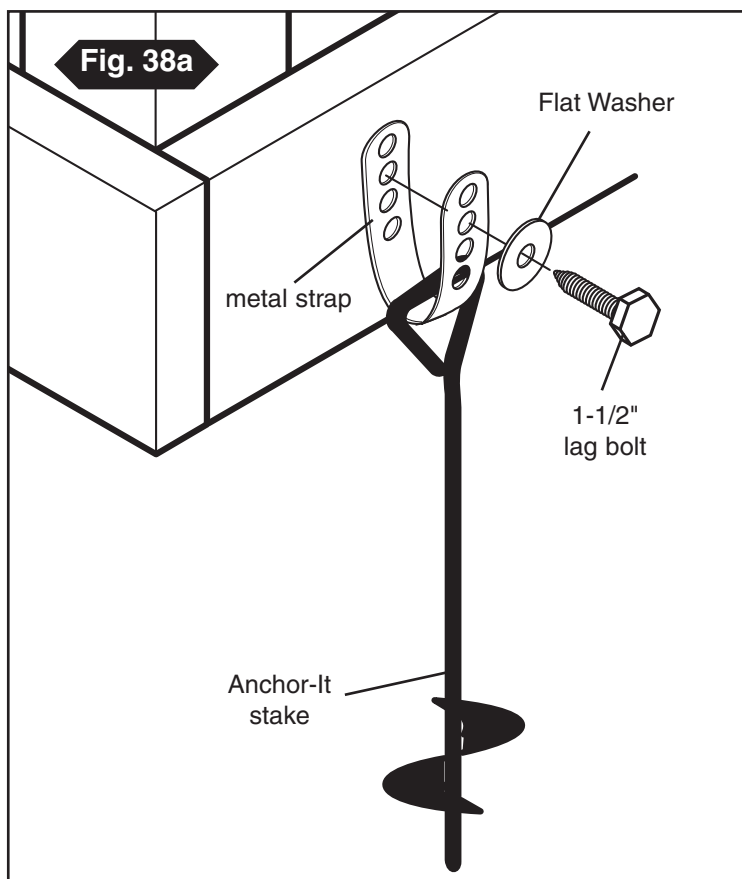

Fig. 38a

S. Anchor-It Installation.

Instructions for Anchoring Swing•N•Slide Activity Centers

1. Determine the final location of your activity center.
2. Place the Anchor-It stakes adjacent to the base and near the corners of your activity center (at the bottom of the legs on swing sets) and twist the auger-style stakes into the ground until only the loop is exposed.
3. Place the metal strap through the loop of the Anchor-It stake and secure it to the unit with a lag screw and washer as illustrated to the right. Note: Attach the strap to the unit with as little play as possible using whatever holes in the strap that work best.

Fig. 39

W. Slide Installation.

1. Install Slide centered in the provided opening as shown in **(Fig. 39)**.
2. Attach Stake to end of slide as shown in **(Fig. 39a)**.

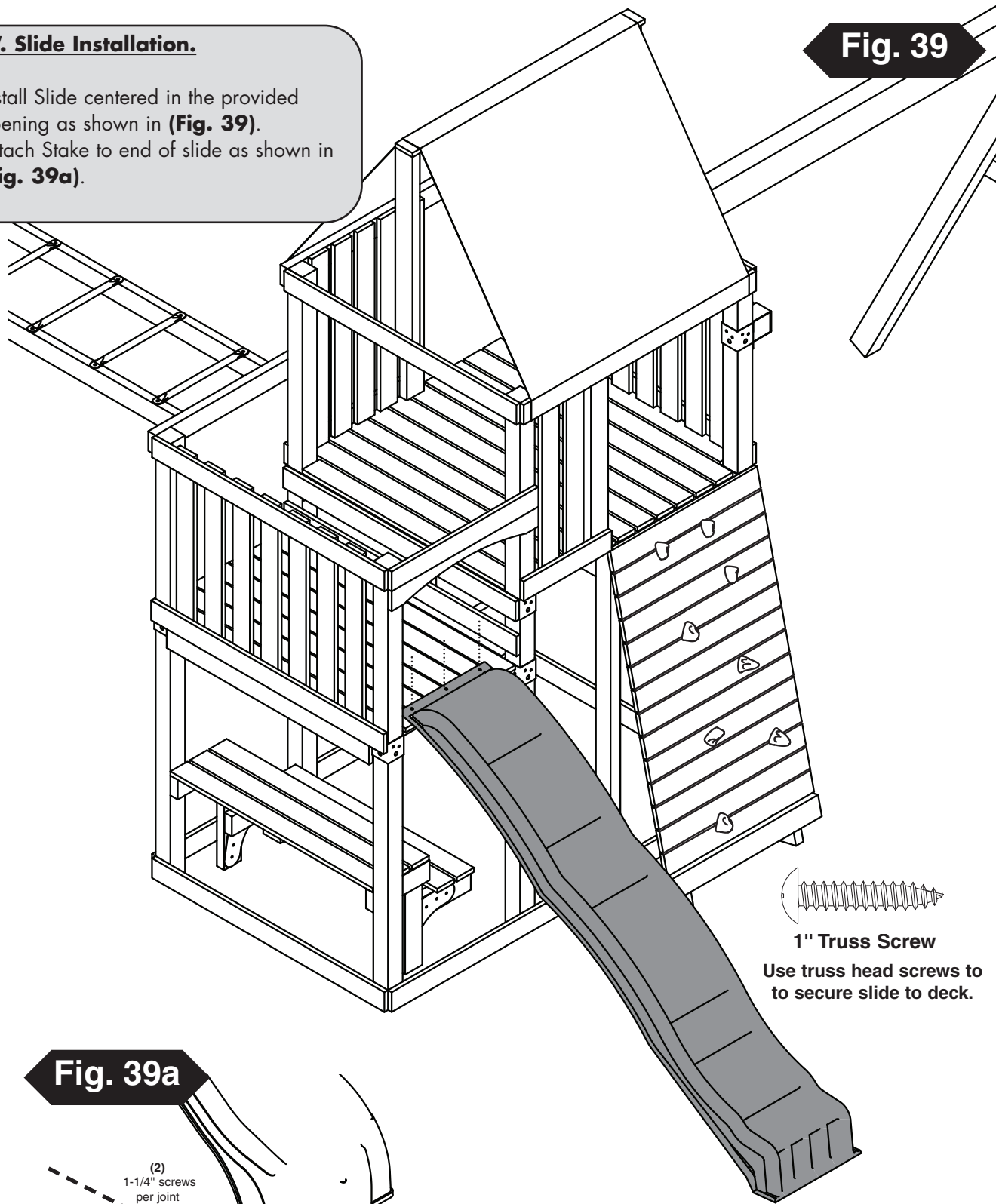

Fig. 39a

