

SEATING PLAN

SCALE: 3/8"=1'-0"

NET SEATS = 20

LOCAL CODES AND SPECIFICATIONS WILL VARY FROM REGION TO REGION AND WILL ALSO CHANGE OVER TIME. IT IS THE BUYER'S RESPONSIBILITY TO CHECK LOCAL CODES FOR COMPLIANCE.

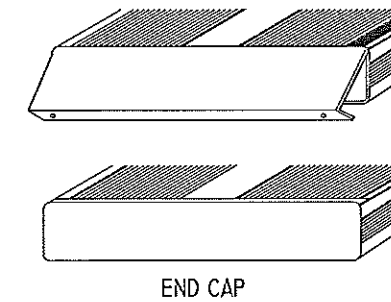

1. LOCATE THE CHANNEL END CAP AS SHOWN, WITH THE WIDER FLANGE ON BOTTOM.

2. TAP THE CHANNEL INTO PLACE WITH A RUBBER Mallet OR SOFT WOOD.

3. DRILL (2) No.8 x 3/4" TEK SCREWS THRU END CAP AND BOTTOM FLANGE OF PLANK

4. ENDCAPS WITH STICKERS ARE TO GO AT ENDS OF SEAT PLANKS, PLAIN ENDCAPS GO ON ALL OTHER BOARDS.

ENDCAP INSTALLATION DETAIL

SCALE: 3" = 1'-0"

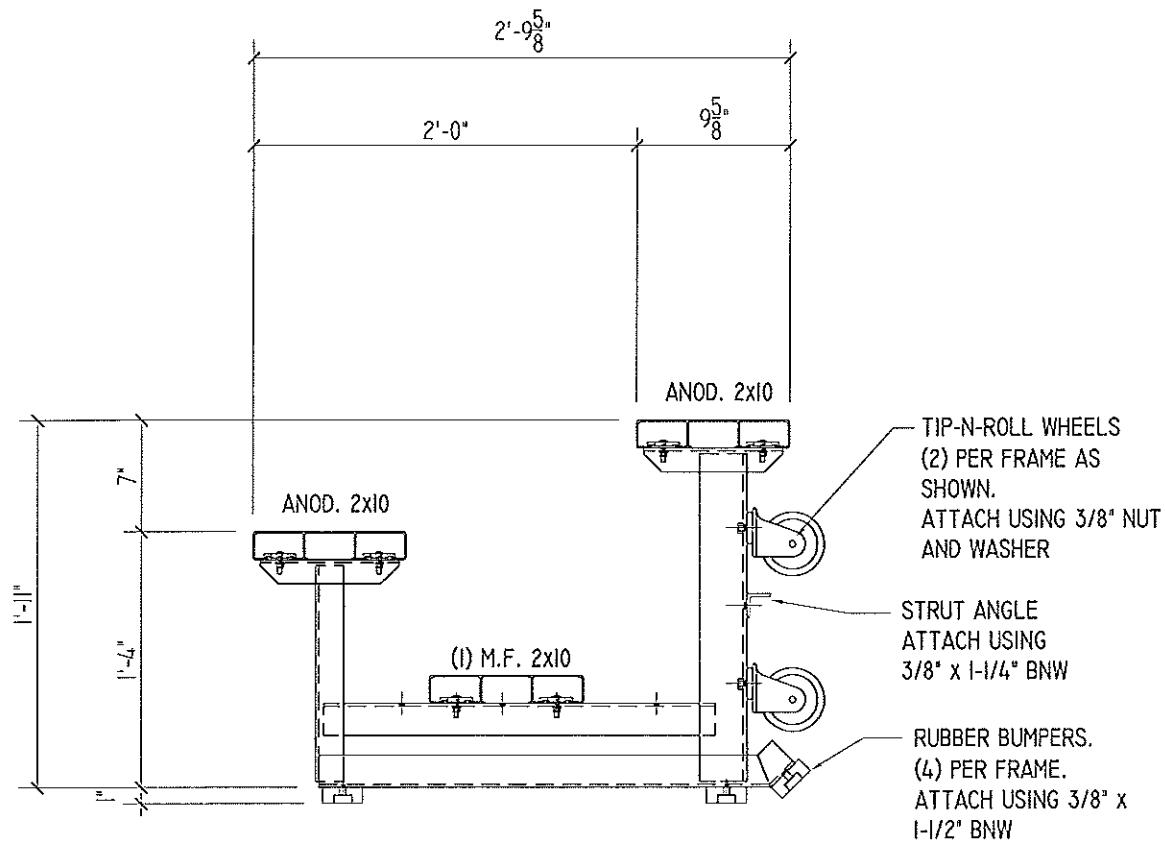

TYPICAL SECTION THRU BLEACHER

SCALE: 1"=1'-0"

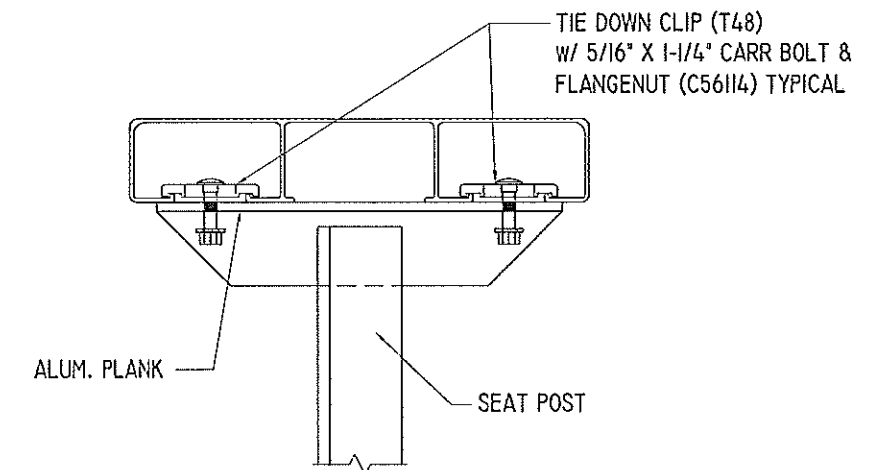

SEAT PLANK INSTALLATION

SCALE: 3" = 1'-0"