

SEATING PLAN

SCALE: 3/8"=1'-0"

NET SEATS = 42

LOCAL CODES AND SPECIFICATIONS WILL VARY FROM REGION TO REGION AND WILL ALSO CHANGE OVER TIME. IT IS THE BUYER'S RESPONSIBILITY TO CHECK LOCAL CODES FOR COMPLIANCE.

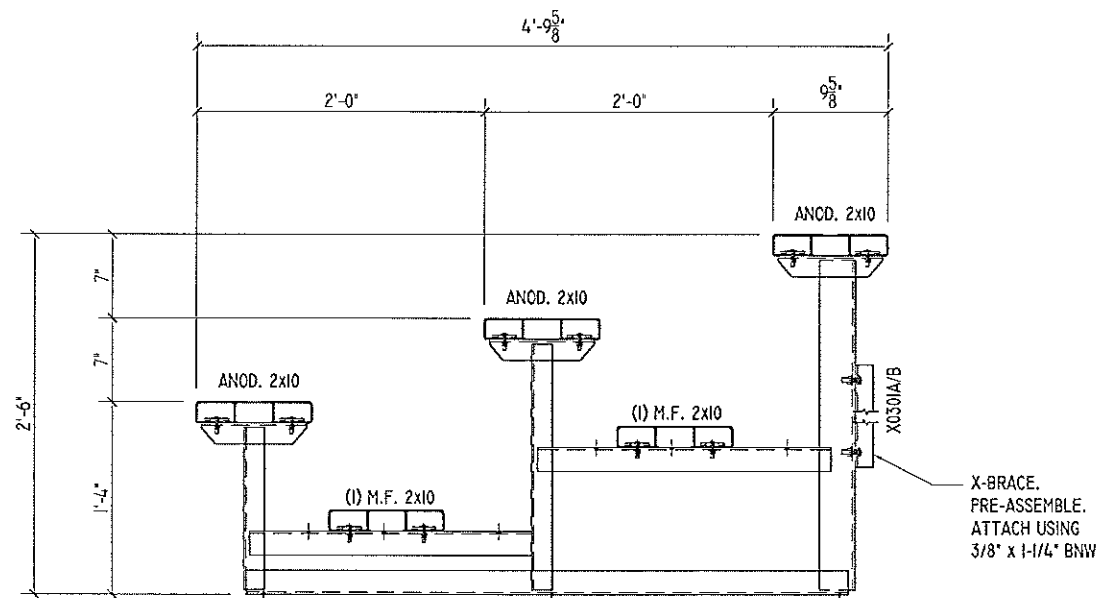

TYPICAL SECTION THRU BLEACHER

SCALE: 1"=1'-0"

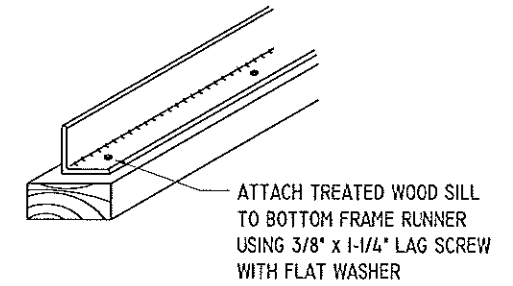

OPTIONAL MUD SILL ATTACHMENT

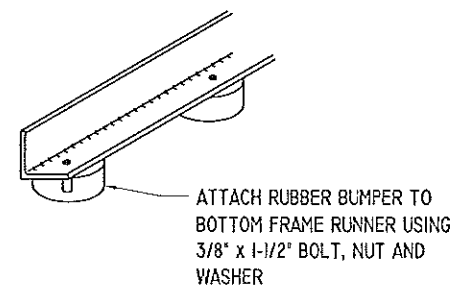

OPTIONAL RUBBER BUMPER ATTACHMENT

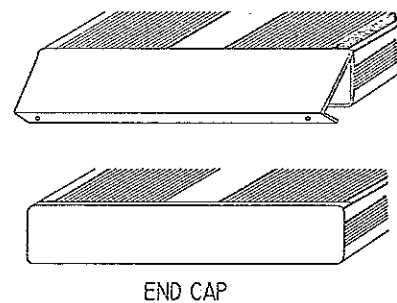

END CAP

1. LOCATE THE CHANNEL END CAP AS SHOWN, WITH THE WIDER FLANGE ON BOTTOM.
2. TAP THE CHANNEL INTO PLACE WITH A RUBBER Mallet OR SOFT WOOD.
3. DRILL (2) No.8 x 3/4" TEK SCREWS THRU END CAP AND BOTTOM FLANGE OF PLANK
4. ENDCAPS WITH STICKERS ARE TO GO AT ENDS OF SEAT PLANKS, PLAIN ENDCAPS GO ON ALL OTHER BOARDS.

ENDCAP INSTALLATION DETAIL

SCALE: 3" = 1'-0"

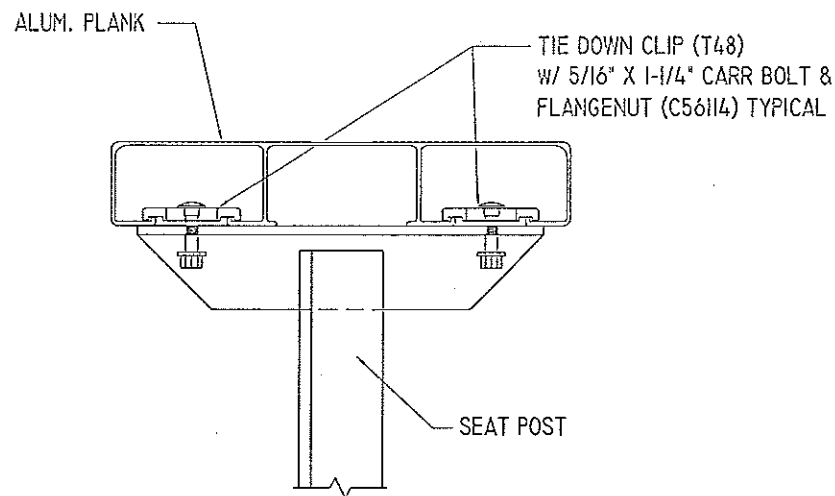

SEAT PLANK INSTALLATION

SCALE: 3" = 1'-0"

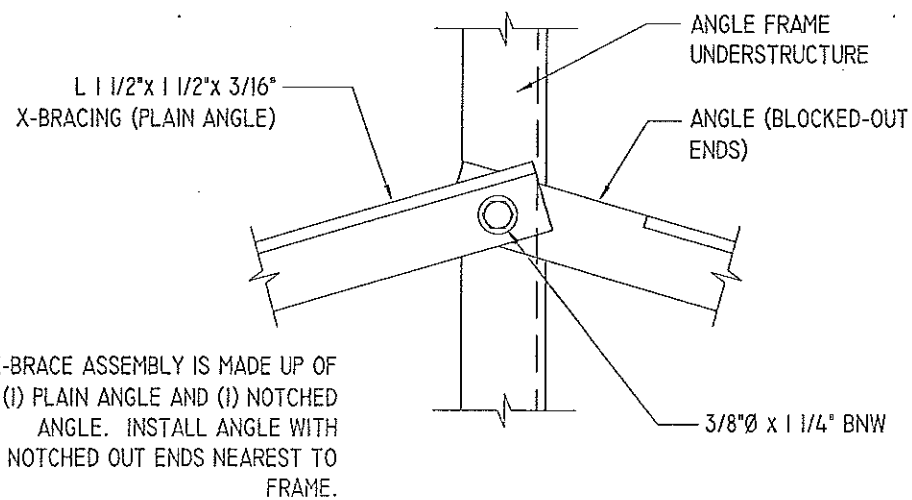

X-BRACE ASSEMBLY IS MADE UP OF (1) PLAIN ANGLE AND (1) NOTCHED ANGLE. INSTALL ANGLE WITH NOTCHED OUT ENDS NEAREST TO FRAME.

TYPICAL X-BRACE TO FRAME CONN.

SCALE: 3" = 1'-0"

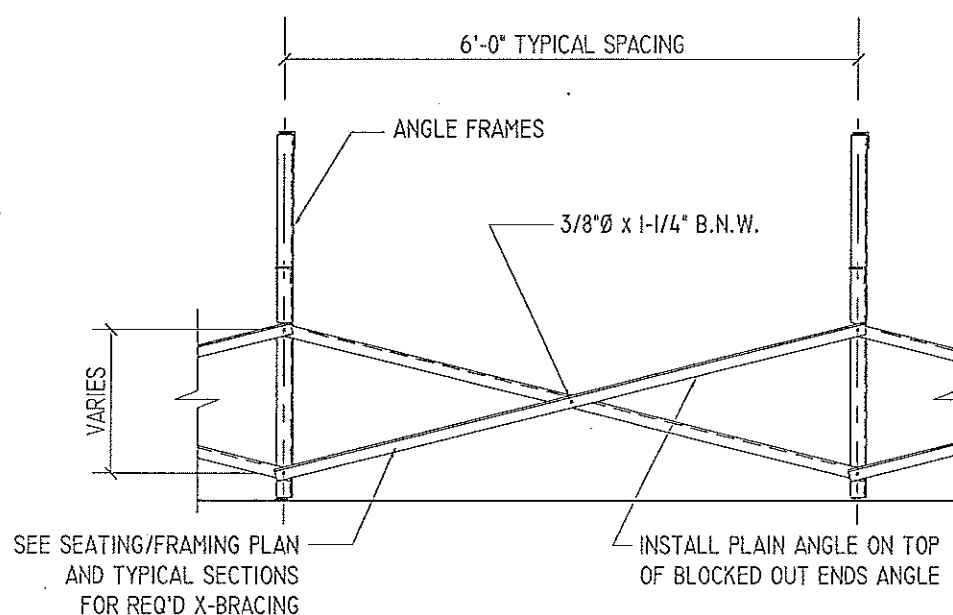

SEE SEATING/FRAMING PLAN AND TYPICAL SECTIONS FOR REQ'D X-BRACING

TYPICAL BRACING LAYOUT

SCALE: 1/2" = 1'-0"

PRE-ASSEMBLE X-BRACE SETS. EACH SET CONSISTS OF A 'PART A (UN-NOTCHED)' AND A 'PART B (NOTCHED)'. PLACE THE PIECES TOGETHER AT THE FLAT SIDES AND CONNECT USING A 3/8" x 1-1/4" B.N.W.

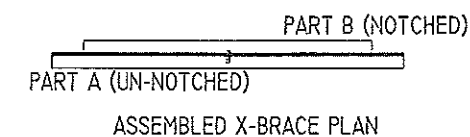

ASSEMBLED X-BRACE PLAN